



CONCRETE PRODUCTS GROUP

INNOVATIVE CONCRETE MASONRY SYSTEMS

SPEC-THERMAL[®] Detailing Guide 2020 Edition

www.concreteproductsgroup.com

800-789-0872

HI-R
HI-R-H
HI-R Half High
HI-R-H Half High

Table of Contents

[INTRODUCTION](#)

[KORFIL HI-R, HI-R-H AND SPEC-BRIK HI-R – PRODUCT FEATURES](#)

[HI-R](#)

[HI-R HALF HIGH/SPEC-BRIK HI-R](#)

[HI-R-H](#)

[HI-R-H HALF HIGH/SPEC-BRIK HI-R-H](#)

[Specialty Units](#)

[CONSTRUCTION NOTES](#)

[CONSTRUCTION DETAILS](#)

[Foundation and Base of Wall Details- Navigation Page](#)

[Figure 1](#)

[Figure 2](#)

[Figure 3](#)

[Figure 4](#)

[Figure 5](#)

[Figure 6 HI-R-H Basement Wall](#)

[Figure 7 HI-R-H Stem Wall](#)

[Movement Joints and Joint Reinforcement](#)

[Figure 8 Michigan Style Joint HI-R Section](#)

[Figure 9 Michigan Style Joint HI-R Plan](#)

[Figure 10 Rapid Control Joint](#)

[Figure 11 HI-R-H or HI-R-H Half High Jamb/Corner Unit](#)

[Figure 12 Horizontal Joint Reinforcement](#)

[Window Sills Navigation Page](#)

[Figure 13. HI-R Window Sill](#)

[Figure 14. HI-R Half High Window Sill](#)

[Figure 15. HI-R-H Window Sill](#)

[Figure 16. HI-R-H Half High Window Sill](#)

[Window Jamb Navigation Page](#)

[Figure 17. HI-R Window Jamb](#)

[Figure 18. HI-R Half High Window Jamb](#)

[Figure 19. HI-R-H Window Jamb](#)

[Figure 20. HI-R-H or HI-R-H Half High Jamb Unit](#)

[Lintels Navigation Page](#)

[Figure 21. HI-R Lintel](#)

[Figure 22 HI-R Half High Lintel](#)

[Figure 23. HI-R-H Lintel](#)

[Figure 24 HI-R-H Half High Lintel](#)

[Figure 25 HI-R Insulated Lintel](#)

[HI-R-H Corners Navigation Page](#)

[Figure 26. 10" HI-R-H Corner. Exterior Soap](#)

[Figure 27. 10" HI-R-H Corner. L-Shape Veneer – course 1](#)

[Figure 28. 10" HI-R-H Corner. L-Shape Veneer – course 2](#)

[Figure 29. 10" HI-R-H Corner. L-Shape Veneer EPS/XPS – course 1](#)

[Figure 30. 10" HI-R-H Corner. L-Shape Veneer EPS/XPS – course 2](#)

[Figure 31. 12" HI-R-H Corner – Exterior Soap](#)

[Figure 32. 12" HI-R-H Corner. L-Shape Veneer – course 1](#)

[Figure 33. 12" HI-R-H Corner – L Shaped Veneer – course 2](#)

[Figure 34. 12" HI-R-H Corner. L-Shape Veneer – course 1](#)

[Figure 35. 12" HI-R-H Corner – L Shaped Veneer EPS/XPS – course 2](#)

[Figure 36 HI-R-H/HI-R-H Half High Corner/Jamb Unit](#)

[Wall Intersections Navigation Page](#)

[Figure 37. HI-R T intersection \(Non-Structural\) Option 1](#)

[Figure 38. HI-R T intersection \(Non-Structural\) Option 2](#)

[Figure 39. HI-R T intersection \(Structural\) Option 1](#)

[Figure 40. HI-R T intersection \(Structural\) Option 2](#)

[Planks Navigation Page](#)

[Figure 41. HI-R Plank Bearing Wall Fully Grouted](#)

[Figure 42. HI-R Plank Bearing Wall Partially Grouted](#)

[Figure 43. HI-R Plank Non-Bearing Wall Partially Grouted](#)

[Figure 44. HI-R Half High Plank Bearing Wall Fully Grouted](#)

[Figure 45 HI-R Half High Plank Bearing Wall Partially Grouted](#)

[Figure 46 HI-R Half High Plank Bearing Wall Partially Grouted](#)

[Figure 47 HI-R-H Plank Bearing Wall Fully Grouted](#)

[Figure 48 HI-R-H Plank Non-Bearing Wall Fully Grouted](#)

[Figure 49 HI-R-H Half High Plank Bearing Wall Fully Grouted](#)

[Figure 50 HI-R-H Half High Plank Non-Bearing Wall Fully Grouted](#)

[Roof Joist/Parapet Navigation Page](#)

[Figure 51. HI-R Roof Joist/Parapet Non-Bearing Wall Partially Grouted](#)

[Figure 52. HI-R Roof Joist/Parapet Bearing Wall Partially Grouted](#)

[Figure 53. HI-R Roof Joist/Parapet Non-Bearing Wall Fully Grouted](#)

[Figure 54. HI-R Roof Joist/Parapet Bearing Wall Fully Grouted](#)

[Figure 55 HI-R Half High Roof Joist/Parapet Non-Bearing Wall Partially Grouted](#)

[Figure 56 HI-R Half High Roof Joist/Parapet Bearing Wall Partially Grouted](#)

[Figure 57. HI-R Half High Roof Joist/Parapet Non-Bearing Wall Fully Grouted](#)

[Figure 58. HI-R Half High Roof Joist/Parapet Bearing Wall Fully Grouted](#)

[Figure 59 HI-R-H Roof Joist/Parapet Bearing Wall Fully Grouted](#)

[Figure 60 HI-R-H Roof Joist/Parapet Non-Bearing Wall Fully Grouted](#)

[Figure 61 HI-R-H Half High Roof Joist/Parapet Bearing Wall Fully Grouted](#)

[Figure 62 HI-R-H Half High Roof Joist/Parapet Non-Bearing Wall Fully Grouted](#)

[CODES AND STANDARDS REFERENCES](#)

[MEMBER LOCATION MAP](#)

Introduction

This manual focuses on how to detail wall systems using the Spec-Thermal family of pre-insulated masonry products from the Concrete Products Group. Pre-insulated concrete masonry is a masonry wall system where insulation is factory installed in the concrete masonry units so that it is in place prior to the placement of reinforcement and grout to provide integral insulation in the finished wall assembly. The products in Spec-Thermal family include the Korfil HI-R and HI-R-H pre-insulated masonry wall systems. The Korfil HI-R products are also offered in half high versions (HI-R Half High and HI-R-H Half High) that when combined with our Spec-Brik blended colors to provide brick aesthetics are called Spec-Brik HI-R and Spec-Brik HI-R-H.

Pre-insulated masonry units have these system components:

- Concrete Masonry Units specially designed to minimize thermal bridging by reducing the cross sectional area of the web(s) that cross from the exterior to the exterior of the unit.
- Insulating expandable polystyrene inserts placed inside the unit, simultaneously reducing thermal bridging. They are typically installed at the factory. The inserts constitute Code-defined integral insulation.
- The CMU, Mortar, Reinforcement and Grout act structurally in composite action (Moment of Inertia, Section Modulus, etc.) as based upon Structural Engineer's criteria for loads resistance.

The Spec-Thermal products allow the construction of insulated wall assemblies where one or both of the interior or exterior wall surfaces can offer the durability and aesthetics of masonry exposure. The systems are designed so that the insulation remains in place even where reinforcement and grout are placed so that there is no compromise to the walls thermal performance. Behind the unit's face shells and mortar (both of which have Integral Water Repellent along with a breathable penetrating sealant are the interlocking insulation inserts. The inserts also assist in resisting wind-driven rain. Where partially grouted, occasional drainage continues through the flashing and weep system.

There are numerous benefits to these systems:

- Pre-insulated masonry vastly outperforms conventional masonry's thermal performance, offering the ability to meet or exceed Energy Code requirements with single wythe walls.
- Improved dew point profile thereby assisting condensate control. Further, masonry is not only tolerant to condensate, it is also not a food for mold and does not corrode or rot.
- Improves outdoor-indoor sound transmission class.
- Insect and varmint resistance. No chemical treatments required.
- CMU mass walls offer strong Fire-resistance ratings

Pre-Insulated masonry not only meets extreme design parameters, it also offers the flexibility to design projects that balance cost concerns against typical project requirements including time of construction, Code and contractual requirements, and aesthetics.

A Note About Masonry Flashing

Properly flashing masonry walls is a key strategy for partially grouted walls to ensure that wall assemblies resist moisture penetration. There are many types of flashing available today, each with its own characteristics. This Guide assumes design and construction compliance with applicable Building Codes as amended and adopted. Further, and when applicable, the Guide assumes the use of flashing with partially grouted walls (whether generic, specialized or proprietary, partial or completely through-wall, etc). Yet it also reflects the choices and options available to the Design Community rather than insisting on any particular type of primary and secondary moisture control strategy (belt-and-suspenders approach) regarding a particular project.

For instance there are circumstances where a member of the Design Community with permission of the Certified Building Official (via Plan Review, etc.) may choose primary and secondary methods of moisture control other than the inclusion of flashing. As an example when heavy reinforcement and full grouting is required, generic flashing may be considered impractical or onerous within a multi- or single-wythe masonry wall.

Similar alternate strategies may be chosen for uniform masonry barrier wall elements. Solid grouted composite (completely grouted – including collar joints – multi-wythe masonry; see Masonry Code TMS 402 definition), solid grouted non-composite multi-wythe masonry walls, and solid grouted single-wythe walls are all considered barrier walls.

Codes and Standards References

There are numerous provisions of Code that are applicable to the construction of masonry walls, many of which are found in sections that may not intuitively seem to be related to masonry. Similarly, there are a variety of applicable standards that may relate to other building components or general areas of concern such as energy conservation. We have included a comprehensive set of references to applicable Codes and Standards for the construction of structures using masonry. These are based on Model Code provisions. As always, designers should look to the local Code requirements for guidance on particular projects.

Design Resource Center

The Concrete Products Group has a dedicated website to provide designers access to design tools, the Design Resource Center, which is a registration based site. The site includes a variety of resources including downloadable versions of the details in this manual in AutoCAD® or Revit formats, our Masonry Designer color catalog and Revit Plug-in, design and construction notes and videos, and other helpful resources. We also have provided a guide specification on the site that is available for download. You can request free registration to the site at this link:

[Design Resource Center Access Page](#)



What is High Performance Concrete Masonry?

High Performance Concrete Masonry uses state of the industry best practices relating to the construction of concrete masonry and related building envelope components to produce a building envelope that efficiently meets or exceeds project requirements in a cost-effective manner. While these techniques comply with Code, they also in many instances include additional recommendations that can deliver superior results when it comes to moisture protection, energy efficiency, or other key issues.

Comprehensive Construction Details

This Guide includes a set of Construction Details that offer high performance recommendations for how to detail a variety of common structural elements. Each detail is supported by typical notes. Designers should modify these details to suit the requirements of their design.

A small thumbnail image of a 'Table of Contents' page, showing a list of sections and their corresponding page numbers. The text is too small to read clearly, but the layout is typical of a document's table of contents.



Korfil HI-R
Korfil HI-R-H
Spec-Brik HI-R

Product Features

Pre-insulated Masonry

Pre-insulated masonry allows the construction of insulated wall assemblies where one or both of the interior or exterior wall surfaces can offer the durability and aesthetics of masonry exposure. The systems are designed so that the insulation remains in place even where reinforcement and grout are placed so that there is no compromise to the wall's thermal performance. The International Energy Conservation Code does not require either an additional exterior wall envelope or a vapor barrier for these moisture tolerant load bearing systems.

For moisture control, these walls use a "belt and suspenders" approach. Multiple measures resist moisture penetration. The Spec Thermal units and the mortar contain integral water repellent. A Post-Applied clear breathable water repellent sealer is applied to the exterior of the wall system. The interlocking insulation inserts provide additional resistance to wind driven rain. When partially grouted, drainage is provided in the cores to the flashing and weep systems. When fully grouted, no flashing or weeps are necessary except adjacent to certain openings in the wall.

The wall systems presented in this manual can be fully grouted or partially grouted (the HI-R-H system is available only with full grout). Typically the two approaches will be similar in cost, and fully grouted structures may offer a simpler approach to moisture control. When fully grouted, the system is deemed to comply with the International Energy Conservation Code's air barrier requirements. Fully grouted structures also do not require flashing, weeps, drainage tubes or vents except possibly adjacent to certain wall openings.

When partially grouted, several Code-based methods, including application of block fillers, paints or sealants can be employed to provide an air barrier.

Both approaches will yield excellent results when properly detailed.



Many Aesthetic Options

Table of Contents	
Introduction	1
Chapter 1: Pre-Insulated Masonry	2
Chapter 2: Insulation	3
Chapter 3: Air Barrier	4
Chapter 4: Vapor Barrier	5
Chapter 5: Water Barrier	6
Chapter 6: Acoustic Treatment	7
Chapter 7: Fire Protection	8
Chapter 8: Security	9
Chapter 9: Sustainability	10
Chapter 10: Conclusion	11

Korfil HI-R®

Korfil HI-R® is a proven solution for the construction of energy efficient structures with a track record of several decades of successful performance. The insulation inserts and reduced web profiles provide HI-R with significant advantages over conventional masonry, while offering the durability, simplicity and aesthetic appeal of double exposed masonry. Korfil HI-R provides designers with the flexibility to meet demanding energy Codes with proven performance.

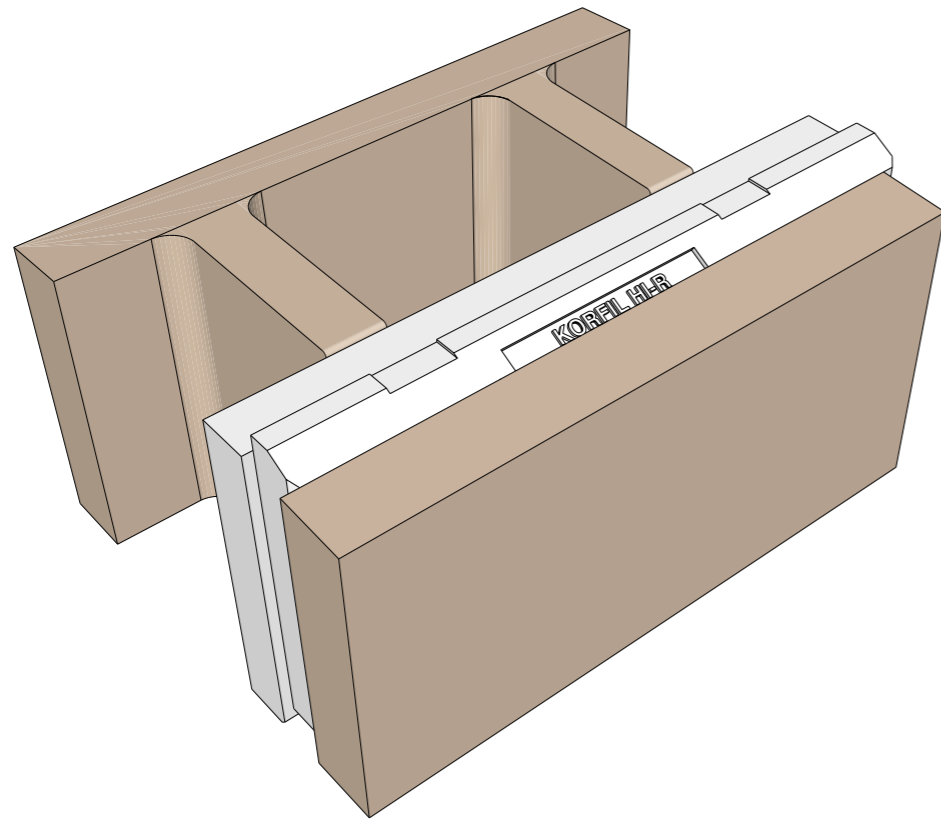

12x8x16 Korfil HI-R Unit

Table of Contents	
Introduction	1
Key Features	2
Energy Efficiency	3
Construction Efficiency	4
Compatibility and Flexibility	5
Moisture Penetration Resistance	6
Air Barrier Requirements	7
Aesthetic Choices	8
Technical Specifications	9
Installation	10
Quality Assurance	11
Warranty	12
Contact Us	13

Key Features

Energy Efficiency. The HI-R System offers thermal performance that gives designers the flexibility to meet Code requirements with a masonry wall system that uses integral insulation.

Construction Efficiency. The HI-R wall system is an efficient single wythe wall system where the insulation and interior and exterior wall finishes are all constructed in a single construction step. HI-R is an excellent choice for partially grouted walls so that materials usage efficiency is optimized.

Compatibility and Flexibility. The HI-R wall system is fully compatible with standard masonry fittings and interfaces seamlessly with other building components giving the designer unlimited detailing flexibility.

Moisture Penetration Resistance. Multiple measures resist moisture penetration. SPEC-BRIK HI-R units and the mortar contain integral water repellent. A Post-Applied clear breathable water repellent sealer is applied to the wall system. The interlocking insulation inserts provide increased resistance to wind driven rain. When partially grouted, drainage is provided in the cores to the flashing and weep systems. When fully grouted, no flashing or weeps are necessary except adjacent to certain openings in the wall.

Air Barrier Requirements. When partially grouted, several Code-based methods, including application of block fillers, paints or sealants can be employed for this system. When fully grouted, the system is deemed to comply with the International Energy Conservation Code's air barrier requirements. Fully grouted structures also do not require flashing, weeps, drainage tubes or vents except possibly adjacent to certain wall openings.

Aesthetic Choices. HI-R units are available in the full range of masonry finishes and colors.



HI-R® Half High (Spec-Brik HI-R)

The **SPEC-BRIK HI-R Wall System** adds SPEC-BRIK color blends to a half high H-R unit configuration with individually molded insulation inserts. This allows the construction of walls that offer the look of brick and provide superior thermal performance to assist in meeting prevailing Codes and Standards. The **SPEC-BRIK HI-R** Masonry Unit has been designed to provide reduced thermal bridging. The system gives the designer choices for a wall system capable of achieving higher thermal R-values than conventional masonry and Code compliant designs for load resistance purposes. SPEC-BRIK HI-R units may be used in both fully and partially grouted wall assemblies with no need to remove the insulation inserts so thermal performance is uncompromised.

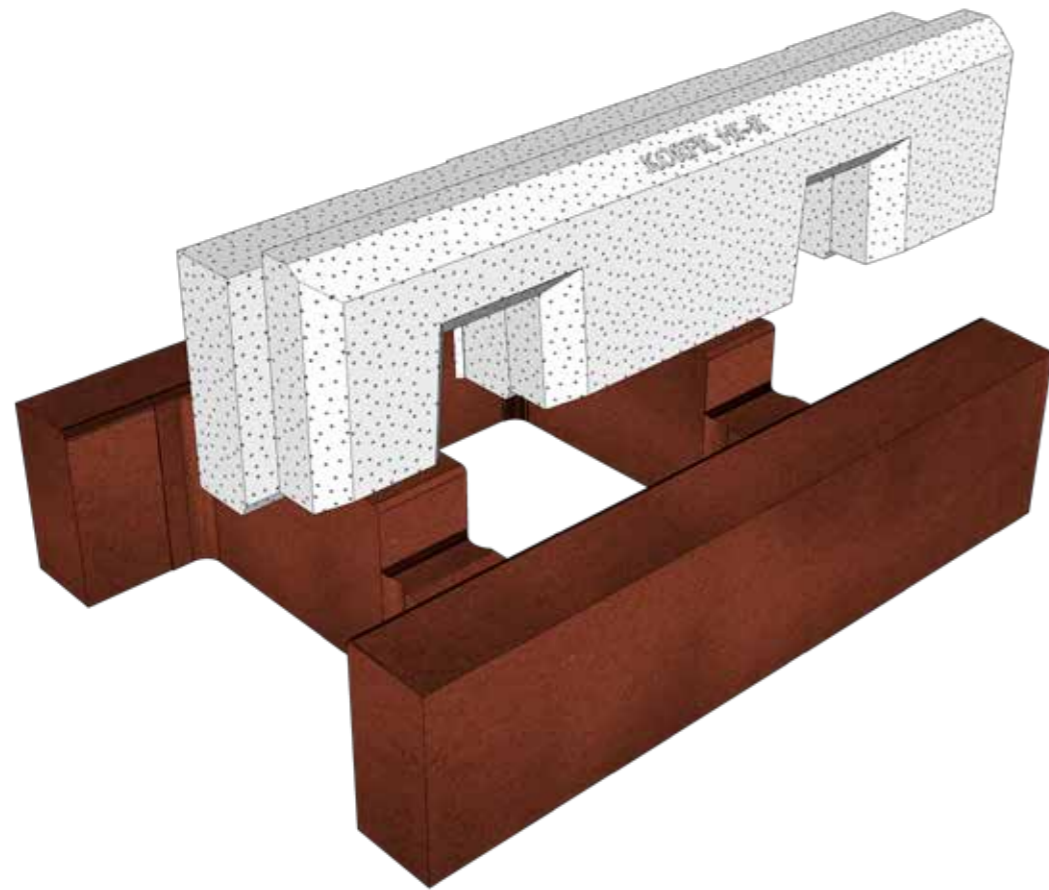

Spec-Brik® HI-R™

Table of Contents	
Introduction	1
Key Features	2
Enhanced Thermal Protection	3
Beauty	4
Durability and Resilience	5
Ease of Installation	6
Consistent Insulation	7
Moisture Control	8
Table of Contents	9

Key Features

Enhanced Thermal Protection. SPEC-BRIK HI-R units provide the same level of thermal performance as full height Korfil HI-R units in terms of thermal mass and insulation, providing a considerable advantage over conventional masonry and other wall systems.

Beauty. SPEC-BRIK HI-R units are offered in dimensions and blended colors that provide the look of brick at affordable costs.

Durability and Resilience. SPEC-BRIK HI-R offers the durability of double exposed masonry to protect the insulation inserts and provide a long-lasting and resilient building envelope.

Ease of Installation. SPEC-BRIK HI-R is installed using standard methods. The units come pre-assembled with the insulation inserts. Construction of standard masonry details is straightforward. Units may be saw cut to reduce web height for use as knock out bond beam units.

Consistent Insulation. SPEC-BRIK HI-R units can be partially or fully grouted without removing the insulation inserts, so that thermal performance is consistent through the wall structure.

Moisture Control. Multiple measures resist moisture penetration. SPEC-BRIK HI-R units and the mortar contain integral water repellent. A Post-Applied clear breathable water repellent sealer is applied to the wall system. The interlocking insulation inserts provide increased resistance to wind driven rain. When partially grouted, drainage is provided in the cores to the flashing and weep systems. When fully grouted, no flashing or weeps are necessary except adjacent to certain openings in the wall.



Korfil HI-R-H®

The HI-R-H Wall System is a high performance pre-insulated wall system intended for the most demanding climates and structural needs. The HI-R-H Masonry Unit has been designed to provide reduced thermal bridging even compared to other HI-R designs by having only a single web, and a two thicker insulation insert options. The block and the insulation are combined at the block manufacturing plant prior to delivery to the job site. The system gives the designer choices for a wall system capable of achieving higher thermal R-values than conventional masonry and Code compliant designs for load resistance purposes.

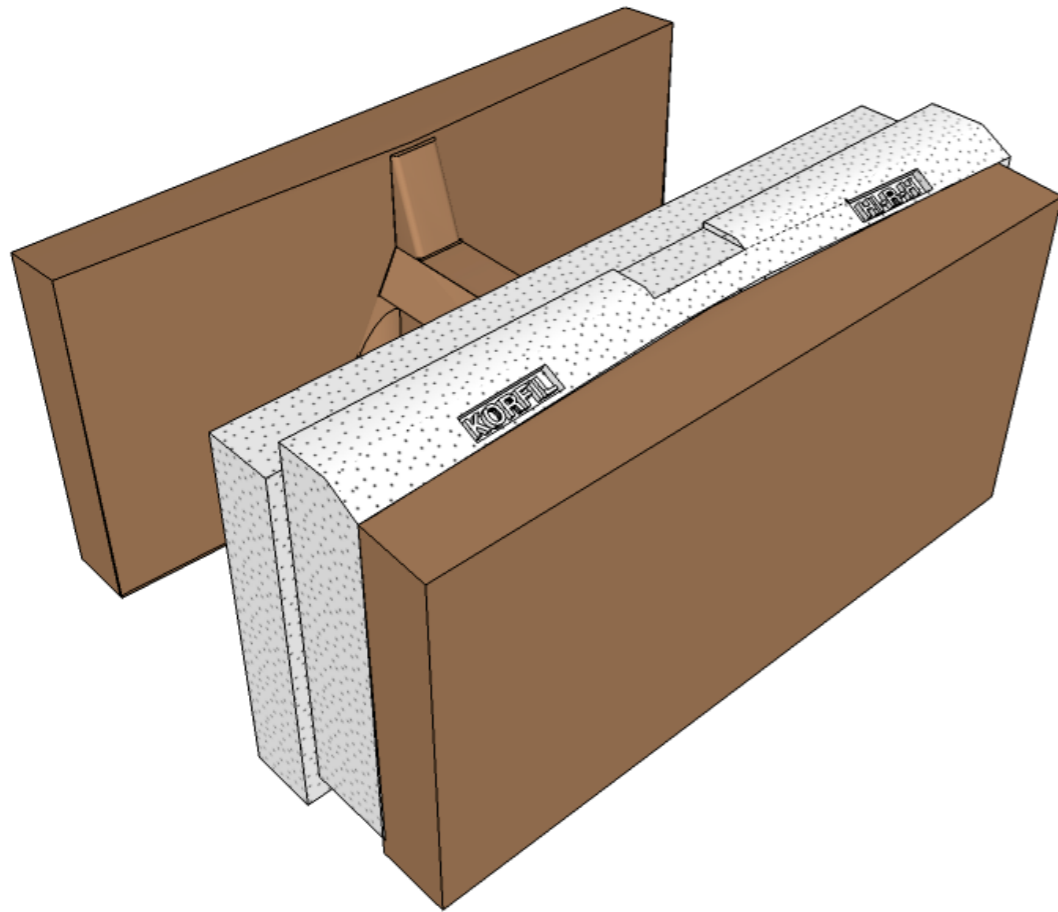

**12×8×16 Korfil HI-R-H Unit
Fully Grouted Wall Assemblies**



Key Features

Enhanced Thermal Protection. The single web and thicker insulation insert in the HI-R-H units minimizes thermal bridging to provide the highest level of thermal performance in the Korfil HI-R product family, making HI-R-H wall systems suitable for all climate zones.

Aesthetic Options. HI-R-H units are available in a wide variety of finishes and colors, including our Spec-Brik color blends, allowing the designer unlimited choices.

Structural Performance. The HI-R-H wall system is designed for use in fully grouted wall assemblies and is a great choice for use in regions where highly reinforced walls are necessary to meet structural requirements. Its double open-ended "H" configuration eases unit installation even with tightly spaced vertical reinforcement since the units may be placed without the need to lift them over the top of the vertical reinforcement steel.

Ease of Installation. HI-R-H units are installed using standard methods. The units come pre-assembled with the insulation inserts. Construction of standard masonry details is straightforward since the units are compatible with standard masonry fittings, which may also be pre-insulated with insulation inserts. Units are suitable for construction of bond beam courses without the need for special units, modification of the masonry unit, or removal of the insulation insert.

Uncompromised Insulation. HI-R-H units are designed to be fully grouted without removing the insulation inserts, so that thermal performance is uncompromised through the wall structure.



Korfil HI-R-H® Half High (Spec-Brik HI-R-H)

HI-R-H Half High is a single web pre-insulated masonry unit with 4" x 16" face dimension that is suitable for fully grouted walls intended for the most demanding climates and structural needs. When made with Spec-Brik colors, the product is called Spec-Brik HI-R-H

HI-R-H Half High has the thickest (4") inserts in the HI-R-H product line, and offers the highest level of thermal performance.

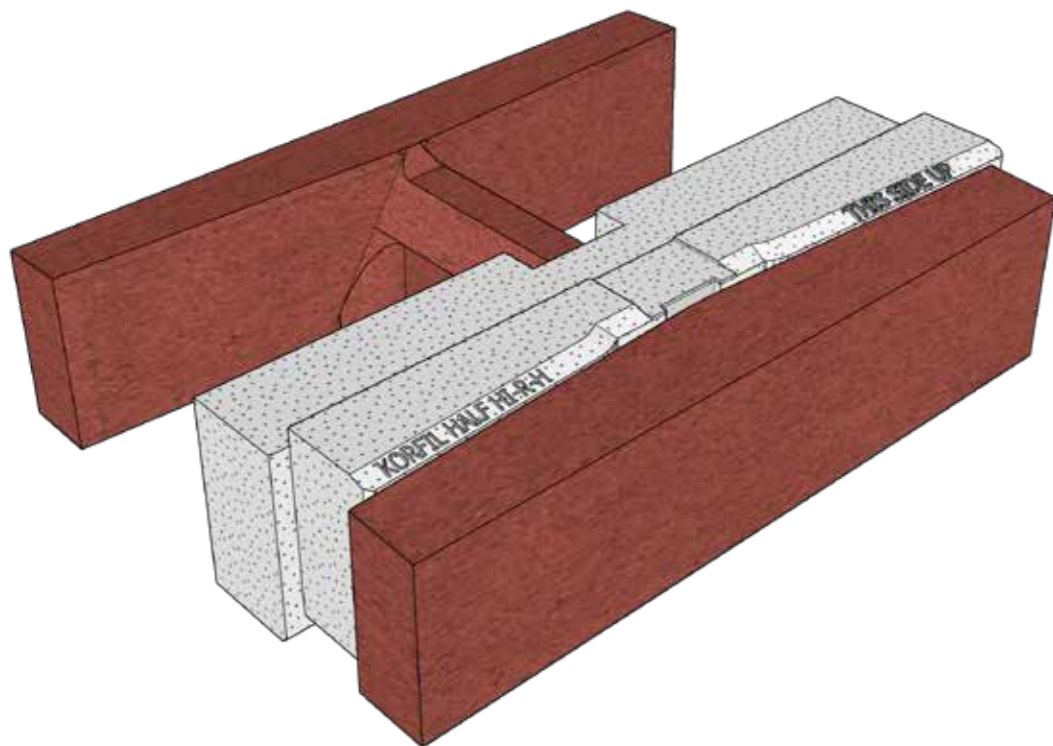

**12x4x16 Korfil HI-R-H Half High Unit
Fully Grouted Wall Assemblies**

Key Features

Aesthetics. Double exposed masonry with brick aesthetics -durable architectural finishes inside and out.

Thermal Performance. Two-part 4" nominal offset interlocking insulation insert – thickest insert currently available. Interlocking insulation covers all mortar joints. Insert uses higher density EPS to enhance thermal performance. Single partial height web for reduced thermal bridging. Thermal mass exposed to the interior, conditioned space for optimal thermal performance Fully Grouted Wall System.

Fully Grouted Wall Benefits. Barrier wall performance resists moisture penetration/condensation issues with use of integral water repellent in block and mortar and post-applied sealant. Fire resistance: Four hour fire rating is typical. No additional air barrier or vapor retarder is required with fully grouted masonry walls (assumes use of integral water repellent in unit and mortar). Great choice for structures designed to be resilient against natural hazards and for demanding applications requiring extensive reinforcement.

Construction Efficiency. Shape eases placement even with tight reinforcement spacing. No modification to stretcher unit required for bond beam construction. Utilities (plumbing and electrical) readily fit in unit cores and horizontal voids. Single trade installs interior and exterior finishes, structure and insulation in one step- no separate construction of framing, exterior veneer and insulation is required.



Durable Masonry Beauty – Inside and Out

Specialty Units

HI-R-H and HI-R-H Half High Jamb/Corner Units

Specialty Jamb and Corner Units are available for both full high and half high HI-R-H walls. When calculating the thermal values for the wall as a whole, the values associated with movement joints, jamps, corners, lintels and sills should be taken into account as part of the overall wall assembly. S

Limited to Regional Availability: check with your local manufacturer prior to specification.

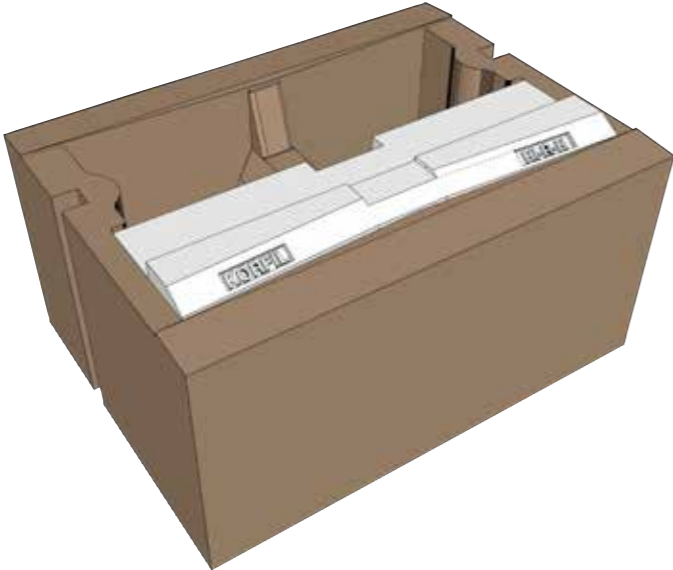

12x8x16 HI-R-H Jamb/Corner Unit

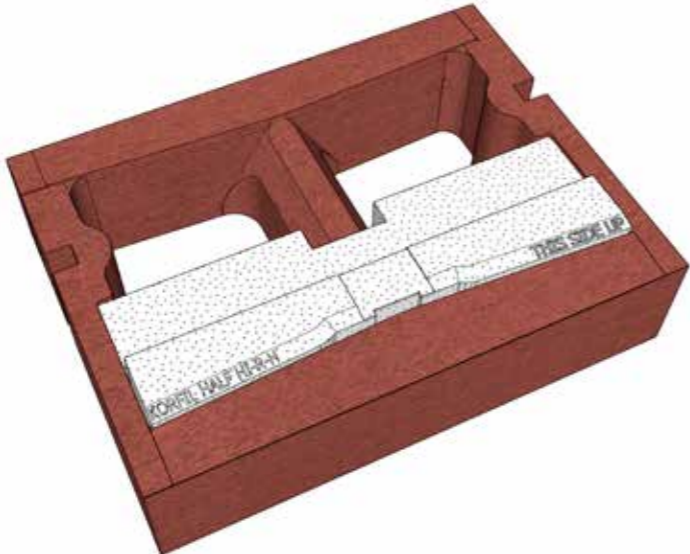

12x4x16 HI-R-H Half High Jamb/Corner Unit

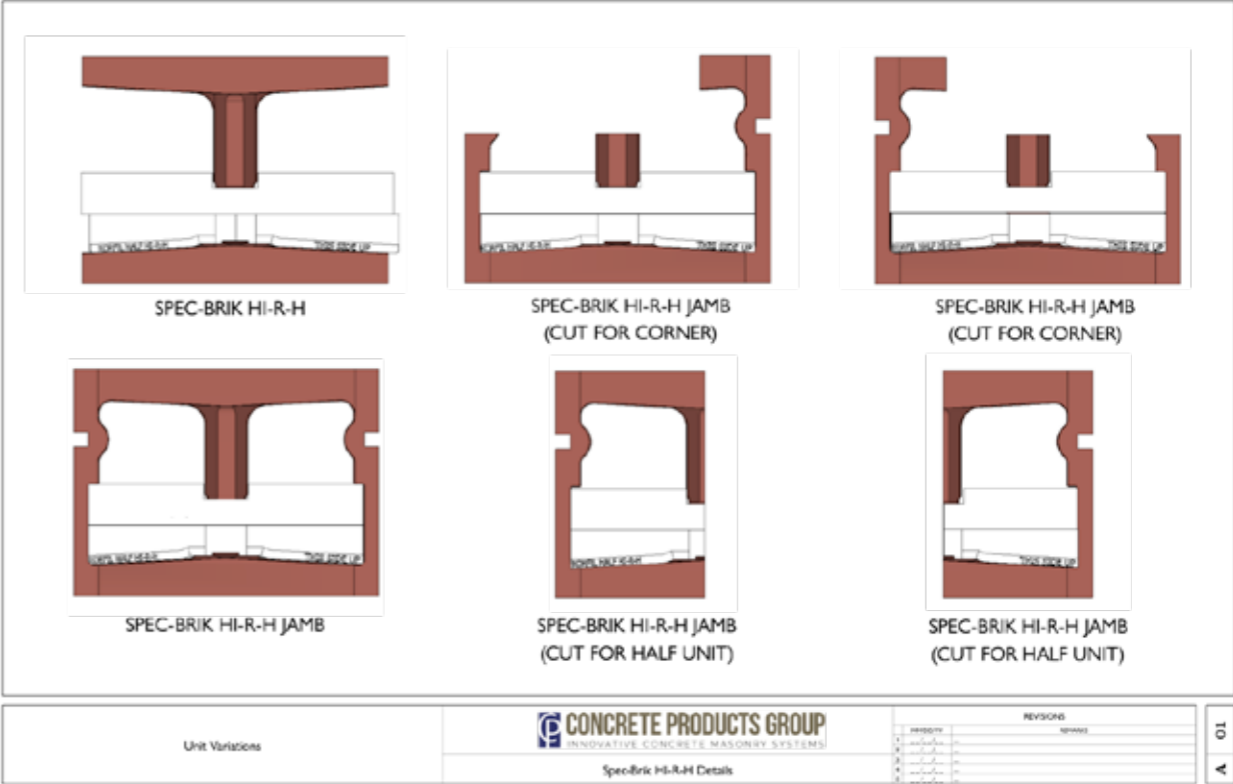

Configurations for corners, ends and jamps

Specialty Units

HI-R Closed Bottom Lintel Unit

This is a closed bottom, architectural lintel masonry unit that is insulated with an EPS insert to provide superior thermal performance to uninsulated traditional lintel designs. See Table X for thermal values that should be entered for the portions of the walls where this product is used. **Regional availability only: please check with your local CPG producer for local availability prior to specification.**

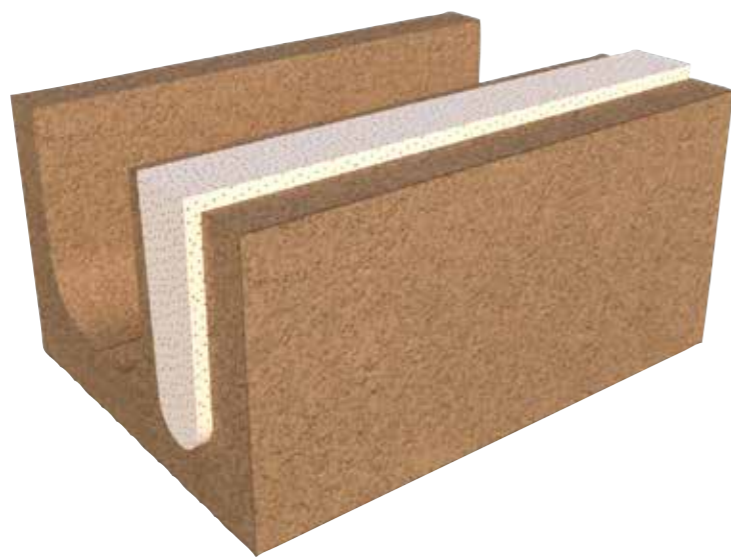

12x8x16 HI-R Lintel Unit

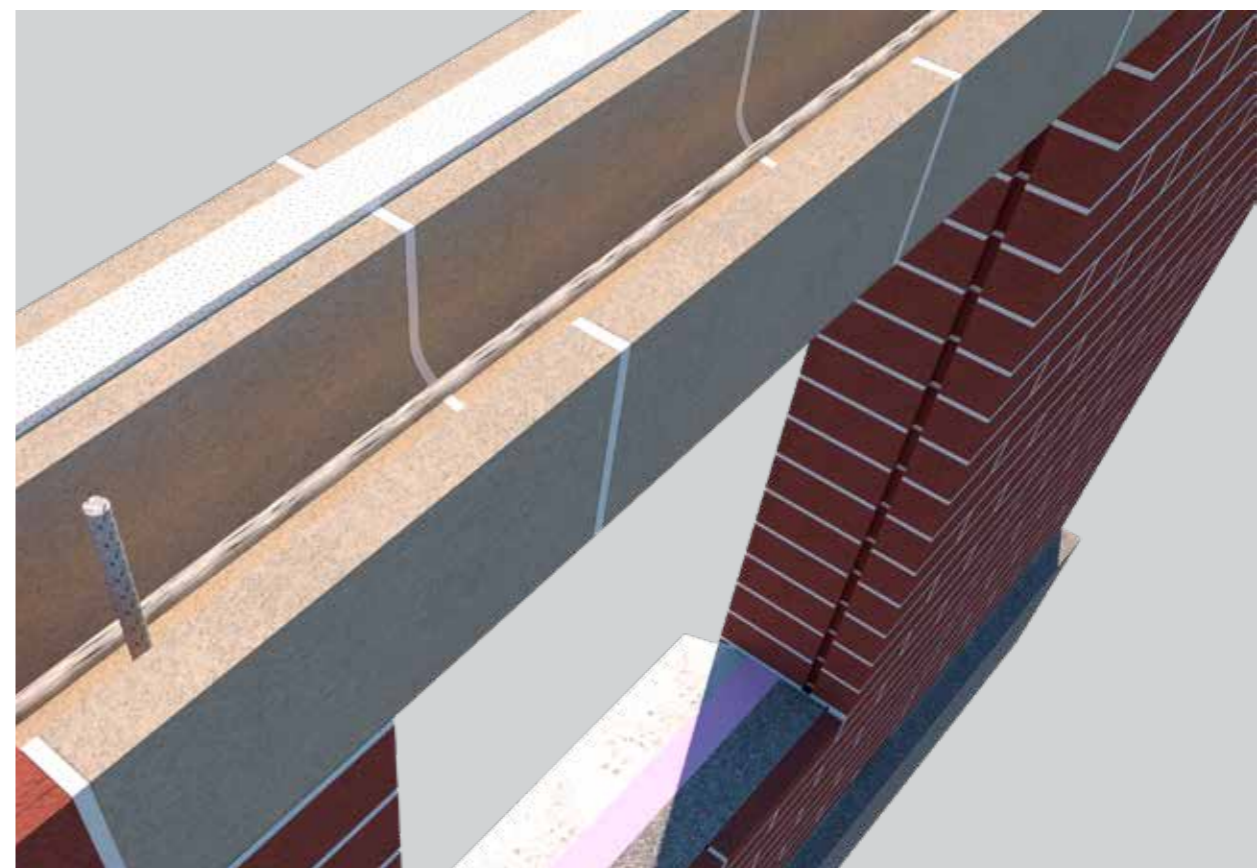

SPEC-BRIK HI-R/HI-R-H Colors

SPEC-BRIK HI-R/HI-R-H is available in 12 standard colors and custom colors are available by special order.

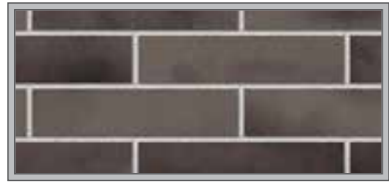

Basalt Blend



Chesapeake Blend



Delaware Blend



Flint Blend



Dixon Blend



Gardner Blend



Houston Blend

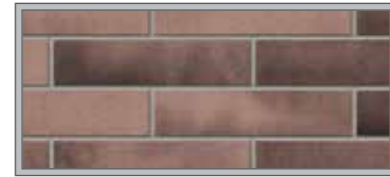

Jefferson City Blend

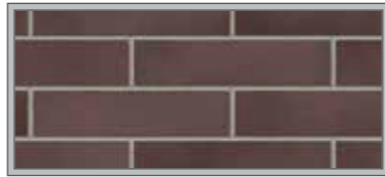

Panama City Blend

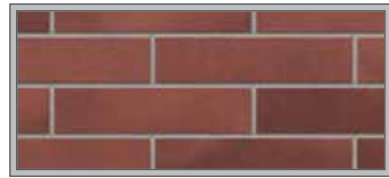

Philadelphia Blend



St. Cloud Blend

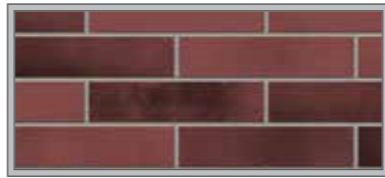

Stanton Blend

SPEC-BRIK® Colors

Other Accessory Items

Icon® insulation inserts are often used to insulate masonry fittings used with pre-insulated Korfil HI-R or HI-R-H units, for the construction of corners, jambs, wall ends or movement joints. Icon inserts are available from Concrete Block Insulating Systems, Inc.

Some of the details show the use of **Extruded Polystyrene** insulation cut to fit masonry fittings at corners, jambs, wall ends and movement joints. This is an alternative approach to provide insulation at these areas of the wall.

Flashing and Weep System. The details illustrate use of **Blockflash®** integrated pan flashing and weep system to provide drainage of moisture in the ungrouted cells of partially grouted walls. Blockflash® is a product available from Mortarnet, Inc.

We also recommend the use of a **clear, breathable post-applied sealant** along with the use of **integral water repellent** in both the mortar and block for single wythe masonry walls as part of a comprehensive strategy including proper detailing of the walls for best results to prevent of moisture penetration. The Aquaseal ME-12 sealant from Monopole, Inc. is one example of a suitable post-applied sealant.

Masonry Designer Software and Revit® Plug-in.

Masonry Designer Software is available at www.concreteproducts.com. This software allows designers to render wall sections with all CPG products and colors, including Spec-Brik, Spec-Block (grey CMU), and Spec-Split (Architectural Split face CMU). The program allows selection of both block and mortar colors, and allows experimentation with combinations of different colors and textures. A Revit® Plug-in is available from the same site to facilitate rendering models with the Spec-Brik colors.

Table of Contents	
Introduction	1
Product Overview	2
Colors	3
Accessories	4
Software	5
Revit Plug-in	6
Index	7



Construction Notes

A small thumbnail of the Table of Contents is located in the bottom right corner. It shows a list of page numbers and corresponding section titles, such as 'Introduction', 'About Us', 'Our Products', and 'Contact Us'. The text is too small to read clearly.

Korfil HI-R and HI-R-H Construction Notes

The following tips should be used for best results when building walls using Korfil® Hi-R and Hi-R H Wall Systems.

- 1. Unit and Mortar Dimensions.** The Hi-R and Hi-R H systems are designed to use a 3/8" mortar joint, head and bed. The units are 1/8" taller at the inside of the face shell (7-3/4") than at the face (7-5/8") so less mortar will be required for the bed joints than conventional CMU.
- 2. Install the Units "Right Side Up".** Korfil Hi-R/Hi-R-H Units are pre-insulated at the manufacturer and will arrive at the job site with the insulation in place. Unlike standard CMU, these units are not inverted for installation. When the units are correctly oriented, the insert will rest on top of the webs as shown below.

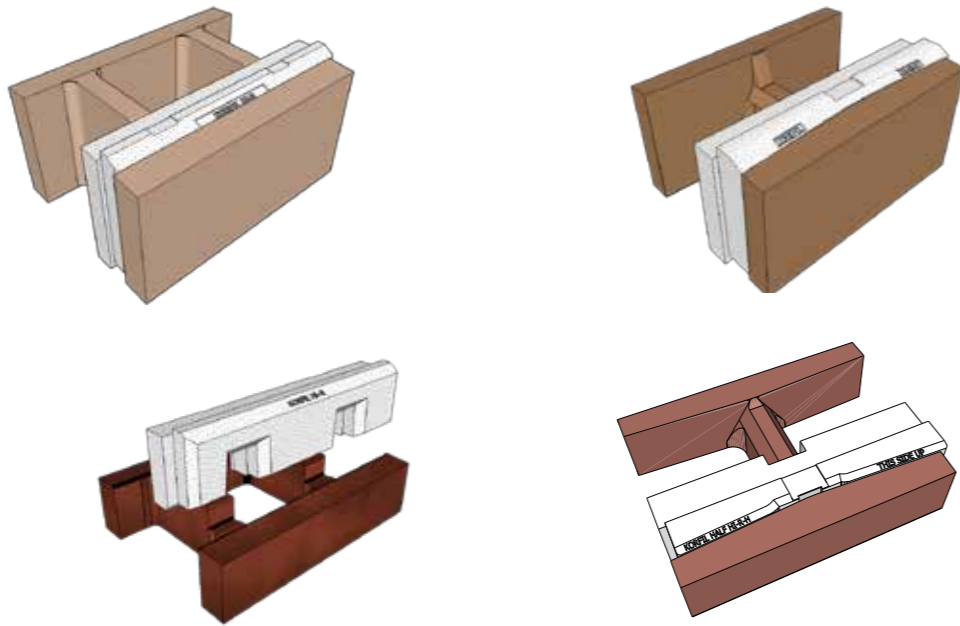

- 3. Locate Insulation Inserts toward the Exterior of the Wall.** Typically the blocks should be oriented so that the inserts are located toward the exterior of the wall, as shown below. If your plans indicate a different orientation, check with the designer to confirm that it was intentional.

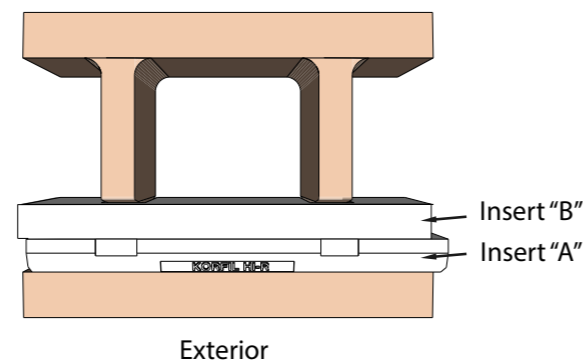

- 4. After Laying Block, Tap Insert Into Place.** You will notice that the inserts have two interlocking parts which are referred to as the "A" insert (located toward the exterior of the block) and the "B" Insert (located toward the interior of the block). The inserts are designed to form lapping joints when placed in the wall both with blocks located above and below and to both sides to provide superior insulation. As you build each course, be sure to tap or push the "B" Insert downwards to position it correctly to form a tight joint with the inserts below. At the end of each work day, make sure

the "B" Inserts on the top course are tapped down into place to avoid a height gain when work is recommenced due to excess mortar getting Handling Inserts on the Starter Course. Either carefully avoid leaving excess mortar under the "B" insert or remove the "B" insert on the starter course. This is done to make certain any mortar that may have fallen under the inner insert does not prevent inserts on the next course from being pushed downward.

- 5. Grouting and Reinforcing Hi-R and Hi-R H Walls.** The Hi-R product is suitable for both full and partial grouting. The Hi-R H products is designed for only for fully grouted walls. The webs in Hi-R blocks will align when they are placed in either a running bond or stack bond pattern providing an unobstructed cavity for grouting and re-bar placement. The reduced height of the Hi-R H single web will allow grout to flow between units and is suitable for fully grouted walls in either running or stack bond patterns. When building partially grouted Hi-R Walls, request that the webs be full height. This will eliminate the need to mortar the reduced height webs. under the insert and hardening.

Grout Information

Unit	Grout volume per unit (cubic inches)	Grout ft ³ per ft ² of wall area (fully grouted)
Hi-R 8-8-16 Smooth	215.2 in ³	.140 ft ³
Hi-R 8-8-16 Split	215.2 in ³	.140 ft ³
Hi-R 10-8-16 Smooth/Split	398.8 in ³	.260 ft ³
Hi-R 12-8-16 smooth/split	582 in ³	.379 ft ³
Hi-R-12-4-16	291 in ³	.379 ft ³
Hi-R-H 12-8-16 Smooth	551 in ³	.358 ft ³
Hi-R-H 12-8-16 Split	551 in ³	.358 ft ³
Hi-R-H 10-8-16 smooth	325 in ³	.211 ft ³
Hi-R-H 10-8-16 split	325 in ³	.211 ft ³
Hi-R-H 12-4-16	241.5 in ³	.315 ft ³
Hi-R-H 12-4-16 Jamb unit	182.1 in ³	.237 ft ³

- 6. Building Bond Beams.** For Korfil Hi-R units, check with your local manufacturer for available bond beam units. For Hi-R H units, the standard Hi-R H unit may be used as a bond beam unit without the need for any modifications.
- 7. Anticipate Vertical Rebar Placement.** Provide the General Contractor information on the proper spacing and location for vertical rebar placement in grade beam to avoid having to bend rods or cut block.
- 8. Joint Reinforcement Placement.** The Hi-R and Hi-R H Systems work with 9-gauge Ladder Type Wall Reinforcing with butt welded center cross ties at 16 inch increments. The ties should be placed directly over webs of blocks to allow the innermost insert to be pushed down to lock with the insert below it.

9. Corners. These details can be constructed using specialty units (available regionally – check on availability) or standard masonry fittings and rigid insulation.

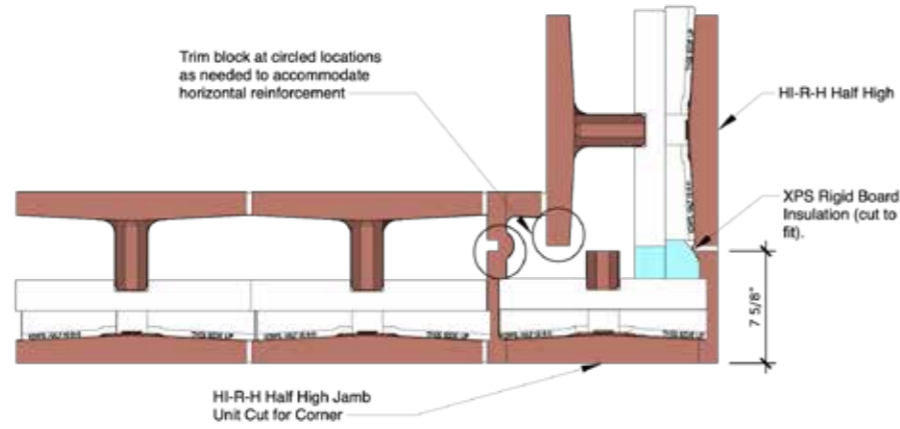

Corner Constructed Using Specialty HI-R-H Jamb and Corner Unit

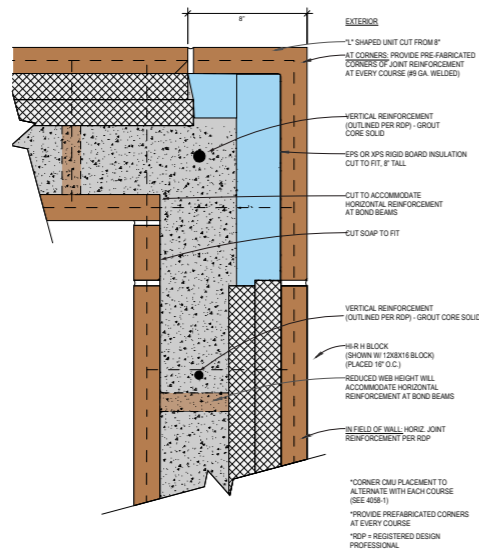

Corner Constructed Using Concrete Masonry Unit Fittings

10. Joints and Jamb. These details can be constructed using specialty units (available regionally – check with your local manufacturer) or standard masonry fittings and rigid insulation. The HI-R-H Jamb and Corner Unit is only available in some regional markets – please check availability before specifying.

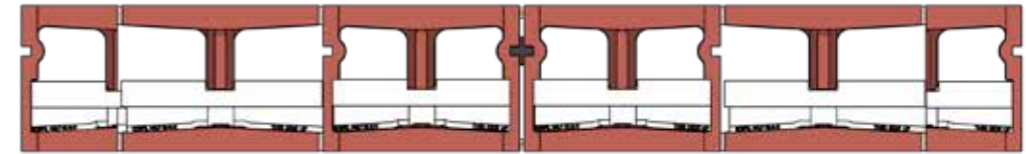

Movement Joint Constructed Using Specialty HI-R-H Jamb and Corner Unit

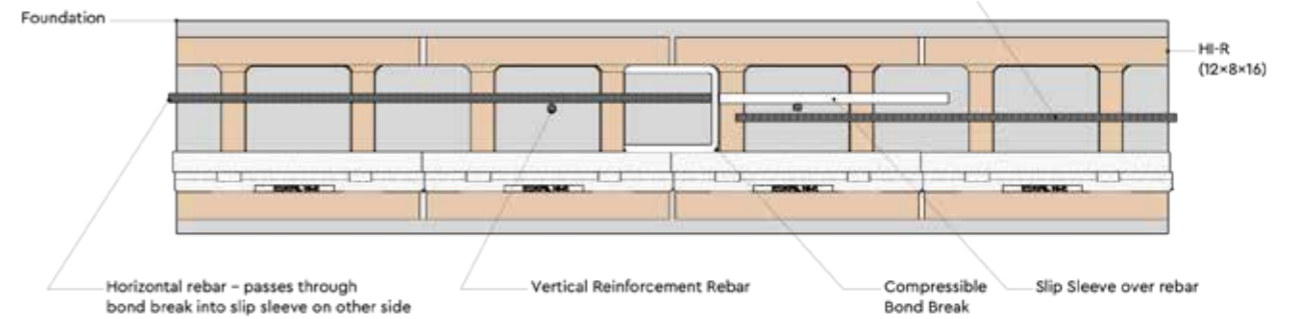

Michigan Style Soft Joint Constructed Using HI-R Units (Not Feasible with HI-R-H style units)

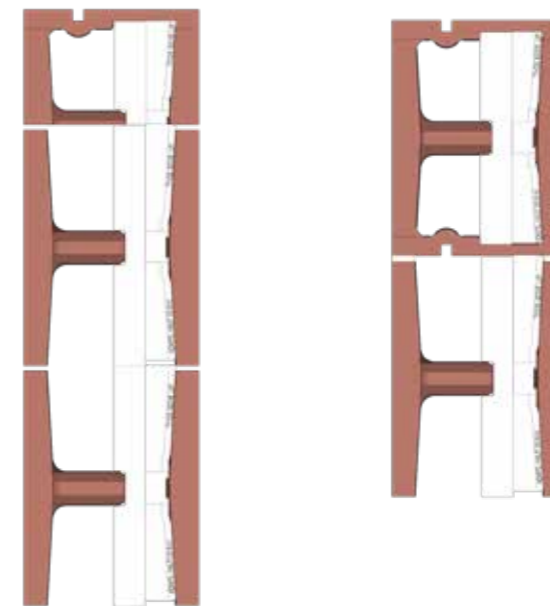

Jamb Constructed with HI-R-H/ HI-R-H Half High Jamb Unit

Mortar Joints. Tool joints when mortar has reached thumbprint hardness. Avoid use of raked joints on exterior sides of walls because raked joints will encourage moisture penetration. Concave joints will offer better weather protection.

Avoid Chippage. Care should be taken in job site handling to avoid chippage and breakage. Your forklift operator should exercise caution on rough terrain.

Loadbearing Points. Delete inserts at load-bearing points directly under bar joist, pre-cast beams, etc. Consult your project architect and engineer for approval

Store or Dispose of Loose Inserts. Since the inserts are relatively light and can be moved by wind, collect and secure any loose inserts on the job site.

Architectural Masonry Construction Best Practices. For Architectural Masonry, please refer to "Spec-Brik® Construction Best Practices" available from the Concrete Products Group LLC.

For more information, contact CPG at 1-800-789-0872 or info@concreteproductsgroup.com



Construction Details

A small thumbnail of the Table of Contents is located in the bottom right corner. It shows a list of page numbers and corresponding section titles, including 'Table of Contents', 'Introduction', 'Construction Details', and 'Appendix'. The text is too small to read clearly.

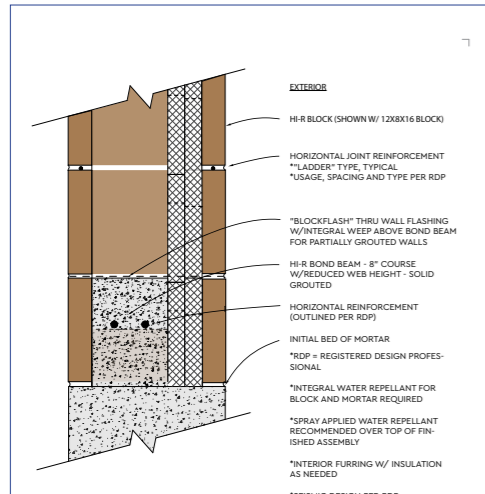

Figure 1. HI-R Bond Beam at Base of Wall

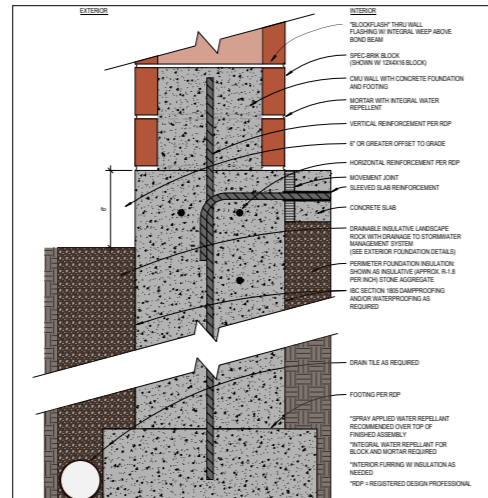

Figure 2. Landscaping and Drainage Considerations

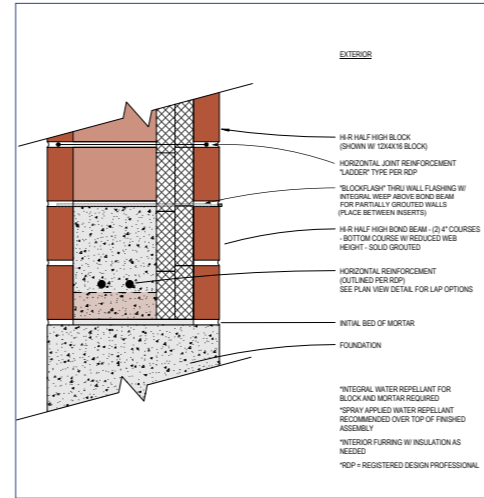

Figure 3. Spec-Brik HI-R Bond Beam (Partially Grouted Wall)

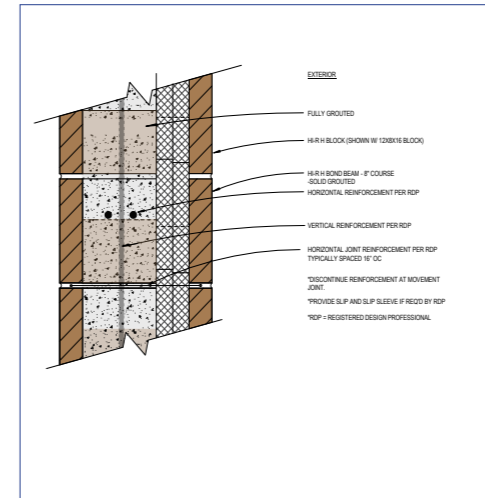

Figure 4. HI-R-H Bond Beam (Fully Grouted Wall)

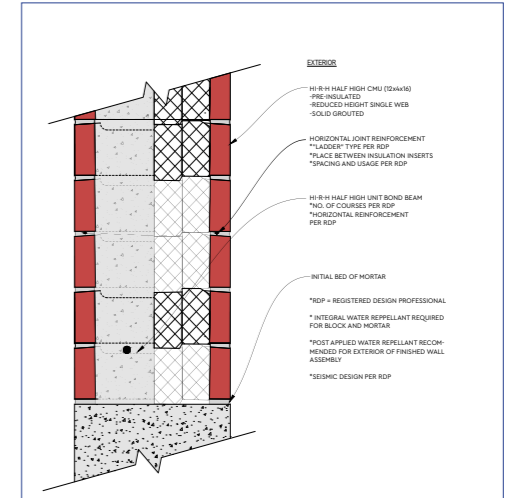

Figure 5. HI-R-H Half High Bond Beam (Fully Grouted Wall)

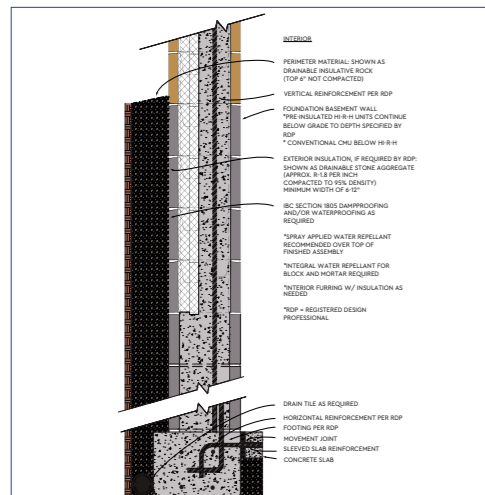

Figure 6. HI-R-H Basement Wall

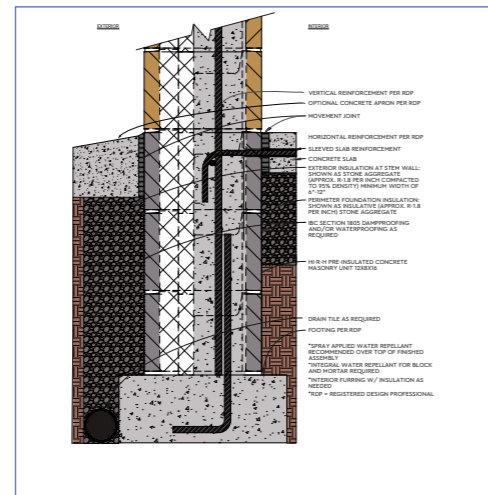

Figure 7. HI-R-H Foundation Stem Wall

Table of Contents

- Figure 1. HI-R Bond Beam at Base of Wall
- Figure 2. Landscaping and Drainage Considerations
- Figure 3. Spec-Brik HI-R Bond Beam (Partially Grouted Wall)
- Figure 4. HI-R-H Bond Beam (Fully Grouted Wall)
- Figure 5. HI-R-H Half High Bond Beam (Fully Grouted Wall)
- Figure 6. HI-R-H Basement Wall
- Figure 7. HI-R-H Foundation Stem Wall

Click on drawings to enlarge

Base of Wall and Bond Beam

Figure 1. HI-R Bond Beam and Pad, Partially Grouted

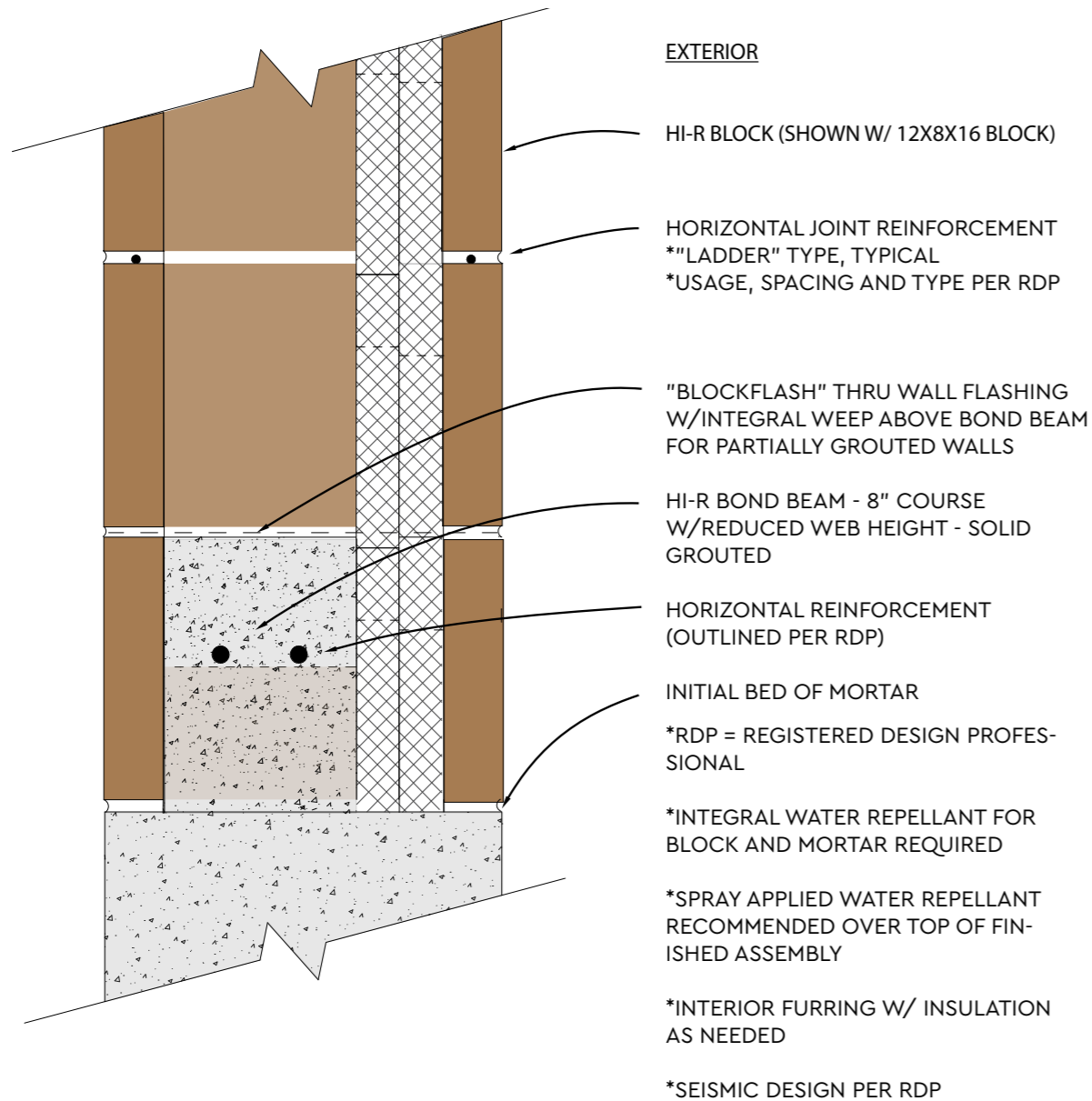

Notes

1. Consult with Structural and/or Geotechnical Engineers for appropriate below-grade insulation material and placement.
2. For weather protection, use Integral Water Repellent (IWR) in the block and mortar. Some exceptions may apply such as for California shear wall testing. Partially grouted walls require an air barrier to meet Code requirements.
3. Fully grouted masonry walls are a cost-effective alternative to partially grouted walls. In many areas of the country where seismic design considerations are important, highly reinforced and fully grouted masonry is the preferred solution. Fully grouted walls do not require flashing at bond beam locations, and meet Code air barrier requirements.

Codes and Standards References

Applicable References are found in Section III.

THE DETAILS PRESENTED IN THIS MANUAL ARE STANDARD DETAILS. DESIGNERS SHOULD MAKE SITE SPECIFIC INVESTIGATIONS TO DETERMINE ACTUAL DESIGN REQUIREMENTS, WHICH MAY VARY.

CPG IS NOT RESPONSIBLE FOR USES OF THIS INFORMATION BY THIRD PARTIES, AND DOES NOT WARRANT THE FITNESS OR SUITABILITY OF THIS INFORMATION FOR ANY PURPOSE. PERSONS MAKING USE OF THIS INFORMATION DO SO AT THEIR OWN RISK.

THESE STANDARD DETAILS ARE MEANT TO ILLUSTRATE GENERAL PRINCIPLES THAT MAY BE HELPFUL, HOWEVER, FINAL DESIGN AND CONSTRUCTION SHOULD BE BASED ON ACTUAL SITE CONDITIONS AND APPLICABLE LOCAL CODE AND STANDARDS. MANY SITE OR LOCAL CONDITIONS MAY REQUIRE SPECIFIC ADDITIONAL DESIGN CONSIDERATIONS. SUCH CONDITIONS MAY INCLUDE SEISMIC ACTIVITY, LOCAL CLIMATE, WIND LOAD AND STORM CONDITIONS (INCLUDING LIKELIHOOD OF TORNADO OR HURRICANE CONDITIONS), SITE SOILS AND DRAINAGE CONSIDERATIONS, AND A VARIETY OF OTHER FACTORS THAT MAY IMPACT BUILDING PERFORMANCE ON A PARTICULAR SITE.



Figure 2. Base of Wall, All Unit Types: Landscaping Considerations

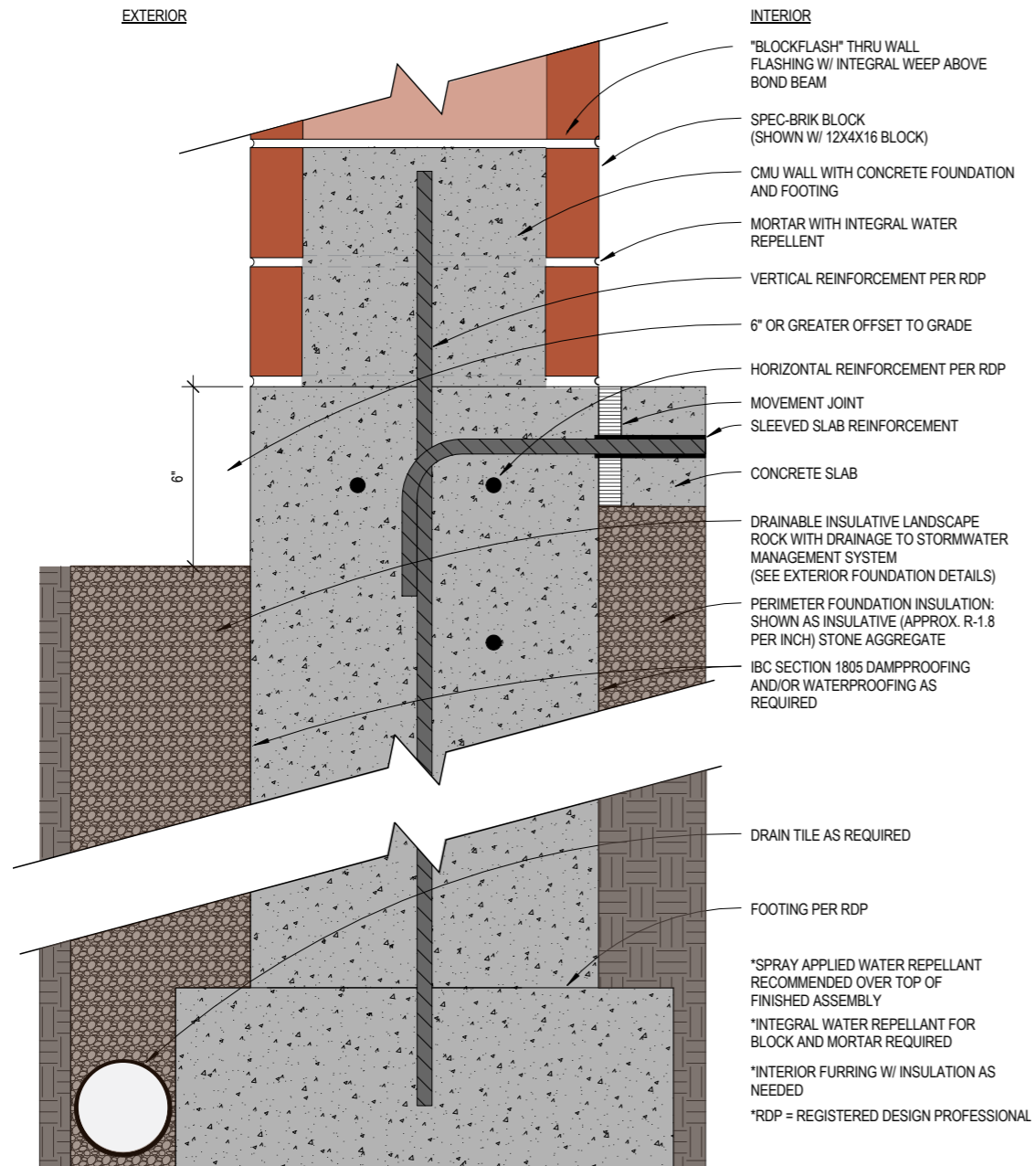

1. If the zone near the base of wall is to be landscaped, do not place plant life, roots, irrigation, fertilizers or other chemicals within 3 feet of the footing, foundation wall, foundation, and slab. Isolate the footing, foundation and slab from such elements. The height of the soil and nearby draining curbs should be at least 6 inches below top of finished floor to prevent damage from accumulated mulch, and absorption, pooling or flooding of water.
2. Minimum 6" soil/top of finished floor/footing elevation offset. Within this 6" deep offset, a drainable landscape layer of lightweight insulative aggregate may be placed. This in turn can be combined with a minimum 6" - 12" wide 95% compacted lightweight insulative aggregate zone extending down to spread footing with perforated drainage collection pipe at spread footing. The drainage collection pipe leads to a stormwater drainage system.
3. If landscaping is to be used near the structure, maintain a minimum distance of five feet between the vegetation and irrigation from any lightweight insulative aggregate zone. Trees minimum distance 30'.
4. Isolate the zone near the wall from landscape sprinklers or irrigation.

THE DETAILS PRESENTED IN THIS MANUAL ARE STANDARD DETAILS. DESIGNERS SHOULD MAKE SITE SPECIFIC INVESTIGATIONS TO DETERMINE ACTUAL DESIGN REQUIREMENTS, WHICH MAY VARY.

CPG IS NOT RESPONSIBLE FOR USES OF THIS INFORMATION BY THIRD PARTIES, AND DOES NOT WARRANT THE FITNESS OR SUITABILITY OF THIS INFORMATION FOR ANY PURPOSE. PERSONS MAKING USE OF THIS INFORMATION DO SO AT THEIR OWN RISK.

THESE STANDARD DETAILS ARE MEANT TO ILLUSTRATE GENERAL PRINCIPLES THAT MAY BE HELPFUL, HOWEVER, FINAL DESIGN AND CONSTRUCTION SHOULD BE BASED ON ACTUAL SITE CONDITIONS AND APPLICABLE LOCAL CODE AND STANDARDS. MANY SITE OR LOCAL CONDITIONS MAY REQUIRE SPECIFIC ADDITIONAL DESIGN CONSIDERATIONS. SUCH CONDITIONS MAY INCLUDE SEISMIC ACTIVITY, LOCAL CLIMATE, WIND LOAD AND STORM CONDITIONS (INCLUDING LIKELIHOOD OF TORNADO OR HURRICANE CONDITIONS), SITE SOILS AND DRAINAGE CONSIDERATIONS, AND A VARIETY OF OTHER FACTORS THAT MAY IMPACT BUILDING PERFORMANCE ON A PARTICULAR SITE.

Figure 3. Exterior, Poured Foundation and Pad

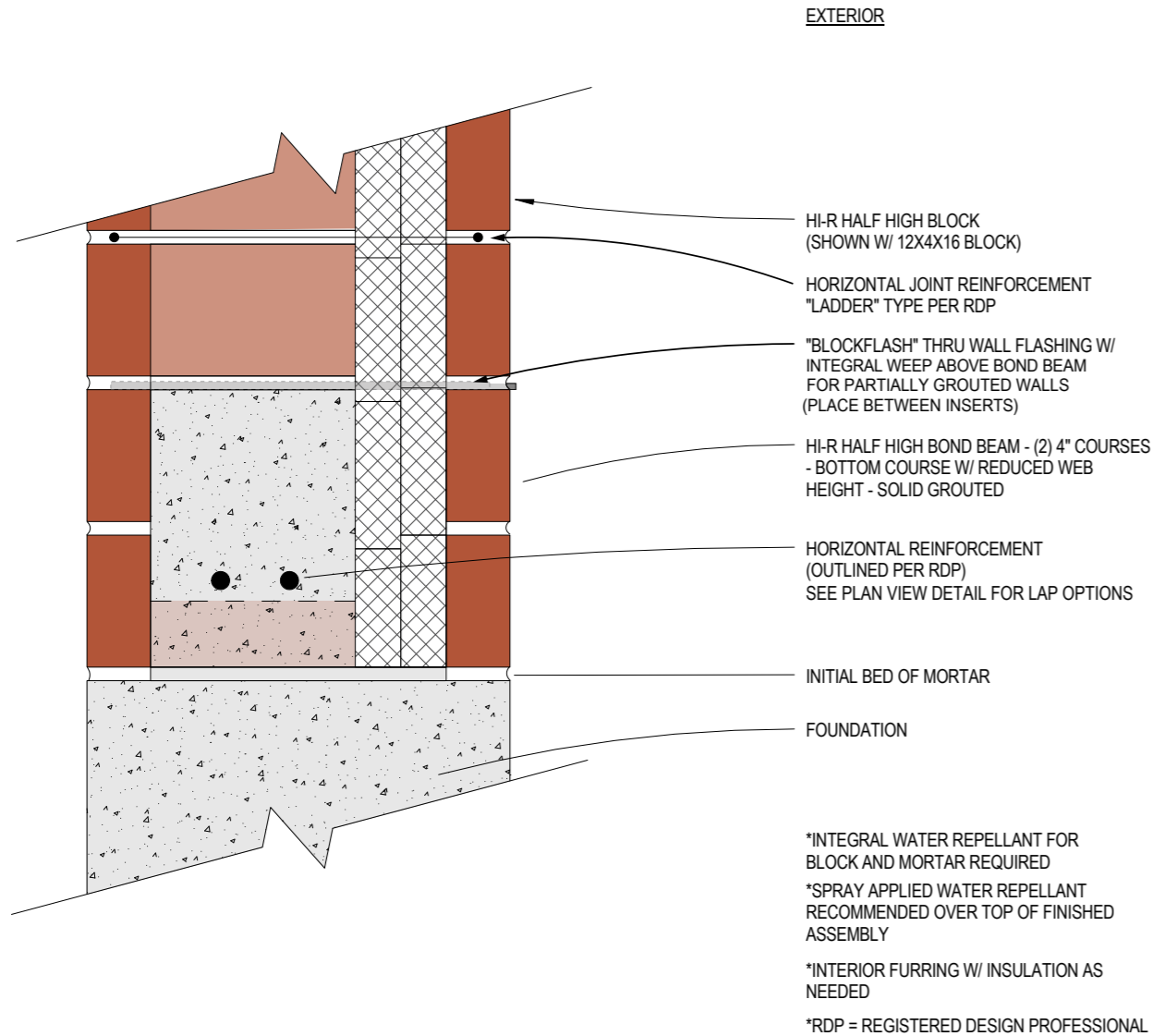

Notes

1. Consult with Structural and/or Geotechnical Engineers for appropriate below-grade insulation material and placement.
2. For weather protection, use Integral Water Repellent (IWR) in the block and mortar. Some exceptions may apply such as for California shear wall testing. We also recommend the use of a clear, breathable post-applied water repellent. Partially Grouted Walls will require an air barrier.
3. Fully grouting masonry walls is an excellent and cost-effective alternative to partially grouted walls. In many areas of the country where seismic design considerations are important, highly reinforced and fully grouted masonry is the preferred solution. Fully grouted walls do not require flashing at bond beam locations, and meet Code air barrier requirements.
4. See Figure 6 for Plan View of Michigan Style Movement Joint.

Codes and Standards References

Applicable References are found in Section III.

THE DETAILS PRESENTED IN THIS MANUAL ARE STANDARD DETAILS. DESIGNERS SHOULD MAKE SITE SPECIFIC INVESTIGATIONS TO DETERMINE ACTUAL DESIGN REQUIREMENTS, WHICH MAY VARY.

CPG IS NOT RESPONSIBLE FOR USES OF THIS INFORMATION BY THIRD PARTIES, AND DOES NOT WARRANT THE FITNESS OR SUITABILITY OF THIS INFORMATION FOR ANY PURPOSE. PERSONS MAKING USE OF THIS INFORMATION DO SO AT THEIR OWN RISK.

THESE STANDARD DETAILS ARE MEANT TO ILLUSTRATE GENERAL PRINCIPLES THAT MAY BE HELPFUL, HOWEVER, FINAL DESIGN AND CONSTRUCTION SHOULD BE BASED ON ACTUAL SITE CONDITIONS AND APPLICABLE LOCAL CODE AND STANDARDS. MANY SITE OR LOCAL CONDITIONS MAY REQUIRE SPECIFIC ADDITIONAL DESIGN CONSIDERATIONS. SUCH CONDITIONS MAY INCLUDE SEISMIC ACTIVITY, LOCAL CLIMATE, WIND LOAD AND STORM CONDITIONS (INCLUDING LIKELIHOOD OF TORNADO OR HURRICANE CONDITIONS), SITE SOILS AND DRAINAGE CONSIDERATIONS, AND A VARIETY OF OTHER FACTORS THAT MAY IMPACT BUILDING PERFORMANCE ON A PARTICULAR SITE.



Figure 4. HI-R-H – Fully Grouted Bond Beam

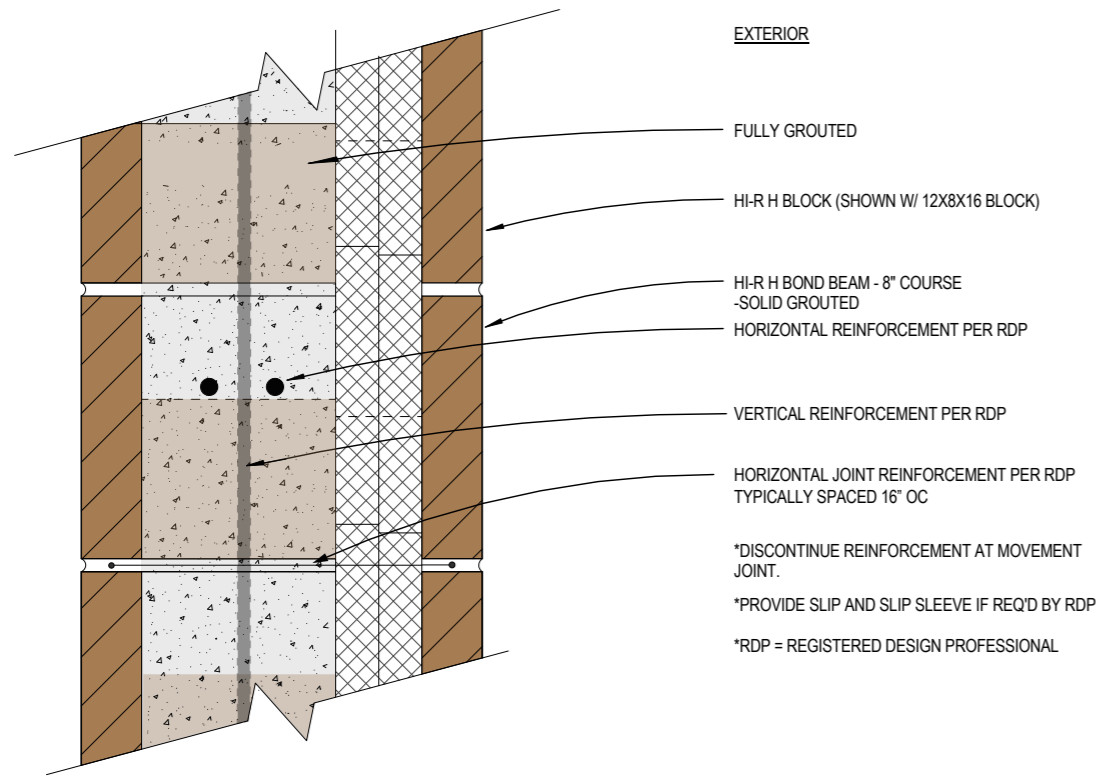

Notes

1. For weather protection, use Integral Water Repellent (IWR) in the block and mortar. Some exceptions may apply such as for California shear wall testing. We also recommend the use of a clear, breathable post-applied water repellent.
2. Request evidence in writing of, or special inspection for, adequate head joint mortar bond to IWR-containing CMU for Properties-based mortars.
3. The HI-R-H units are suitable for use as bond beam units without modification or removal of the insulative inserts.
4. Fully grouting masonry walls is an excellent and cost-effective alternative to partially grouted walls. In many areas of the country where seismic design considerations are important, highly reinforced and fully grouted masonry is the preferred solution. Fully grouted walls do not require flashing at bond beam locations, and meet Code air barrier requirements.

Codes and Standards References

Applicable References are found in Section III.

THE DETAILS PRESENTED IN THIS MANUAL ARE STANDARD DETAILS. DESIGNERS SHOULD MAKE SITE SPECIFIC INVESTIGATIONS TO DETERMINE ACTUAL DESIGN REQUIREMENTS, WHICH MAY VARY.

CPG IS NOT RESPONSIBLE FOR USES OF THIS INFORMATION BY THIRD PARTIES, AND DOES NOT WARRANT THE FITNESS OR SUITABILITY OF THIS INFORMATION FOR ANY PURPOSE. PERSONS MAKING USE OF THIS INFORMATION DO SO AT THEIR OWN RISK.

THESE STANDARD DETAILS ARE MEANT TO ILLUSTRATE GENERAL PRINCIPLES THAT MAY BE HELPFUL, HOWEVER, FINAL DESIGN AND CONSTRUCTION SHOULD BE BASED ON ACTUAL SITE CONDITIONS AND APPLICABLE LOCAL CODE AND STANDARDS. MANY SITE OR LOCAL CONDITIONS MAY REQUIRE SPECIFIC ADDITIONAL DESIGN CONSIDERATIONS. SUCH CONDITIONS MAY INCLUDE SEISMIC ACTIVITY, LOCAL CLIMATE, WIND LOAD AND STORM CONDITIONS (INCLUDING LIKELIHOOD OF TORNADO OR HURRICANE CONDITIONS), SITE SOILS AND DRAINAGE CONSIDERATIONS, AND A VARIETY OF OTHER FACTORS THAT MAY IMPACT BUILDING PERFORMANCE ON A PARTICULAR SITE.



Figure 5. HI-R-H Half High – Fully Grouted Bond Beam at Wall Base

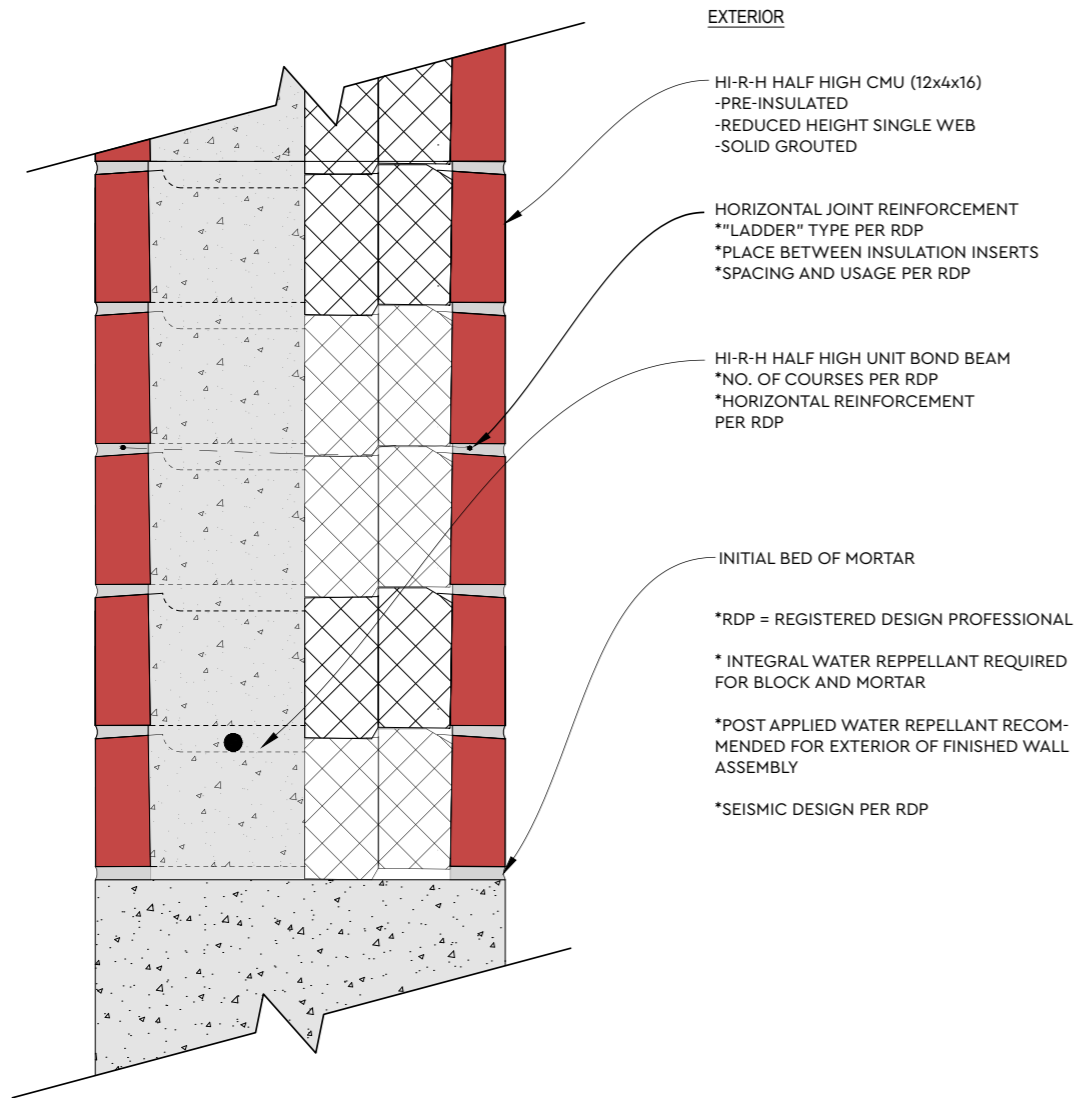

Notes

1. For weather protection, use Integral Water Repellent (IWR) in the block and mortar. Some exceptions may apply, such as for California shear wall testing. We also recommend the use of a clear, breathable post-applied water repellent.
2. Request evidence in writing of, or special inspection for, adequate head joint mortar bond to IWR-containing CMU for Properties-based mortars.
3. The HI-R-H Half High units are suitable for use as bond beam units without modification or removal of the insulative inserts.
4. Fully grouting masonry walls is an excellent and cost-effective alternative to partially grouted walls. In many areas of the country where seismic design considerations are important, highly reinforced and fully grouted masonry is the preferred solution. Fully grouted walls do not require flashing at bond beam locations, and meet Code air barrier requirements.

Codes and Standards References

Applicable References are found in Section III.

THE DETAILS PRESENTED IN THIS MANUAL ARE STANDARD DETAILS. DESIGNERS SHOULD MAKE SITE SPECIFIC INVESTIGATIONS TO DETERMINE ACTUAL DESIGN REQUIREMENTS, WHICH MAY VARY.

CPG IS NOT RESPONSIBLE FOR USES OF THIS INFORMATION BY THIRD PARTIES, AND DOES NOT WARRANT THE FITNESS OR SUITABILITY OF THIS INFORMATION FOR ANY PURPOSE. PERSONS MAKING USE OF THIS INFORMATION DO SO AT THEIR OWN RISK.

THESE STANDARD DETAILS ARE MEANT TO ILLUSTRATE GENERAL PRINCIPLES THAT MAY BE HELPFUL, HOWEVER, FINAL DESIGN AND CONSTRUCTION SHOULD BE BASED ON ACTUAL SITE CONDITIONS AND APPLICABLE LOCAL CODE AND STANDARDS. MANY SITE OR LOCAL CONDITIONS MAY REQUIRE SPECIFIC ADDITIONAL DESIGN CONSIDERATIONS. SUCH CONDITIONS MAY INCLUDE SEISMIC ACTIVITY, LOCAL CLIMATE, WIND LOAD AND STORM CONDITIONS (INCLUDING LIKELIHOOD OF TORNADO OR HURRICANE CONDITIONS), SITE SOILS AND DRAINAGE CONSIDERATIONS, AND A VARIETY OF OTHER FACTORS THAT MAY IMPACT BUILDING PERFORMANCE ON A PARTICULAR SITE.



Figure 6. HI-R-H and CMU Basement Wall

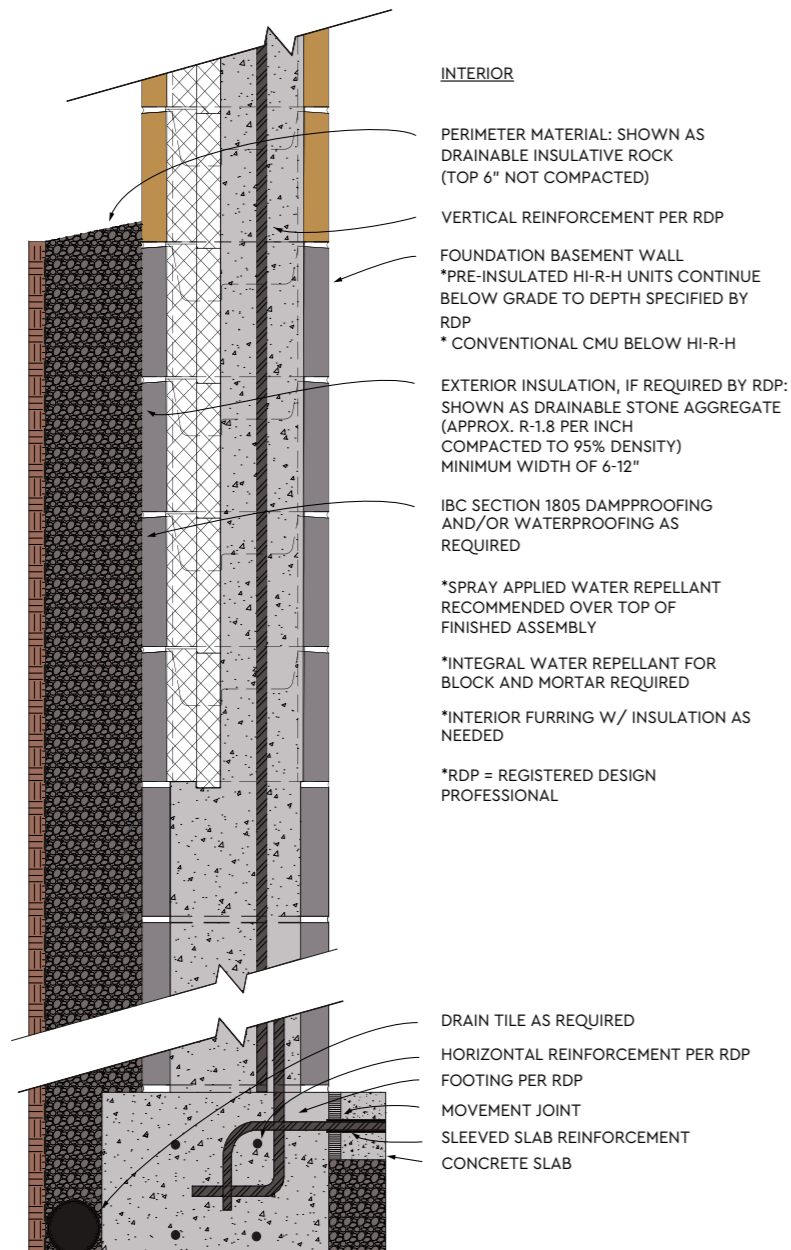

THE DETAILS PRESENTED IN THIS MANUAL ARE STANDARD DETAILS. DESIGNERS SHOULD MAKE SITE SPECIFIC INVESTIGATIONS TO DETERMINE ACTUAL DESIGN REQUIREMENTS, WHICH MAY VARY.

CPG IS NOT RESPONSIBLE FOR USES OF THIS INFORMATION BY THIRD PARTIES, AND DOES NOT WARRANT THE FITNESS OR SUITABILITY OF THIS INFORMATION FOR ANY PURPOSE. PERSONS MAKING USE OF THIS INFORMATION DO SO AT THEIR OWN RISK.

THESE STANDARD DETAILS ARE MEANT TO ILLUSTRATE GENERAL PRINCIPLES THAT MAY BE HELPFUL, HOWEVER, FINAL DESIGN AND CONSTRUCTION SHOULD BE BASED ON ACTUAL SITE CONDITIONS AND APPLICABLE LOCAL CODE AND STANDARDS. MANY SITE OR LOCAL CONDITIONS MAY REQUIRE SPECIFIC ADDITIONAL DESIGN CONSIDERATIONS. SUCH CONDITIONS MAY INCLUDE SEISMIC ACTIVITY, LOCAL CLIMATE, WIND LOAD AND STORM CONDITIONS (INCLUDING LIKELIHOOD OF TORNADO OR HURRICANE CONDITIONS), SITE SOILS AND DRAINAGE CONSIDERATIONS, AND A VARIETY OF OTHER FACTORS THAT MAY IMPACT BUILDING PERFORMANCE ON A PARTICULAR SITE.

Notes

1. For weather protection, use Integral Water Repellent (IWR) in the block and mortar. Some exceptions may apply, such as for California shear wall testing. We also recommend the use of a clear, breathable post-applied water repellent.
2. Request evidence in writing of, or special inspection for, adequate head joint mortar bond to IWR-containing CMU for Properties-based mortars.
3. The HI-R-H Half High units are suitable for use as bond beam units without modification or removal of the insulative inserts.
4. Fully grouting masonry walls is an excellent and cost-effective alternative to partially grouted walls. In many areas of the country where seismic design considerations are important, highly reinforced and fully grouted masonry is the preferred solution. Fully grouted walls do not require flashing at bond beam locations, and meet Code air barrier requirements.

Codes and Standards References

Applicable References are found in Section III.

Figure 7. HI-R-H Foundation Stem Wall

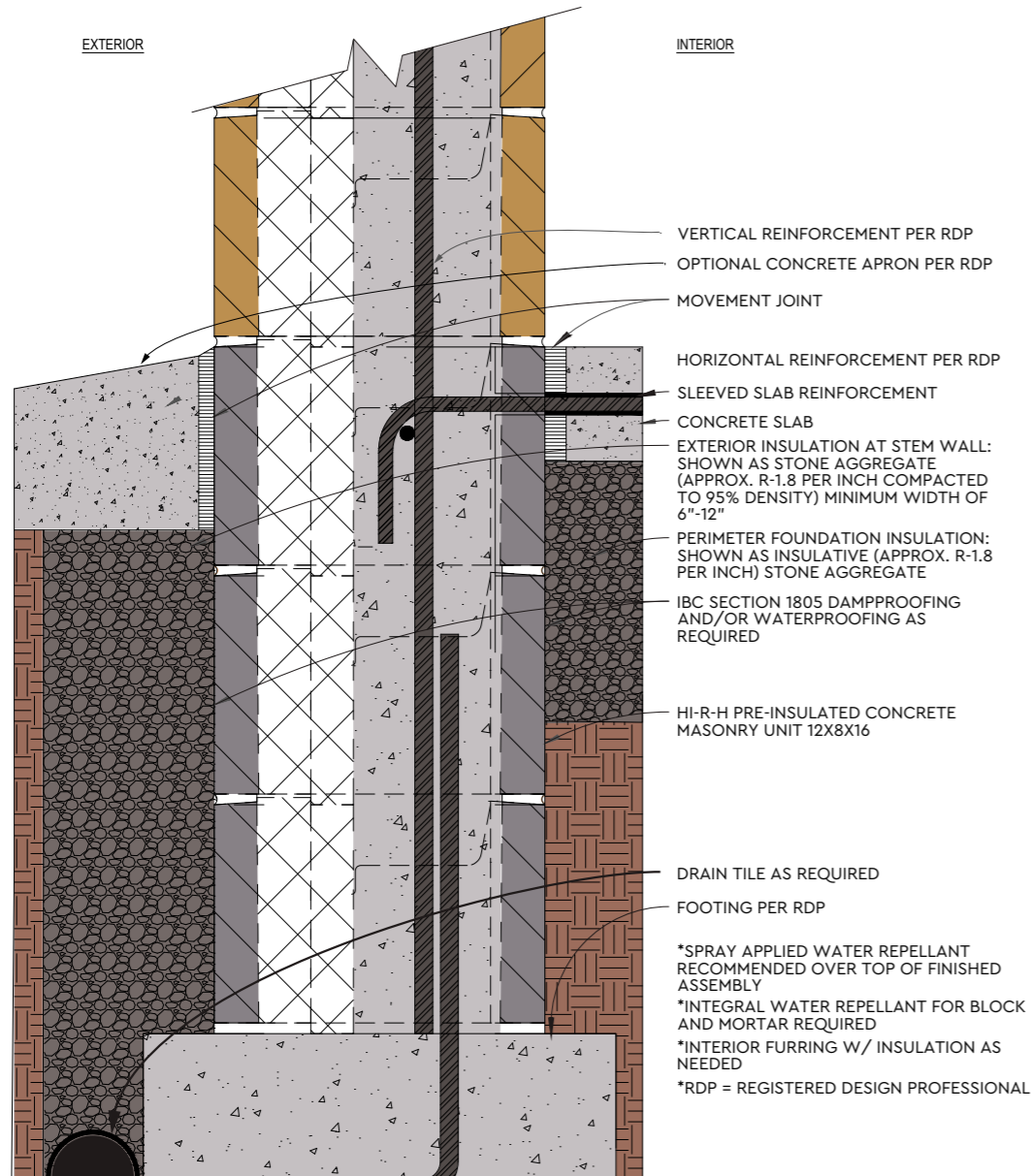

Notes

1. For weather protection, use Integral Water Repellent (IWR) in the block and mortar. Some exceptions may apply, such as for California shear wall testing. We also recommend the use of a clear, breathable post-applied water repellent.
2. Request evidence in writing of, or special inspection for, adequate head joint mortar bond to IWR-containing CMU for Properties-based mortars.
3. The HI-R-H Half High units are suitable for use as bond beam units without modification or removal of the insulative inserts.
4. Fully grouting masonry walls is an excellent and cost-effective alternative to partially grouted walls. In many areas of the country where seismic design considerations are important, highly reinforced and fully grouted masonry is the preferred solution. Fully grouted walls do not require flashing at bond beam locations, and meet Code air barrier requirements.
5. Detail XXXX in Concrete Products Group CAD Library.

Codes and Standards References

Applicable References are found in Section III.

THE DETAILS PRESENTED IN THIS MANUAL ARE STANDARD DETAILS. DESIGNERS SHOULD MAKE SITE SPECIFIC INVESTIGATIONS TO DETERMINE ACTUAL DESIGN REQUIREMENTS, WHICH MAY VARY.

CPG IS NOT RESPONSIBLE FOR USES OF THIS INFORMATION BY THIRD PARTIES, AND DOES NOT WARRANT THE FITNESS OR SUITABILITY OF THIS INFORMATION FOR ANY PURPOSE. PERSONS MAKING USE OF THIS INFORMATION DO SO AT THEIR OWN RISK.

THESE STANDARD DETAILS ARE MEANT TO ILLUSTRATE GENERAL PRINCIPLES THAT MAY BE HELPFUL, HOWEVER, FINAL DESIGN AND CONSTRUCTION SHOULD BE BASED ON ACTUAL SITE CONDITIONS AND APPLICABLE LOCAL CODE AND STANDARDS. MANY SITE OR LOCAL CONDITIONS MAY REQUIRE SPECIFIC ADDITIONAL DESIGN CONSIDERATIONS. SUCH CONDITIONS MAY INCLUDE SEISMIC ACTIVITY, LOCAL CLIMATE, WIND LOAD AND STORM CONDITIONS (INCLUDING LIKELIHOOD OF TORNADO OR HURRICANE CONDITIONS), SITE SOILS AND DRAINAGE CONSIDERATIONS, AND A VARIETY OF OTHER FACTORS THAT MAY IMPACT BUILDING PERFORMANCE ON A PARTICULAR SITE.

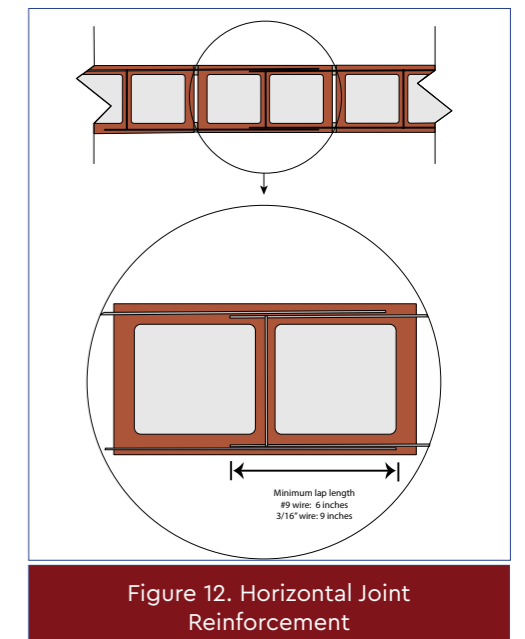
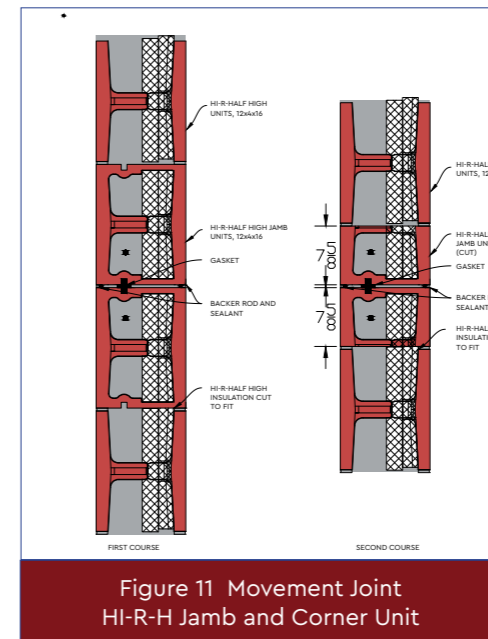
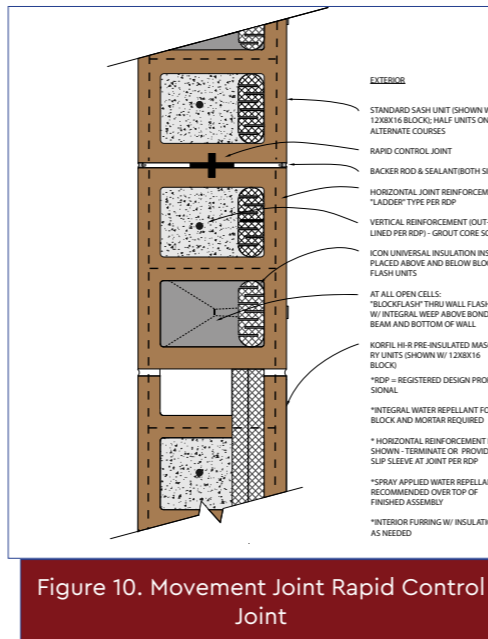
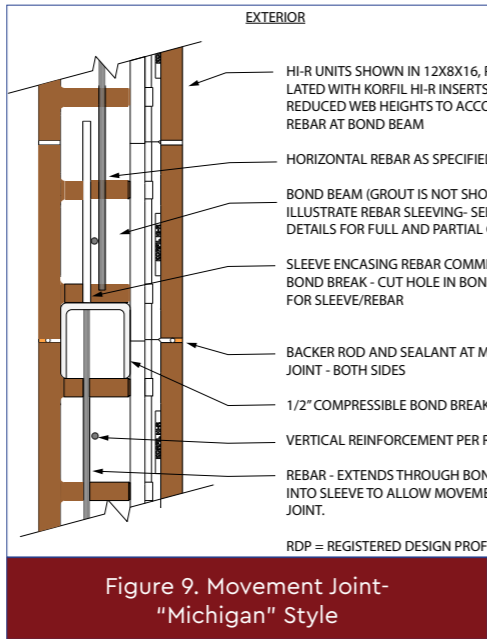
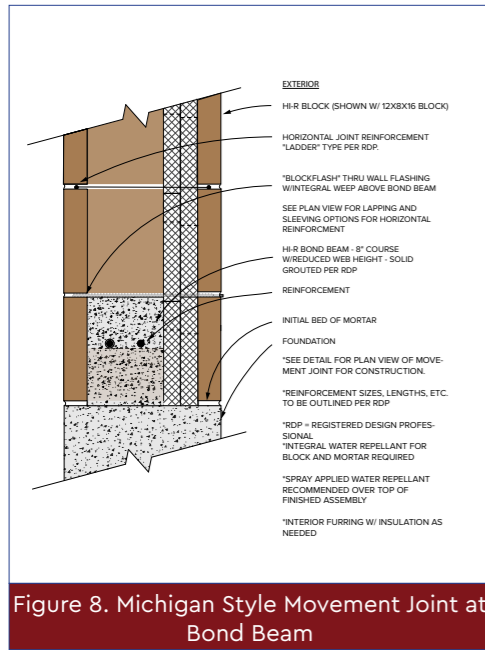

Figure 8. Michigan Style Movement Joint at Bond Beam

Figure 9. Movement Joint- "Michigan" Style

Figure 10. Movement Joint Rapid Control Joint

Figure 11 Movement Joint HI-R-H Jamb and Corner Unit

Figure 12. Horizontal Joint Reinforcement

Table of Contents

- 1. Introduction
- 2. Michigan Style Movement Joint at Bond Beam
- 3. Movement Joint- "Michigan" Style
- 4. Movement Joint Rapid Control Joint
- 5. Movement Joint HI-R-H Jamb and Corner Unit
- 6. Horizontal Joint Reinforcement

Click on drawings to enlarge

**Movement Joints
 Horizontal Joint Reinforcement**

Figure 8. Michigan Style Movement Joint at Bond Beam

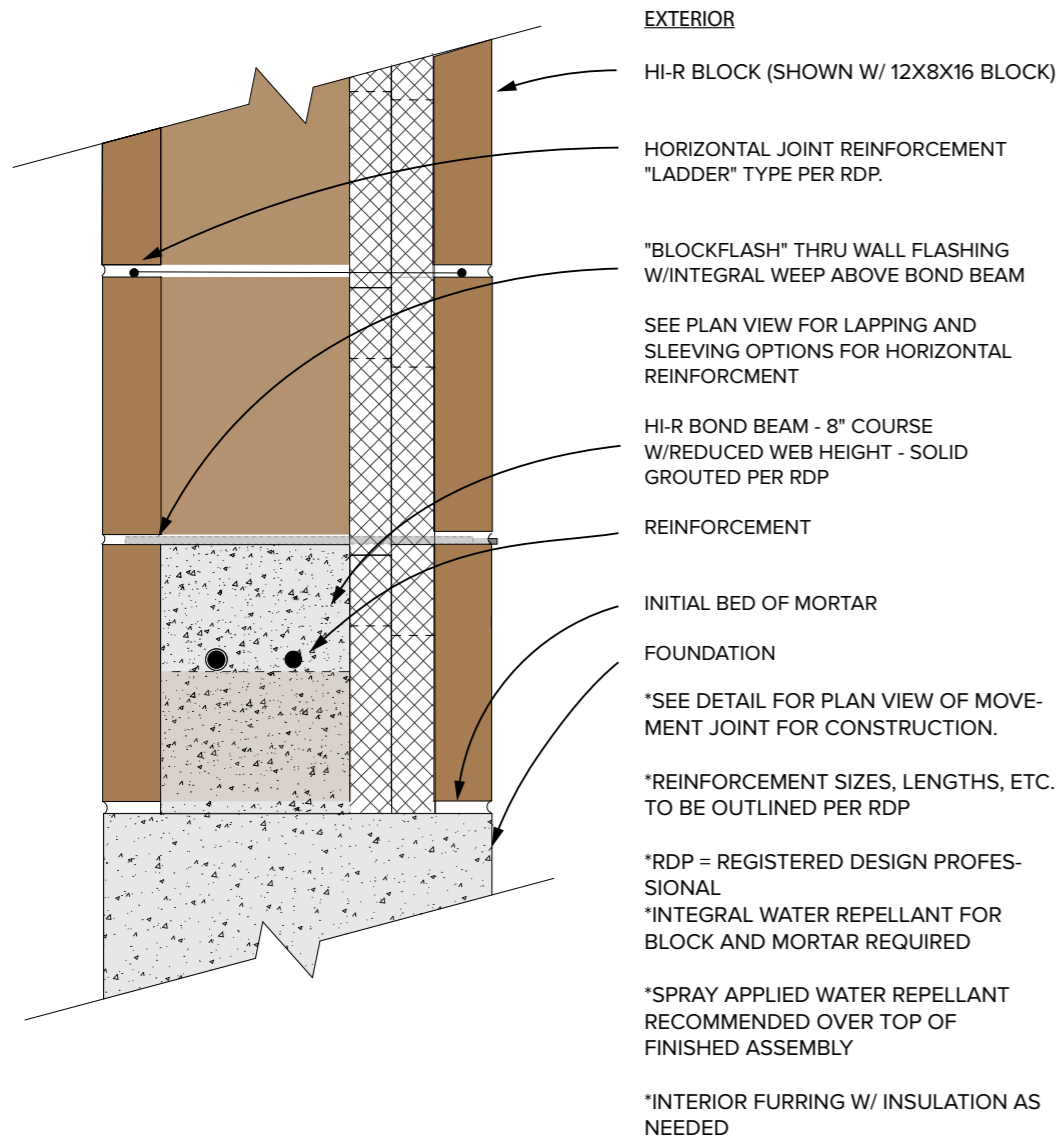

Notes

1. This detail indicates a spliced detail for the horizontal reinforcement, which should be used only if it is required by the RDP. In general, movement joints do not require spliced bars. See Figure 9 for a plan view of this detail. This detail indicates a spliced detail for the horizontal reinforcement only if it is required by the RDP. In general, movement joints do not require spliced bars.
2. Movement joints are a method to avoid cracking in masonry walls. They are advisable in areas where there are interfaces with materials that may have different expansion properties than the wall as a whole and at regular intervals in the field of the wall. Placing movement joints will accommodate any slight differential in expansion/contraction properties. The movement joint is sealed with a gasket and sealants for weather protection. The spacing and placement of movement joints should be reviewed by a structural engineer in accordance with NCMA TEK Notes.
3. For weather protection, use Integral Water Repellent (IWR) in the block and mortar. Some exceptions may apply such as for California shear wall testing. We also recommend the use of a clear, breathable post-applied water repellent. Partially Grouted Walls will require an air barrier.

Codes and Standards References

Applicable References are found in Section III.

THE DETAILS PRESENTED IN THIS MANUAL ARE STANDARD DETAILS. DESIGNERS SHOULD MAKE SITE SPECIFIC INVESTIGATIONS TO DETERMINE ACTUAL DESIGN REQUIREMENTS, WHICH MAY VARY.

CPG IS NOT RESPONSIBLE FOR USES OF THIS INFORMATION BY THIRD PARTIES, AND DOES NOT WARRANT THE FITNESS OR SUITABILITY OF THIS INFORMATION FOR ANY PURPOSE. PERSONS MAKING USE OF THIS INFORMATION DO SO AT THEIR OWN RISK.

THESE STANDARD DETAILS ARE MEANT TO ILLUSTRATE GENERAL PRINCIPLES THAT MAY BE HELPFUL, HOWEVER, FINAL DESIGN AND CONSTRUCTION SHOULD BE BASED ON ACTUAL SITE CONDITIONS AND APPLICABLE LOCAL CODE AND STANDARDS. MANY SITE OR LOCAL CONDITIONS MAY REQUIRE SPECIFIC ADDITIONAL DESIGN CONSIDERATIONS. SUCH CONDITIONS MAY INCLUDE SEISMIC ACTIVITY, LOCAL CLIMATE, WIND LOAD AND STORM CONDITIONS (INCLUDING LIKELIHOOD OF TORNADO OR HURRICANE CONDITIONS), SITE SOILS AND DRAINAGE CONSIDERATIONS, AND A VARIETY OF OTHER FACTORS THAT MAY IMPACT BUILDING PERFORMANCE ON A PARTICULAR SITE.



Figure 9. Movement Joint- "Michigan" Style

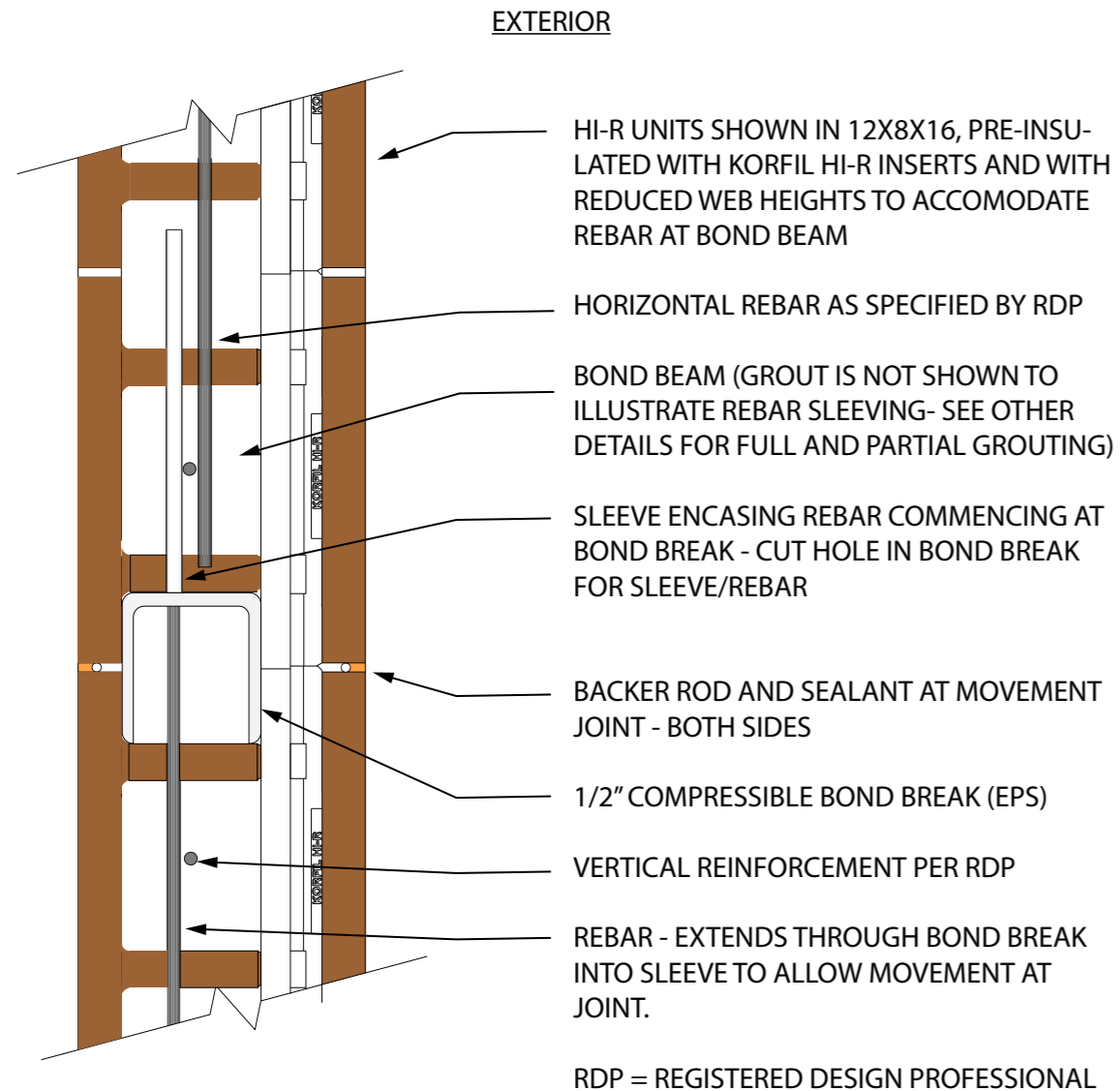

Notes

1. This detail indicates a spliced detail for the horizontal reinforcement, which should be used only if it is required by the RDP. In general, movement joints do not require spliced bars.
2. Movement joints are a method to avoid cracking in masonry walls. They are advisable in areas where there are interfaces with materials that may have different expansion properties than the wall as a whole and at regular intervals in the field of the wall. Placing movement joints will accommodate any slight differential in expansion/contraction properties. The spacing and placement of movement joints should be reviewed by a structural engineer in accordance with NCMA TEK Notes.
3. For weather protection, use Integral Water Repellent (IWR) in the block and mortar. Some exceptions may apply such as for California shear wall testing. The movement joint is sealed with a gasket and sealants for weather protection. We also recommend the use of a clear, breathable post-applied water repellent. Partially Grouted Walls will require an air barrier.
4. This style of Movement Joint offers superior thermal performance at the joint because it does not require removal of the insulation inserts at the joint. It is suitable for use with HI-R units, but the greater core size of the HI-R-H units do not lend themselves to this approach.
5. On alternate courses, half HI-R units and insulation are placed at the joint in place of the full units shown here.

This is detail 4075A in the CPG CAD detail collection.

Codes and Standards References

Applicable References are found in Section III.

THE DETAILS PRESENTED IN THIS MANUAL ARE STANDARD DETAILS. DESIGNERS SHOULD MAKE SITE SPECIFIC INVESTIGATIONS TO DETERMINE ACTUAL DESIGN REQUIREMENTS, WHICH MAY VARY.

CPG IS NOT RESPONSIBLE FOR USES OF THIS INFORMATION BY THIRD PARTIES, AND DOES NOT WARRANT THE FITNESS OR SUITABILITY OF THIS INFORMATION FOR ANY PURPOSE. PERSONS MAKING USE OF THIS INFORMATION DO SO AT THEIR OWN RISK.

THESE STANDARD DETAILS ARE MEANT TO ILLUSTRATE GENERAL PRINCIPLES THAT MAY BE HELPFUL, HOWEVER, FINAL DESIGN AND CONSTRUCTION SHOULD BE BASED ON ACTUAL SITE CONDITIONS AND APPLICABLE LOCAL CODE AND STANDARDS. MANY SITE OR LOCAL CONDITIONS MAY REQUIRE SPECIFIC ADDITIONAL DESIGN CONSIDERATIONS. SUCH CONDITIONS MAY INCLUDE SEISMIC ACTIVITY, LOCAL CLIMATE, WIND LOAD AND STORM CONDITIONS (INCLUDING LIKELIHOOD OF TORNADO OR HURRICANE CONDITIONS), SITE SOILS AND DRAINAGE CONSIDERATIONS, AND A VARIETY OF OTHER FACTORS THAT MAY IMPACT BUILDING PERFORMANCE ON A PARTICULAR SITE.



Figure 10. Movement Joint

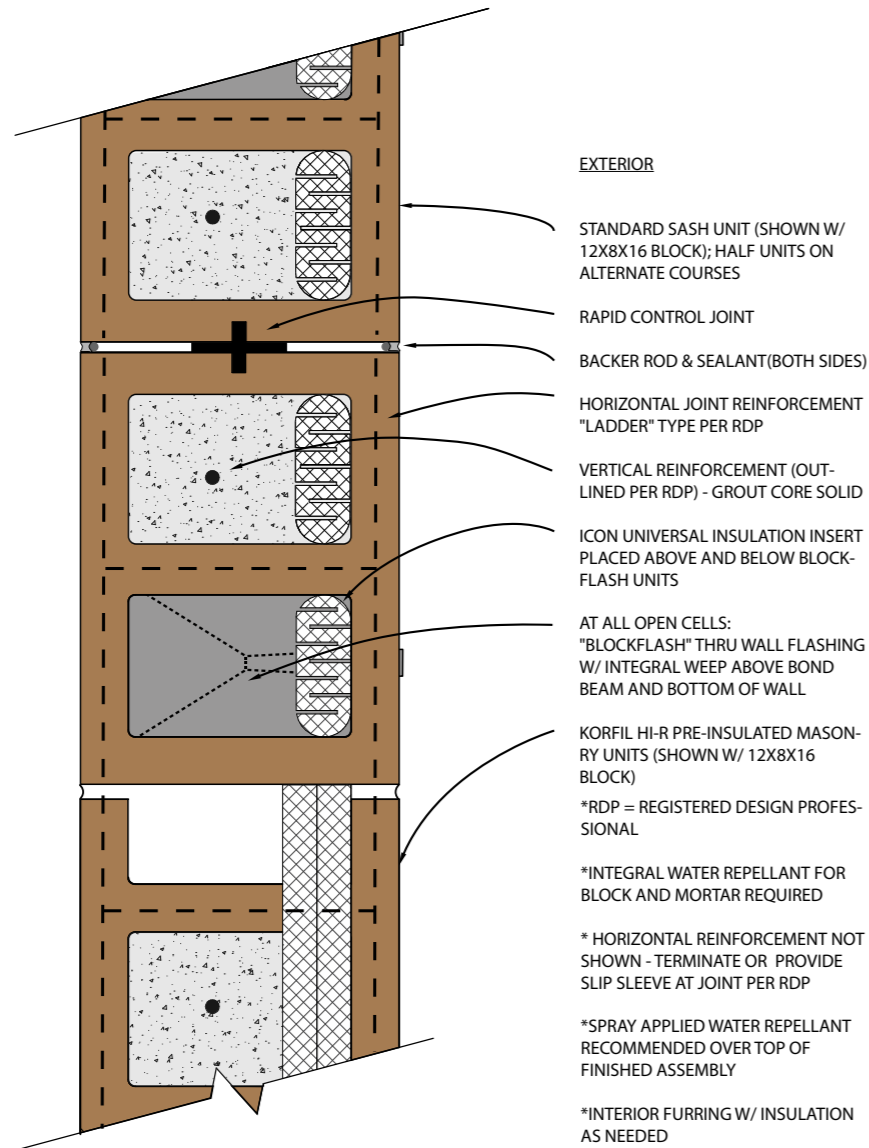

Notes

1. Movement joints are a method to avoid cracking in masonry walls. They are advisable in areas where there are interfaces with materials that may have different expansion properties than the wall as a whole and at regular intervals in the field of the wall. Placing these joints here will accommodate any slight differential in expansion/contraction properties. The movement joint will be sealed with a gasket and sealants.
2. In general, the specific spacing and placement of movement joints for a project should be reviewed by a structural engineer, in accordance with the recommendations in the NCMA TEK Notes.

Codes and Standards References

Applicable References are found in Section III.

THE DETAILS PRESENTED IN THIS MANUAL ARE STANDARD DETAILS. DESIGNERS SHOULD MAKE SITE SPECIFIC INVESTIGATIONS TO DETERMINE ACTUAL DESIGN REQUIREMENTS, WHICH MAY VARY.

CPG IS NOT RESPONSIBLE FOR USES OF THIS INFORMATION BY THIRD PARTIES, AND DOES NOT WARRANT THE FITNESS OR SUITABILITY OF THIS INFORMATION FOR ANY PURPOSE. PERSONS MAKING USE OF THIS INFORMATION DO SO AT THEIR OWN RISK.

THESE STANDARD DETAILS ARE MEANT TO ILLUSTRATE GENERAL PRINCIPLES THAT MAY BE HELPFUL, HOWEVER, FINAL DESIGN AND CONSTRUCTION SHOULD BE BASED ON ACTUAL SITE CONDITIONS AND APPLICABLE LOCAL CODE AND STANDARDS. MANY SITE OR LOCAL CONDITIONS MAY REQUIRE SPECIFIC ADDITIONAL DESIGN CONSIDERATIONS. SUCH CONDITIONS MAY INCLUDE SEISMIC ACTIVITY, LOCAL CLIMATE, WIND LOAD AND STORM CONDITIONS (INCLUDING LIKELIHOOD OF TORNADO OR HURRICANE CONDITIONS), SITE SOILS AND DRAINAGE CONSIDERATIONS, AND A VARIETY OF OTHER FACTORS THAT MAY IMPACT BUILDING PERFORMANCE ON A PARTICULAR SITE.



Figure 11. Movement Joint Using HI-R-H or HI-R-H Half High Jamb and Corner Unit

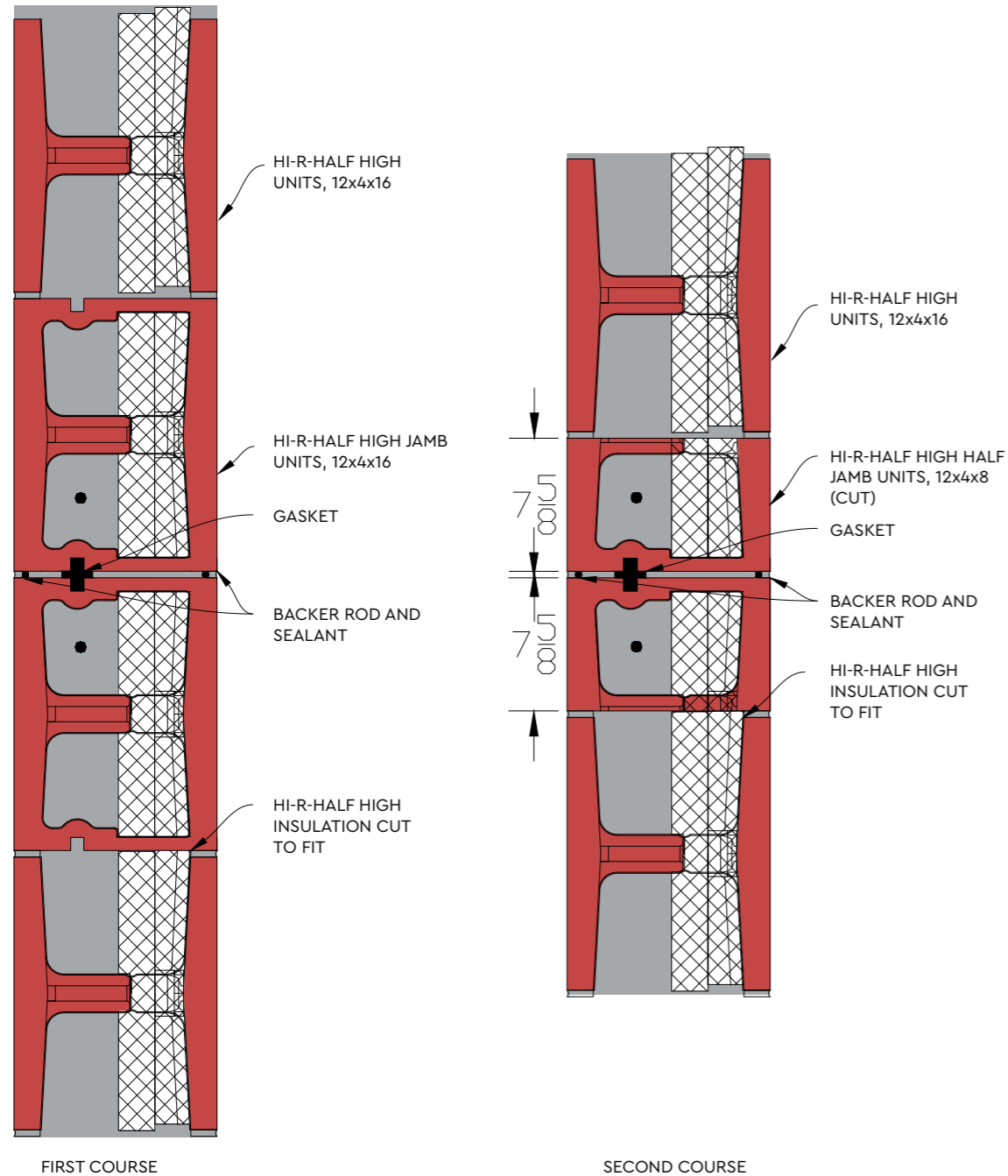

Notes

1. The HI-R-H Jamb Unit has been recently introduced and has regional availability. Check with your local manufacturer prior to specifying.
2. Movement joints are a method to avoid cracking in masonry walls. They are advisable in areas where there are interfaces with materials that may have different expansion properties than the wall as a whole and at regular intervals in the field of the wall. Placing these joints will accommodate any slight differential in expansion/contraction properties. The movement joint will be sealed with a gasket and sealants.
3. In general, the specific spacing and placement of movement joints for a project should be reviewed by a structural engineer, in accordance with the recommendations in the NCMA TEK Notes.

Codes and Standards References

Applicable References are found in Section III.

THE DETAILS PRESENTED IN THIS MANUAL ARE STANDARD DETAILS. DESIGNERS SHOULD MAKE SITE SPECIFIC INVESTIGATIONS TO DETERMINE ACTUAL DESIGN REQUIREMENTS, WHICH MAY VARY.

CPG IS NOT RESPONSIBLE FOR USES OF THIS INFORMATION BY THIRD PARTIES, AND DOES NOT WARRANT THE FITNESS OR SUITABILITY OF THIS INFORMATION FOR ANY PURPOSE. PERSONS MAKING USE OF THIS INFORMATION DO SO AT THEIR OWN RISK.

THESE STANDARD DETAILS ARE MEANT TO ILLUSTRATE GENERAL PRINCIPLES THAT MAY BE HELPFUL, HOWEVER, FINAL DESIGN AND CONSTRUCTION SHOULD BE BASED ON ACTUAL SITE CONDITIONS AND APPLICABLE LOCAL CODE AND STANDARDS. MANY SITE OR LOCAL CONDITIONS MAY REQUIRE SPECIFIC ADDITIONAL DESIGN CONSIDERATIONS. SUCH CONDITIONS MAY INCLUDE SEISMIC ACTIVITY, LOCAL CLIMATE, WIND LOAD AND STORM CONDITIONS (INCLUDING LIKELIHOOD OF TORNADO OR HURRICANE CONDITIONS), SITE SOILS AND DRAINAGE CONSIDERATIONS, AND A VARIETY OF OTHER FACTORS THAT MAY IMPACT BUILDING PERFORMANCE ON A PARTICULAR SITE.



Figure 12. Joint Reinforcement

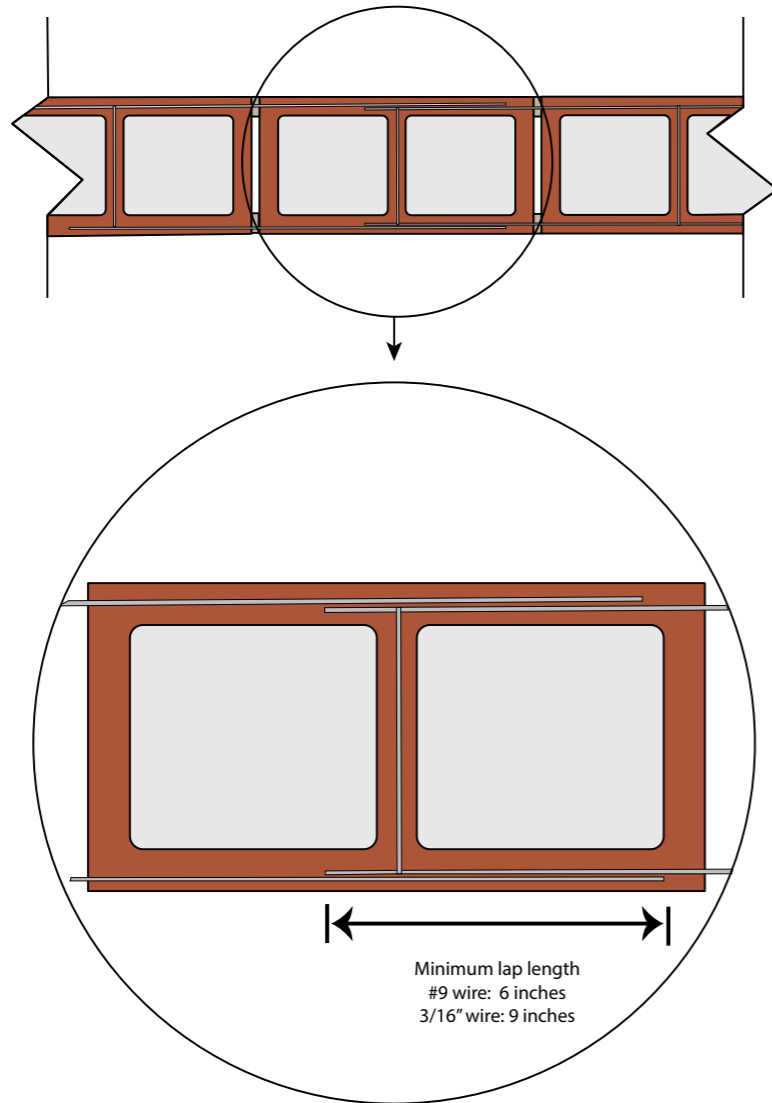

Notes

1. Lapping the joint reinforcement is required by Code and typically specified. However, the failure to execute this detail properly during construction is a common source of cracking issues. If cracking is found, forensic testing will often show lack of continuity of the joint reinforcement at the location of cracks that are found in the field of the wall.
2. Typical recommendations are for 16" vertical spacing for 8" nominal height units and 12" for 4" nominal height units. The Registered Design Professional may elect to limit or not use horizontal joint reinforcement for walls that have sufficient horizontal reinforcement from reinforcement rebar including fully grouted walls. See NCMA TEK Notes for recommendations for horizontal joint reinforcement spacing.
3. Horizontal joint reinforcement terminates at movement joints.

Codes and Standards References

Applicable References are found in Section III.

THE DETAILS PRESENTED IN THIS MANUAL ARE STANDARD DETAILS. DESIGNERS SHOULD MAKE SITE SPECIFIC INVESTIGATIONS TO DETERMINE ACTUAL DESIGN REQUIREMENTS, WHICH MAY VARY.

CPG IS NOT RESPONSIBLE FOR USES OF THIS INFORMATION BY THIRD PARTIES, AND DOES NOT WARRANT THE FITNESS OR SUITABILITY OF THIS INFORMATION FOR ANY PURPOSE. PERSONS MAKING USE OF THIS INFORMATION DO SO AT THEIR OWN RISK.

THESE STANDARD DETAILS ARE MEANT TO ILLUSTRATE GENERAL PRINCIPLES THAT MAY BE HELPFUL, HOWEVER, FINAL DESIGN AND CONSTRUCTION SHOULD BE BASED ON ACTUAL SITE CONDITIONS AND APPLICABLE CODES AND STANDARDS. MANY SITE OR LOCAL CONDITIONS MAY REQUIRE SPECIFIC ADDITIONAL DESIGN CONSIDERATIONS. SUCH CONDITIONS MAY INCLUDE SEISMIC ACTIVITY, LOCAL CLIMATE, WIND LOAD AND STORM CONDITIONS (INCLUDING LIKELIHOOD OF TORNADO OR HURRICANE CONDITIONS), SITE SOILS AND DRAINAGE CONSIDERATIONS, AND A VARIETY OF OTHER FACTORS THAT MAY IMPACT BUILDING PERFORMANCE ON A PARTICULAR SITE.



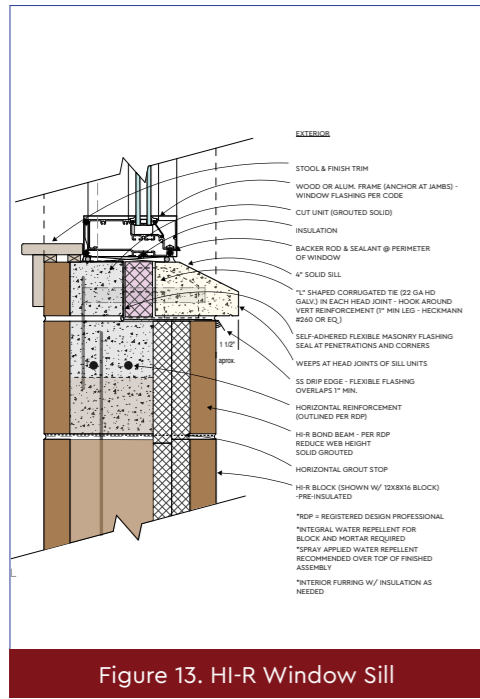

Figure 13. HI-R Window Sill

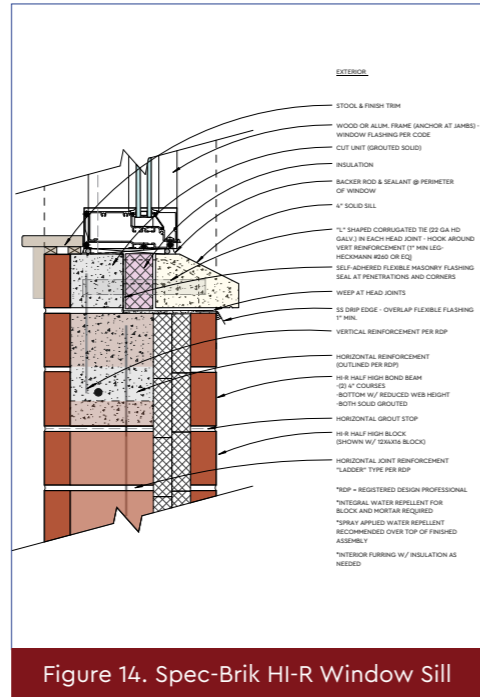

Figure 14. Spec-Brik HI-R Window Sill

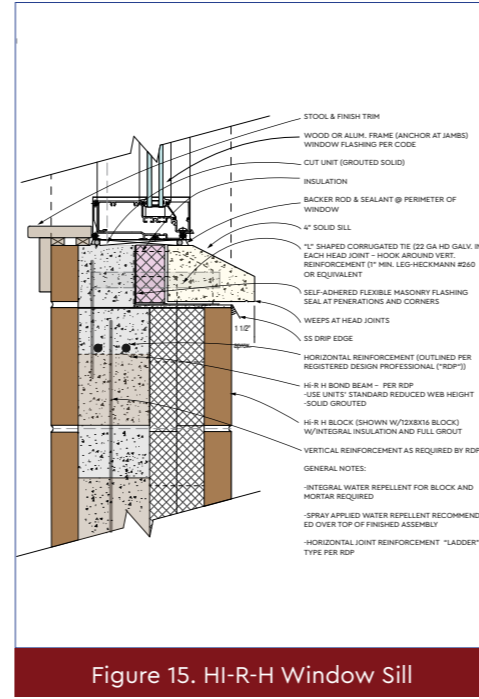

Figure 15. HI-R-H Window Sill

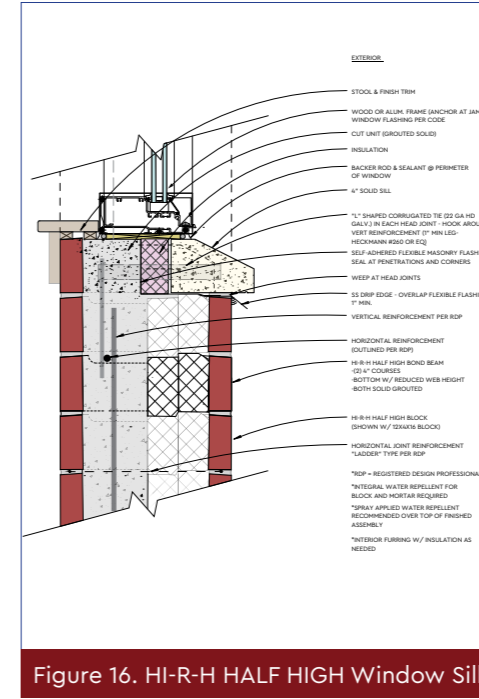

Figure 16. HI-R-H HALF HIGH Window Sill

[Click on drawings to enlarge](#)

Table of Contents	
1	Introduction
2	Window Sills
3	Window Frames
4	Window Glazing
5	Window Accessories
6	Window Installation
7	Window Maintenance
8	Window Safety
9	Window Energy Efficiency
10	Window Sound Attenuation
11	Window Security
12	Window Aesthetics
13	Window Sustainability
14	Window Innovation
15	Window Future Trends

Window Sills

Figure 13. HI-R Window Sill (Partially Grouted Wall)

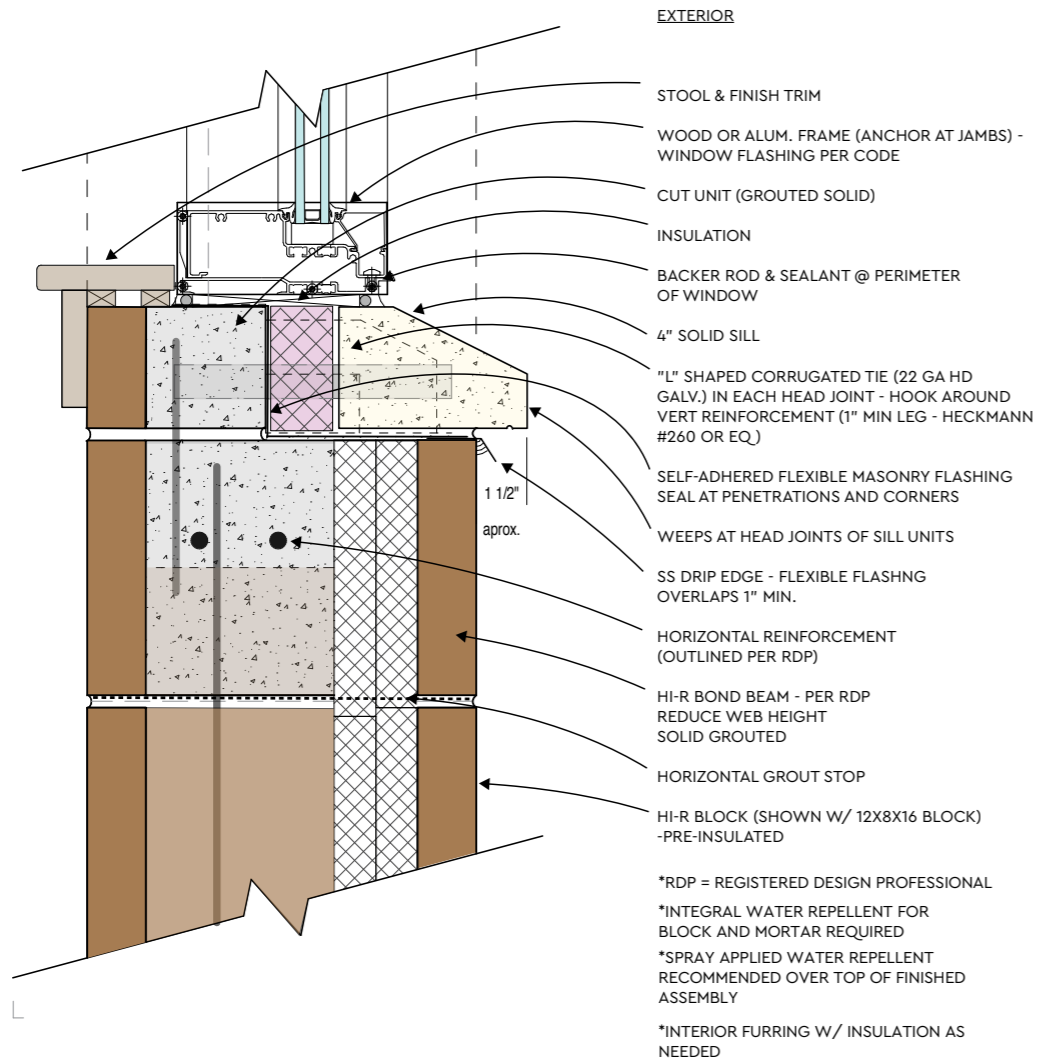

Notes:

1. This detail depicts a partially grouted wall. HI-R CMU may also be used to construct fully grouted walls and would be detailed in the same manner, other than excluding the grout stop below the sill bond beam. Fully grouting masonry walls is a cost-effective alternative to partially grouted walls. In many areas of the country where seismic design considerations are important, highly reinforced and fully grouted masonry is the preferred solution. Fully grouted walls do not require flashing at bond beam locations (though flashing at a sill location as shown is recommended), and meet Code air barrier requirements.
2. For projects located in California, or other projects where compliance to vertical wall shear testing is required, alternate moisture control techniques that omit integral water repellent may be used (e.g. use IWR within mortar; use post-applied breathable penetrating sealants or drainable film forming coatings; use High Range Water Reducer in grout).
3. Request evidence in writing of adequate head joint mortar bond to IWR-containing CMU for Properties-based mortars. Request in writing evidence of sufficient composite-action bond to IWR-containing CMU of Properties-based grout.
4. Single wythe walls rely upon a belt-and-suspenders approach to moisture control. Design typically will integrate flashing and weeps, integral water repellent, post-applied moisture control means and measures, sealants, movement joints, damp-checks, crack control, thermal bridging/condensate control, as well as soil elevation offsets and below-grade damp-proofing.

Codes and Standards References

Applicable References are found in Section III.

THE DETAILS PRESENTED IN THIS MANUAL ARE STANDARD DETAILS. DESIGNERS SHOULD MAKE SITE SPECIFIC INVESTIGATIONS TO DETERMINE ACTUAL DESIGN REQUIREMENTS, WHICH MAY VARY.

CPG IS NOT RESPONSIBLE FOR USES OF THIS INFORMATION BY THIRD PARTIES, AND DOES NOT WARRANT THE FITNESS OR SUITABILITY OF THIS INFORMATION FOR ANY PURPOSE. PERSONS MAKING USE OF THIS INFORMATION DO SO AT THEIR OWN RISK.

THESE STANDARD DETAILS ARE MEANT TO ILLUSTRATE GENERAL PRINCIPLES THAT MAY BE HELPFUL, HOWEVER, FINAL DESIGN AND CONSTRUCTION SHOULD BE BASED ON ACTUAL SITE CONDITIONS AND APPLICABLE LOCAL CODE AND STANDARDS. MANY SITE OR LOCAL CONDITIONS MAY REQUIRE SPECIFIC ADDITIONAL DESIGN CONSIDERATIONS. SUCH CONDITIONS MAY INCLUDE SEISMIC ACTIVITY, LOCAL CLIMATE, WIND LOAD AND STORM CONDITIONS (INCLUDING LIKELIHOOD OF TORNADO OR HURRICANE CONDITIONS), SITE SOILS AND DRAINAGE CONSIDERATIONS, AND A VARIETY OF OTHER FACTORS THAT MAY IMPACT BUILDING PERFORMANCE ON A PARTICULAR SITE.



Figure 14. Spec-Brik HI-R Window Sill

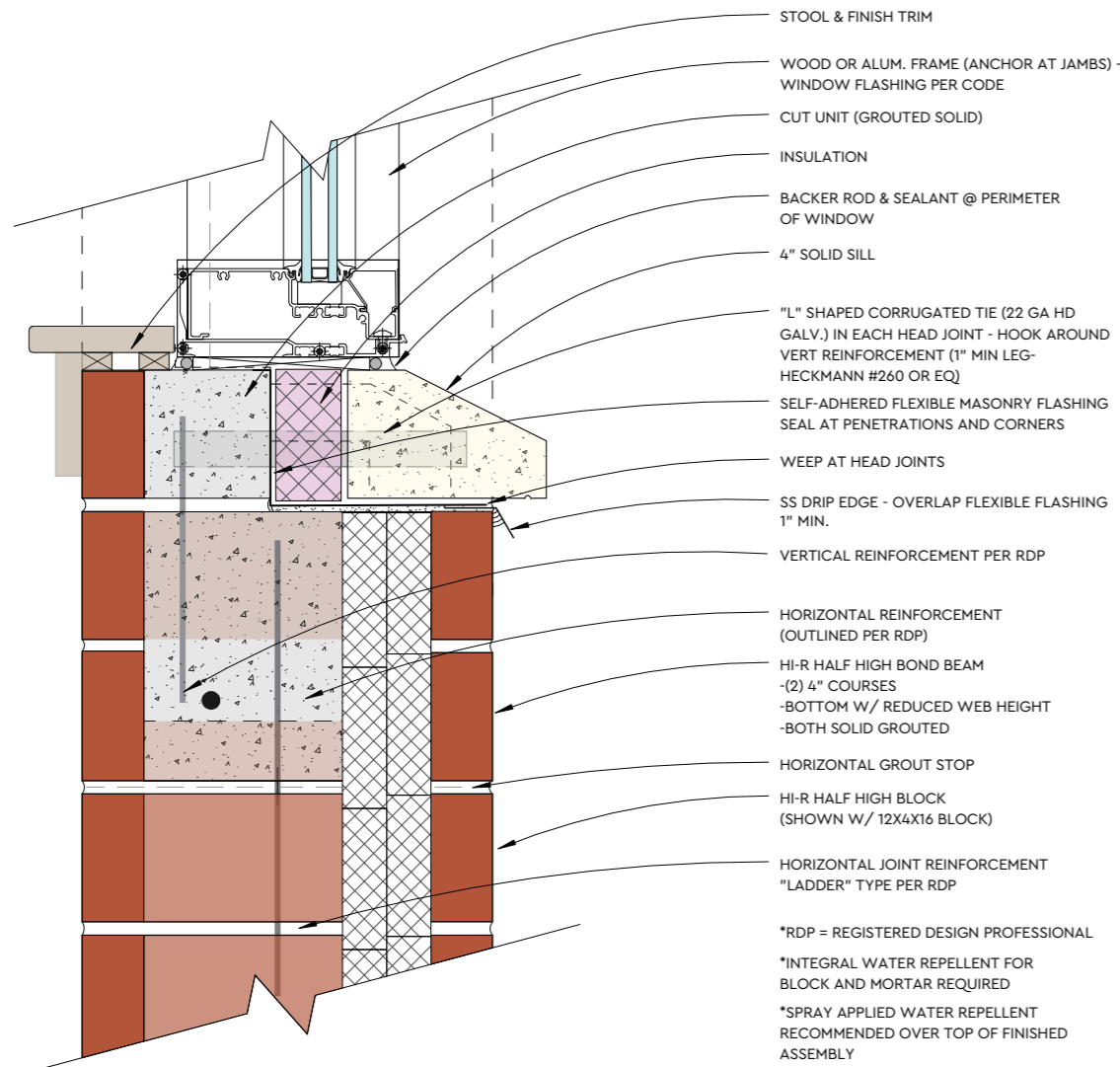

Notes:

1. This detail depicts a partially grouted wall. HI-R CMU may also be used to construct fully grouted walls and would be detailed in the same manner, other than excluding the grout stop below the sill bond beam. Fully grouting masonry walls is a cost-effective alternative to partially grouted walls. In many areas of the country where seismic design considerations are important, highly reinforced and fully grouted masonry is the preferred solution. Fully grouted walls do not require flashing at bond beam locations (though flashing at a sill location as shown is recommended), and meet Code air barrier requirements.
2. For projects located in California, or other projects where compliance to vertical wall shear testing is required, alternate moisture control techniques that omit integral water repellent may be used (e.g. use IWR within mortar; use post-applied breathable penetrating sealants or drainable film forming coatings; use High Range Water Reducer in grout).
3. Request evidence in writing of adequate head joint mortar bond to IWR-containing CMU for Properties-based mortars. Request in writing evidence of sufficient composite-action bond to IWR-containing CMU of Properties-based grout.
4. Single wythe walls rely upon a belt-and-suspenders approach to moisture control. Design typically will integrate flashing and weeps, integral water repellent, post-applied moisture control means and measures, sealants, movement joints, damp-checks, crack control, thermal bridging/condensate control, as well as soil elevation offsets and below-grade damp-proofing.

Codes and Standards References

Applicable References are found in Section III.

THE DETAILS PRESENTED IN THIS MANUAL ARE STANDARD DETAILS. DESIGNERS SHOULD MAKE SITE SPECIFIC INVESTIGATIONS TO DETERMINE ACTUAL DESIGN REQUIREMENTS, WHICH MAY VARY.

CPG IS NOT RESPONSIBLE FOR USES OF THIS INFORMATION BY THIRD PARTIES, AND DOES NOT WARRANT THE FITNESS OR SUITABILITY OF THIS INFORMATION FOR ANY PURPOSE. PERSONS MAKING USE OF THIS INFORMATION DO SO AT THEIR OWN RISK.

THESE STANDARD DETAILS ARE MEANT TO ILLUSTRATE GENERAL PRINCIPLES THAT MAY BE HELPFUL, HOWEVER, FINAL DESIGN AND CONSTRUCTION SHOULD BE BASED ON ACTUAL SITE CONDITIONS AND APPLICABLE LOCAL CODE AND STANDARDS. MANY SITE OR LOCAL CONDITIONS MAY REQUIRE SPECIFIC ADDITIONAL DESIGN CONSIDERATIONS. SUCH CONDITIONS MAY INCLUDE SEISMIC ACTIVITY, LOCAL CLIMATE, WIND LOAD AND STORM CONDITIONS (INCLUDING LIKELIHOOD OF TORNADO OR HURRICANE CONDITIONS), SITE SOILS AND DRAINAGE CONSIDERATIONS, AND A VARIETY OF OTHER FACTORS THAT MAY IMPACT BUILDING PERFORMANCE ON A PARTICULAR SITE.



Figure 15. HI-R-H Half High Window Sill

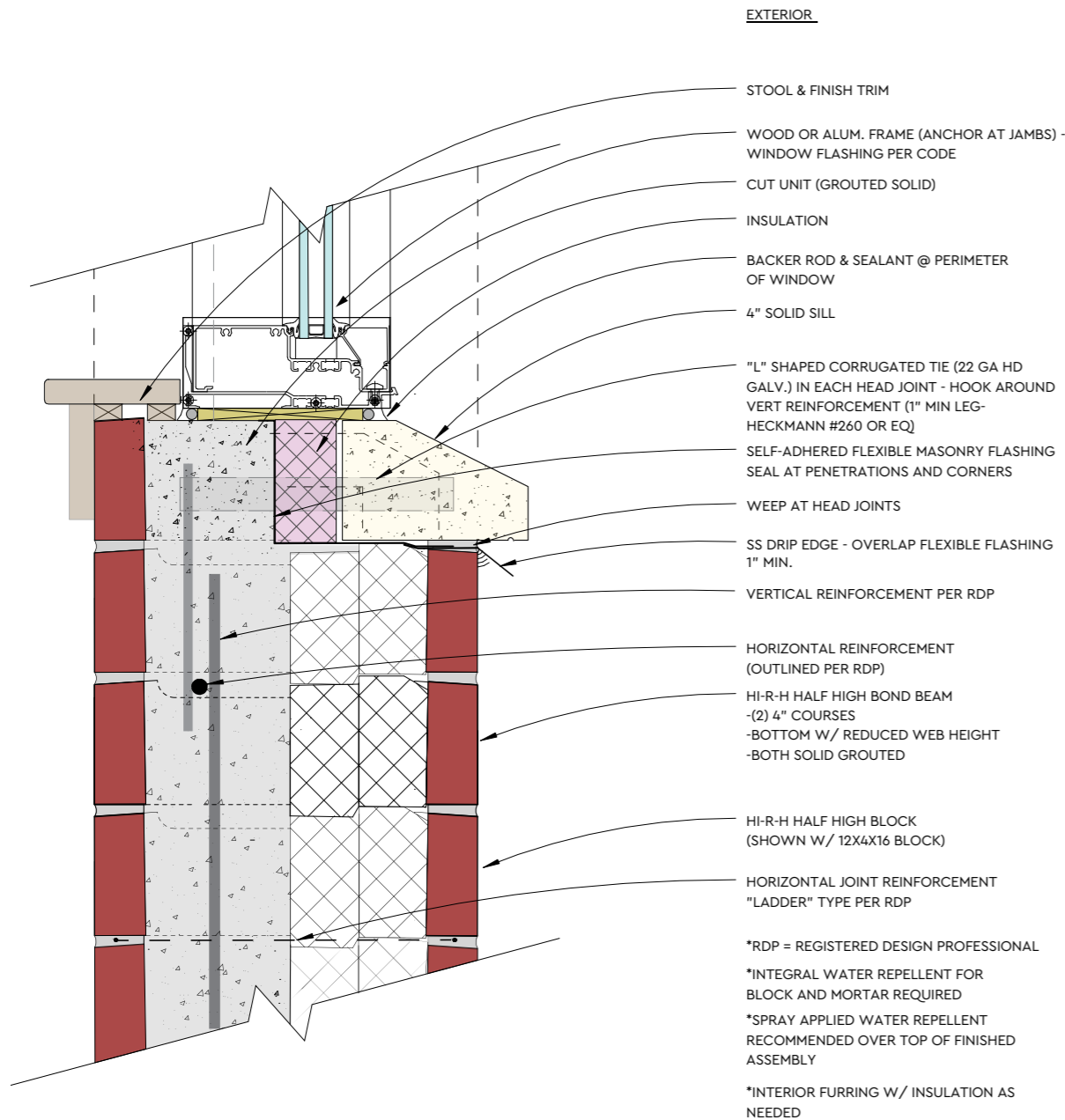

Notes:

1. This detail depicts a fully grouted wall. HI-R walls may be built either fully or partially grouted, while the HI-R-H products are fully grouted only. Fully grouting masonry walls is a cost-effective alternative to partially grouted walls. In many areas of the country where seismic design considerations are important, highly reinforced and fully grouted masonry is the preferred solution. Fully grouted walls do not require flashing at bond beam locations (though flashing at a sill location as shown is recommended), and meet Code air barrier requirements.
2. For projects located in California, or other projects where compliance to vertical wall shear testing is required, alternate moisture control techniques that omit integral water repellent may be used (e.g. use IWR within mortar; use post-applied breathable penetrating sealants or drainable film forming coatings; use High Range Water Reducer in grout).
3. Request evidence in writing of adequate head joint mortar bond to IWR-containing CMU for Properties-based mortars. Request in writing evidence of sufficient composite-action bond to IWR-containing CMU of Properties-based grout.
4. Single wythe walls rely upon a belt-and-suspenders approach to moisture control. Design typically will integrate flashing and weeps, integral water repellent, post-applied moisture control means and measures, sealants, movement joints, damp-checks, crack control, thermal bridging/condensate control, as well as soil elevation offsets and below-grade damp-proofing.

Codes and Standards References

Applicable References are found in Section III.

THE DETAILS PRESENTED IN THIS MANUAL ARE STANDARD DETAILS. DESIGNERS SHOULD MAKE SITE SPECIFIC INVESTIGATIONS TO DETERMINE ACTUAL DESIGN REQUIREMENTS, WHICH MAY VARY.

CPG IS NOT RESPONSIBLE FOR USES OF THIS INFORMATION BY THIRD PARTIES, AND DOES NOT WARRANT THE FITNESS OR SUITABILITY OF THIS INFORMATION FOR ANY PURPOSE. PERSONS MAKING USE OF THIS INFORMATION DO SO AT THEIR OWN RISK.

THESE STANDARD DETAILS ARE MEANT TO ILLUSTRATE GENERAL PRINCIPLES THAT MAY BE HELPFUL, HOWEVER, FINAL DESIGN AND CONSTRUCTION SHOULD BE BASED ON ACTUAL SITE CONDITIONS AND APPLICABLE LOCAL CODE AND STANDARDS. MANY SITE OR LOCAL CONDITIONS MAY REQUIRE SPECIFIC ADDITIONAL DESIGN CONSIDERATIONS. SUCH CONDITIONS MAY INCLUDE SEISMIC ACTIVITY, LOCAL CLIMATE, WIND LOAD AND STORM CONDITIONS (INCLUDING LIKELIHOOD OF TORNADO OR HURRICANE CONDITIONS), SITE SOILS AND DRAINAGE CONSIDERATIONS, AND A VARIETY OF OTHER FACTORS THAT MAY IMPACT BUILDING PERFORMANCE ON A PARTICULAR SITE.



Figure 16. HI-R-H Window Sill

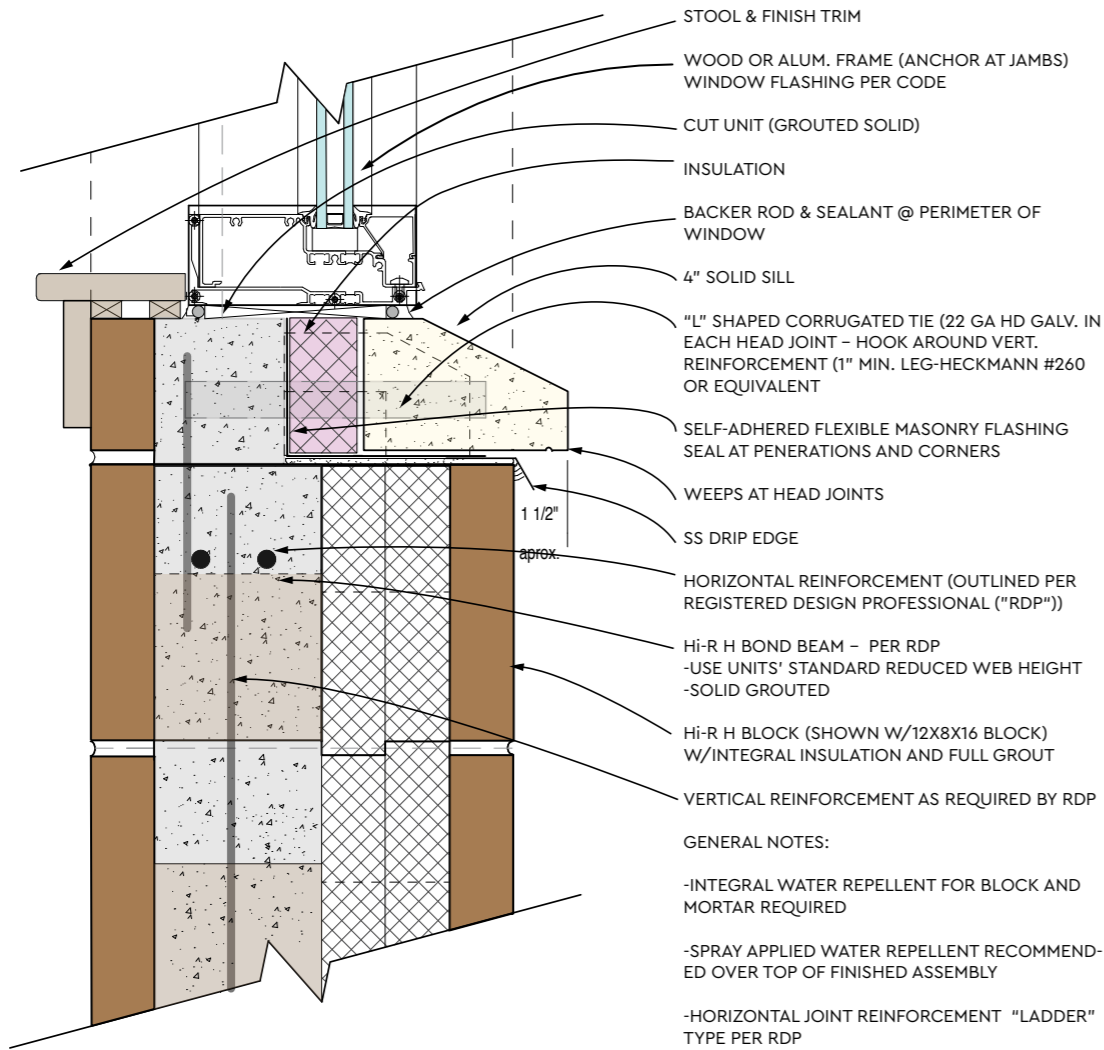

Notes:

1. This detail depicts a fully grouted wall. HI-R walls may be built either fully or partially grouted, while the HI-R-H products are fully grouted only. Fully grouting masonry walls is a cost-effective alternative to partially grouted walls. In many areas of the country where seismic design considerations are important, highly reinforced and fully grouted masonry is the preferred solution. Fully grouted walls do not require flashing at bond beam locations (though flashing at a sill location as shown is recommended), and meet Code air barrier requirements.
2. For projects located in California, or other projects where compliance to vertical wall shear testing is required, alternate moisture control techniques that omit integral water repellent may be used (e.g. use IWR within mortar; use post-applied breathable penetrating sealants or drainable film forming coatings; use High Range Water Reducer in grout).
3. Request evidence in writing of adequate head joint mortar bond to IWR-containing CMU for Properties-based mortars. Request in writing evidence of sufficient composite-action bond to IWR-containing CMU of Properties-based grout.
4. Single wythe walls rely upon a belt-and-suspenders approach to moisture control. Design typically will integrate flashing and weeps, integral water repellent, post-applied moisture control means and measures, sealants, movement joints, damp-checks, crack control, thermal bridging/condensate control, as well as soil elevation offsets and below-grade damp-proofing.

Codes and Standards References

Applicable References are found in Section III.

THE DETAILS PRESENTED IN THIS MANUAL ARE STANDARD DETAILS. DESIGNERS SHOULD MAKE SITE SPECIFIC INVESTIGATIONS TO DETERMINE ACTUAL DESIGN REQUIREMENTS, WHICH MAY VARY.

CPG IS NOT RESPONSIBLE FOR USES OF THIS INFORMATION BY THIRD PARTIES, AND DOES NOT WARRANT THE FITNESS OR SUITABILITY OF THIS INFORMATION FOR ANY PURPOSE. PERSONS MAKING USE OF THIS INFORMATION DO SO AT THEIR OWN RISK.

THESE STANDARD DETAILS ARE MEANT TO ILLUSTRATE GENERAL PRINCIPLES THAT MAY BE HELPFUL, HOWEVER, FINAL DESIGN AND CONSTRUCTION SHOULD BE BASED ON ACTUAL SITE CONDITIONS AND APPLICABLE LOCAL CODE AND STANDARDS. MANY SITE OR LOCAL CONDITIONS MAY REQUIRE SPECIFIC ADDITIONAL DESIGN CONSIDERATIONS. SUCH CONDITIONS MAY INCLUDE SEISMIC ACTIVITY, LOCAL CLIMATE, WIND LOAD AND STORM CONDITIONS (INCLUDING LIKELIHOOD OF TORNADO OR HURRICANE CONDITIONS), SITE SOILS AND DRAINAGE CONSIDERATIONS, AND A VARIETY OF OTHER FACTORS THAT MAY IMPACT BUILDING PERFORMANCE ON A PARTICULAR SITE.



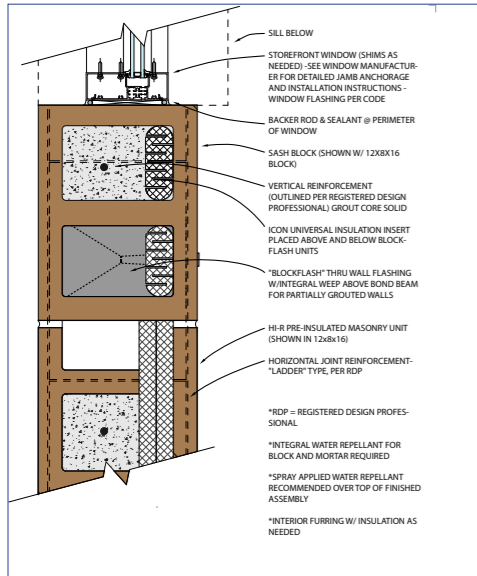

Figure 17. HI-R Window Jamb

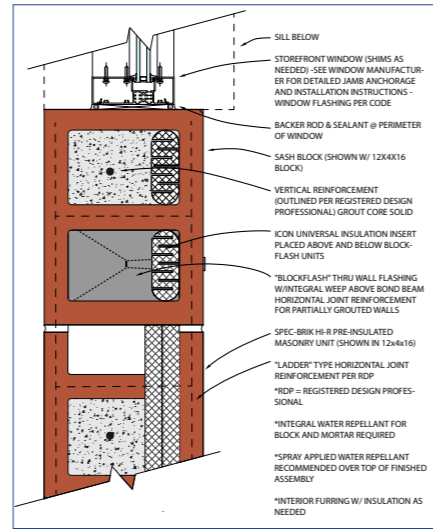

Figure 18. Spec-Brik HI-R Window Jamb

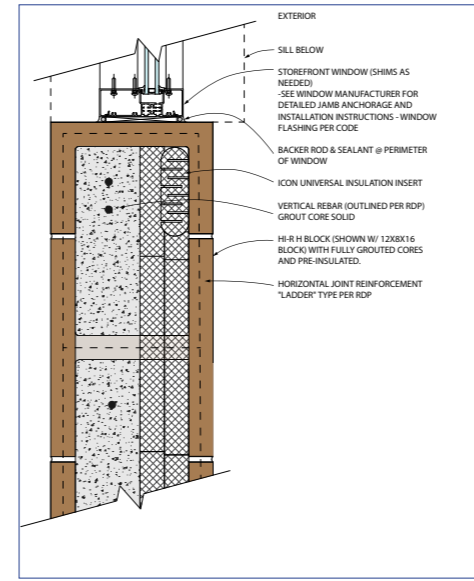

Figure 19. HI-R-H Window Jamb

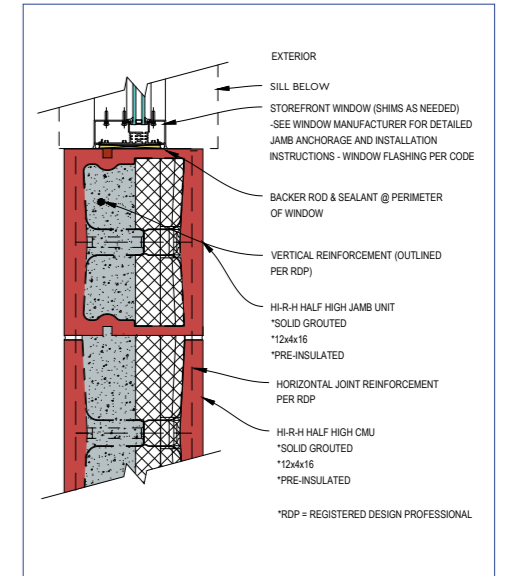

Figure 20. HI-R-H HALF Window Jamb

[Click on drawings to enlarge](#)

Table of Contents	
1	Introduction
2	Window Jamb Details
3	Window Jamb Details
4	Window Jamb Details
5	Window Jamb Details
6	Window Jamb Details
7	Window Jamb Details
8	Window Jamb Details
9	Window Jamb Details
10	Window Jamb Details
11	Window Jamb Details
12	Window Jamb Details
13	Window Jamb Details
14	Window Jamb Details
15	Window Jamb Details
16	Window Jamb Details
17	Window Jamb Details
18	Window Jamb Details
19	Window Jamb Details
20	Window Jamb Details
21	Window Jamb Details
22	Window Jamb Details
23	Window Jamb Details
24	Window Jamb Details
25	Window Jamb Details
26	Window Jamb Details
27	Window Jamb Details
28	Window Jamb Details
29	Window Jamb Details
30	Window Jamb Details
31	Window Jamb Details
32	Window Jamb Details
33	Window Jamb Details
34	Window Jamb Details
35	Window Jamb Details
36	Window Jamb Details
37	Window Jamb Details
38	Window Jamb Details
39	Window Jamb Details
40	Window Jamb Details
41	Window Jamb Details
42	Window Jamb Details
43	Window Jamb Details
44	Window Jamb Details
45	Window Jamb Details
46	Window Jamb Details
47	Window Jamb Details
48	Window Jamb Details
49	Window Jamb Details
50	Window Jamb Details
51	Window Jamb Details
52	Window Jamb Details
53	Window Jamb Details
54	Window Jamb Details
55	Window Jamb Details
56	Window Jamb Details
57	Window Jamb Details
58	Window Jamb Details
59	Window Jamb Details
60	Window Jamb Details
61	Window Jamb Details
62	Window Jamb Details
63	Window Jamb Details
64	Window Jamb Details
65	Window Jamb Details
66	Window Jamb Details
67	Window Jamb Details
68	Window Jamb Details
69	Window Jamb Details
70	Window Jamb Details
71	Window Jamb Details
72	Window Jamb Details
73	Window Jamb Details
74	Window Jamb Details
75	Window Jamb Details
76	Window Jamb Details
77	Window Jamb Details
78	Window Jamb Details
79	Window Jamb Details
80	Window Jamb Details
81	Window Jamb Details
82	Window Jamb Details
83	Window Jamb Details
84	Window Jamb Details
85	Window Jamb Details
86	Window Jamb Details
87	Window Jamb Details
88	Window Jamb Details
89	Window Jamb Details
90	Window Jamb Details
91	Window Jamb Details
92	Window Jamb Details
93	Window Jamb Details
94	Window Jamb Details
95	Window Jamb Details
96	Window Jamb Details
97	Window Jamb Details
98	Window Jamb Details
99	Window Jamb Details
100	Window Jamb Details

Window Jambs

Figure 17. HI-R Window Jamb

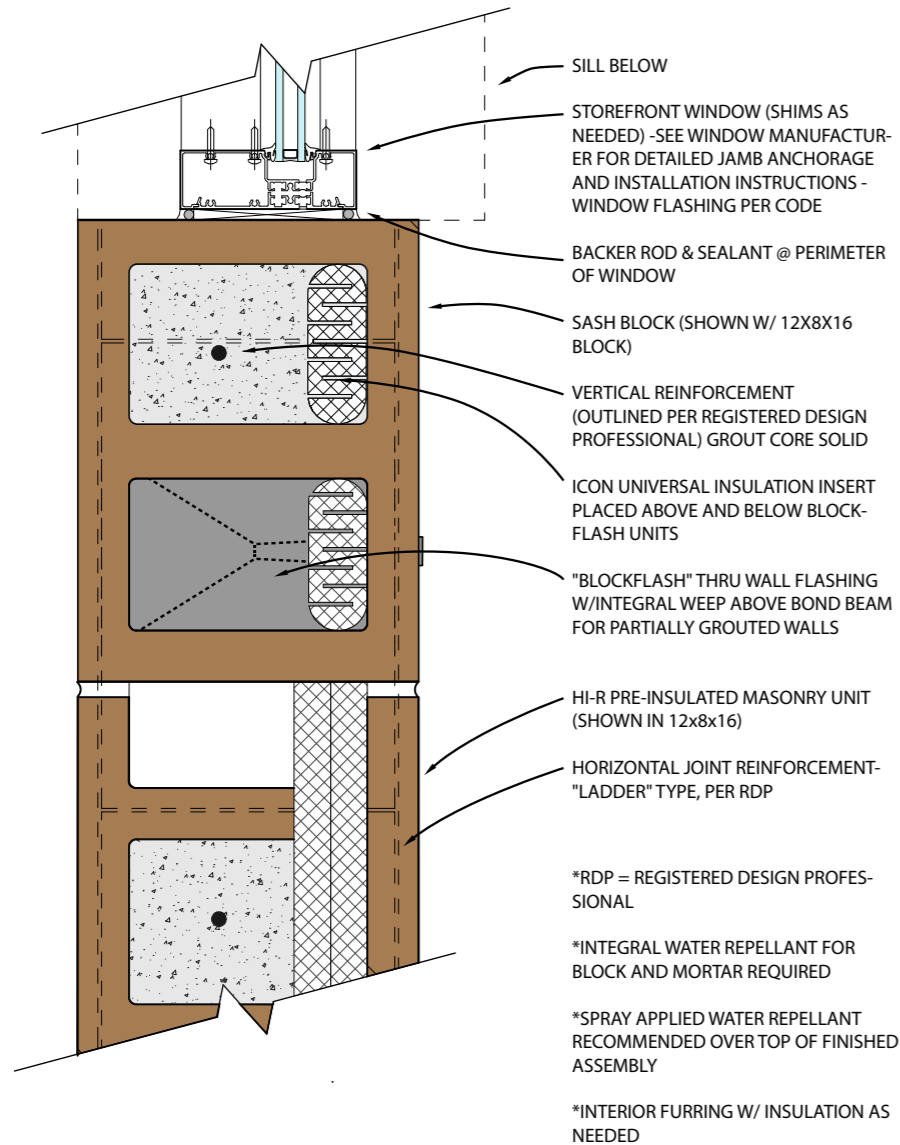

Notes:

1. This detail depicts a partially grouted wall. HI-R walls may be built either fully or partially grouted, while the HI-R-H products are fully grouted only. Fully grouting masonry walls is a cost-effective alternative to partially grouted walls. In many areas of the country where seismic design considerations are important, highly reinforced and fully grouted masonry is the preferred solution. Fully grouted walls do not require flashing at bond beam locations, and meet Code air barrier requirements.
2. For projects located in California, or other projects where compliance to vertical wall shear testing is required, alternate moisture control techniques that omit integral water repellent may be used (e.g. use IWR within mortar; use post-applied breathable penetrating sealants or drainable film forming coatings; use High Range Water Reducer in grout).
3. Request evidence in writing of adequate head joint mortar bond to IWR-containing CMU for Properties-based mortars. Request in writing evidence of sufficient composite-action bond to IWR-containing CMU of Properties-based grout.
4. Single wythe walls rely upon a belt-and-suspenders approach to moisture control. Design typically will integrate flashing and weeps, integral water repellent, post-applied moisture control means and measures, sealants, movement joints, damp-checks, crack control, thermal bridging/condensate control, as well as soil elevation offsets and below-grade damp-proofing.

Codes and Standards References

Applicable References are found in Section III.

THE DETAILS PRESENTED IN THIS MANUAL ARE STANDARD DETAILS. DESIGNERS SHOULD MAKE SITE SPECIFIC INVESTIGATIONS TO DETERMINE ACTUAL DESIGN REQUIREMENTS, WHICH MAY VARY.

CPG IS NOT RESPONSIBLE FOR USES OF THIS INFORMATION BY THIRD PARTIES, AND DOES NOT WARRANT THE FITNESS OR SUITABILITY OF THIS INFORMATION FOR ANY PURPOSE. PERSONS MAKING USE OF THIS INFORMATION DO SO AT THEIR OWN RISK.

THESE STANDARD DETAILS ARE MEANT TO ILLUSTRATE GENERAL PRINCIPLES THAT MAY BE HELPFUL, HOWEVER, FINAL DESIGN AND CONSTRUCTION SHOULD BE BASED ON ACTUAL SITE CONDITIONS AND APPLICABLE CODES AND STANDARDS. MANY SITE OR LOCAL CONDITIONS MAY REQUIRE SPECIFIC ADDITIONAL DESIGN CONSIDERATIONS. SUCH CONDITIONS MAY INCLUDE SEISMIC ACTIVITY, LOCAL CLIMATE, WIND LOAD AND STORM CONDITIONS (INCLUDING LIKELIHOOD OF TORNADO OR HURRICANE CONDITIONS), SITE SOILS AND DRAINAGE CONSIDERATIONS, AND A VARIETY OF OTHER FACTORS THAT MAY IMPACT BUILDING PERFORMANCE ON A PARTICULAR SITE.



Figure 18. Spec-Brik HI-R Window Jamb

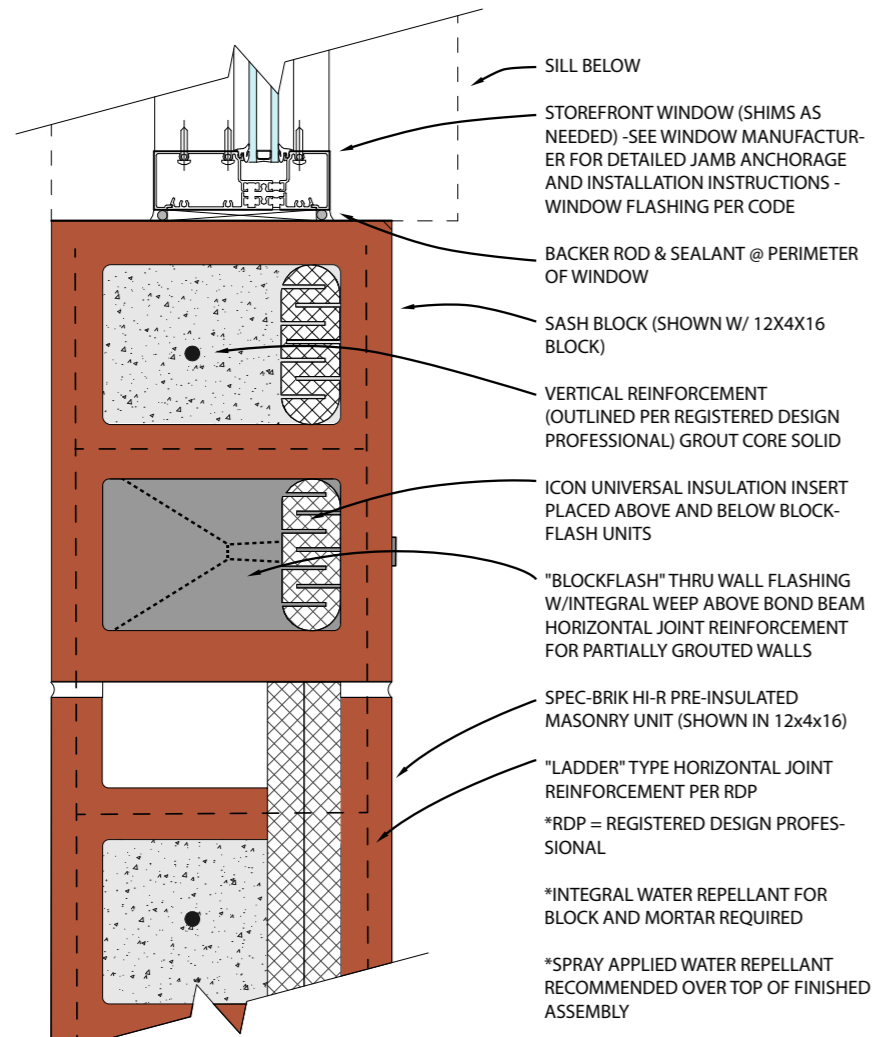

Notes:

1. This detail depicts a partially grouted wall. HI-R walls may be built either fully or partially grouted, while the HI-R-H products are fully grouted only. Fully grouting masonry walls is a cost-effective alternative to partially grouted walls. In many areas of the country where seismic design considerations are important, highly reinforced and fully grouted masonry is the preferred solution. Fully grouted walls do not require flashing at bond beam locations, and meet Code air barrier requirements.
2. For projects located in California, or other projects where compliance to vertical wall shear testing is required, alternate moisture control techniques that omit integral water repellent may be used (e.g. use IWR within mortar; use post-applied breathable penetrating sealants or drainable film forming coatings; use High Range Water Reducer in grout).
3. Request evidence in writing of adequate head joint mortar bond to IWR-containing CMU for Properties-based mortars. Request in writing evidence of sufficient composite-action bond to IWR-containing CMU of Properties-based grout.
4. Single wythe walls rely upon a belt-and-suspenders approach to moisture control. Design typically will integrate flashing and weeps, integral water repellent, post-applied moisture control means and measures, sealants, movement joints, damp-checks, crack control, thermal bridging/condensate control, as well as soil elevation offsets and below-grade damp-proofing.

Codes and Standards References

Applicable References are found in Section III.

THE DETAILS PRESENTED IN THIS MANUAL ARE STANDARD DETAILS. DESIGNERS SHOULD MAKE SITE SPECIFIC INVESTIGATIONS TO DETERMINE ACTUAL DESIGN REQUIREMENTS, WHICH MAY VARY.

CPG IS NOT RESPONSIBLE FOR USES OF THIS INFORMATION BY THIRD PARTIES, AND DOES NOT WARRANT THE FITNESS OR SUITABILITY OF THIS INFORMATION FOR ANY PURPOSE. PERSONS MAKING USE OF THIS INFORMATION DO SO AT THEIR OWN RISK.

THESE STANDARD DETAILS ARE MEANT TO ILLUSTRATE GENERAL PRINCIPLES THAT MAY BE HELPFUL, HOWEVER, FINAL DESIGN AND CONSTRUCTION SHOULD BE BASED ON ACTUAL SITE CONDITIONS AND APPLICABLE CODES AND STANDARDS. MANY SITE OR LOCAL CONDITIONS MAY REQUIRE SPECIFIC ADDITIONAL DESIGN CONSIDERATIONS. SUCH CONDITIONS MAY INCLUDE SEISMIC ACTIVITY, LOCAL CLIMATE, WIND LOAD AND STORM CONDITIONS (INCLUDING LIKELIHOOD OF TORNADO OR HURRICANE CONDITIONS), SITE SOILS AND DRAINAGE CONSIDERATIONS, AND A VARIETY OF OTHER FACTORS THAT MAY IMPACT BUILDING PERFORMANCE ON A PARTICULAR SITE.



Figure 19. HI-R-H Window Jamb

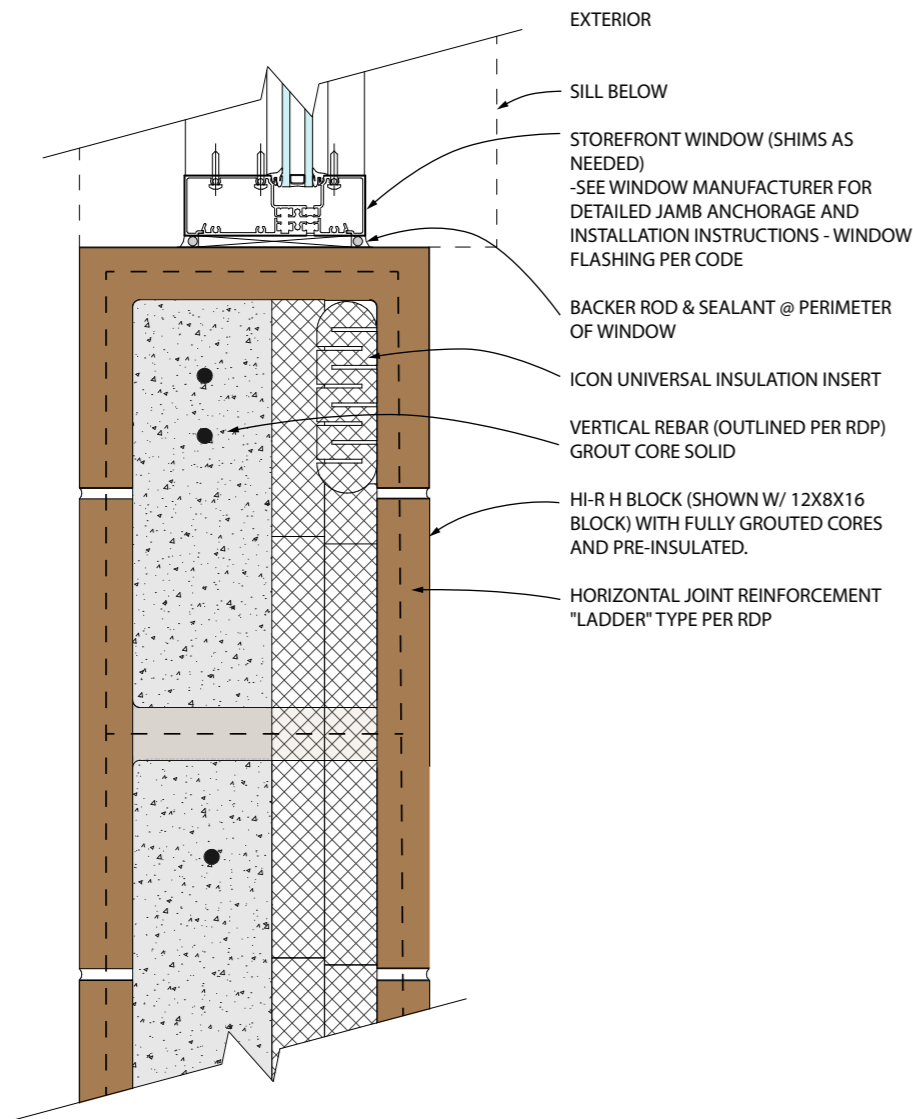

Notes:

1. This detail depicts a fully grouted wall. HI-R walls may be built either fully or partially grouted, while the HI-R-H products are fully grouted only. Fully grouting masonry walls is a cost-effective alternative to partially grouted walls. In many areas of the country where seismic design considerations are important, highly reinforced and fully grouted masonry is the preferred solution. Fully grouted walls do not require flashing at bond beam locations, and meet Code air barrier requirements.
2. For projects located in California, or other projects where compliance to vertical wall shear testing is required, alternate moisture control techniques that omit integral water repellent may be used (e.g. use IWR within mortar; use post-applied breathable penetrating sealants or drainable film forming coatings; use High Range Water Reducer in grout).
3. Request evidence in writing of adequate head joint mortar bond to IWR-containing CMU for Properties-based mortars. Request in writing evidence of sufficient composite-action bond to IWR-containing CMU of Properties-based grout.
4. Single wythe walls rely upon a belt-and-suspenders approach to moisture control. Design typically will integrate flashing and weeps, integral water repellent, post-applied moisture control means and measures, sealants, movement joints, damp-checks, crack control, thermal bridging/condensate control, as well as soil elevation offsets and below-grade damp-proofing.

Codes and Standards References

Applicable References are found in Section III.

THE DETAILS PRESENTED IN THIS MANUAL ARE STANDARD DETAILS. DESIGNERS SHOULD MAKE SITE SPECIFIC INVESTIGATIONS TO DETERMINE ACTUAL DESIGN REQUIREMENTS, WHICH MAY VARY.

CPG IS NOT RESPONSIBLE FOR USES OF THIS INFORMATION BY THIRD PARTIES, AND DOES NOT WARRANT THE FITNESS OR SUITABILITY OF THIS INFORMATION FOR ANY PURPOSE. PERSONS MAKING USE OF THIS INFORMATION DO SO AT THEIR OWN RISK.

THESE STANDARD DETAILS ARE MEANT TO ILLUSTRATE GENERAL PRINCIPLES THAT MAY BE HELPFUL, HOWEVER, FINAL DESIGN AND CONSTRUCTION SHOULD BE BASED ON ACTUAL SITE CONDITIONS AND APPLICABLE CODES AND STANDARDS. MANY SITE OR LOCAL CONDITIONS MAY REQUIRE SPECIFIC ADDITIONAL DESIGN CONSIDERATIONS. SUCH CONDITIONS MAY INCLUDE SEISMIC ACTIVITY, LOCAL CLIMATE, WIND LOAD AND STORM CONDITIONS (INCLUDING LIKELIHOOD OF TORNADO OR HURRICANE CONDITIONS), SITE SOILS AND DRAINAGE CONSIDERATIONS, AND A VARIETY OF OTHER FACTORS THAT MAY IMPACT BUILDING PERFORMANCE ON A PARTICULAR SITE.



Figure 20. Jamb Using HI-R-H or HI-R-H Half High Jamb and Corner Unit

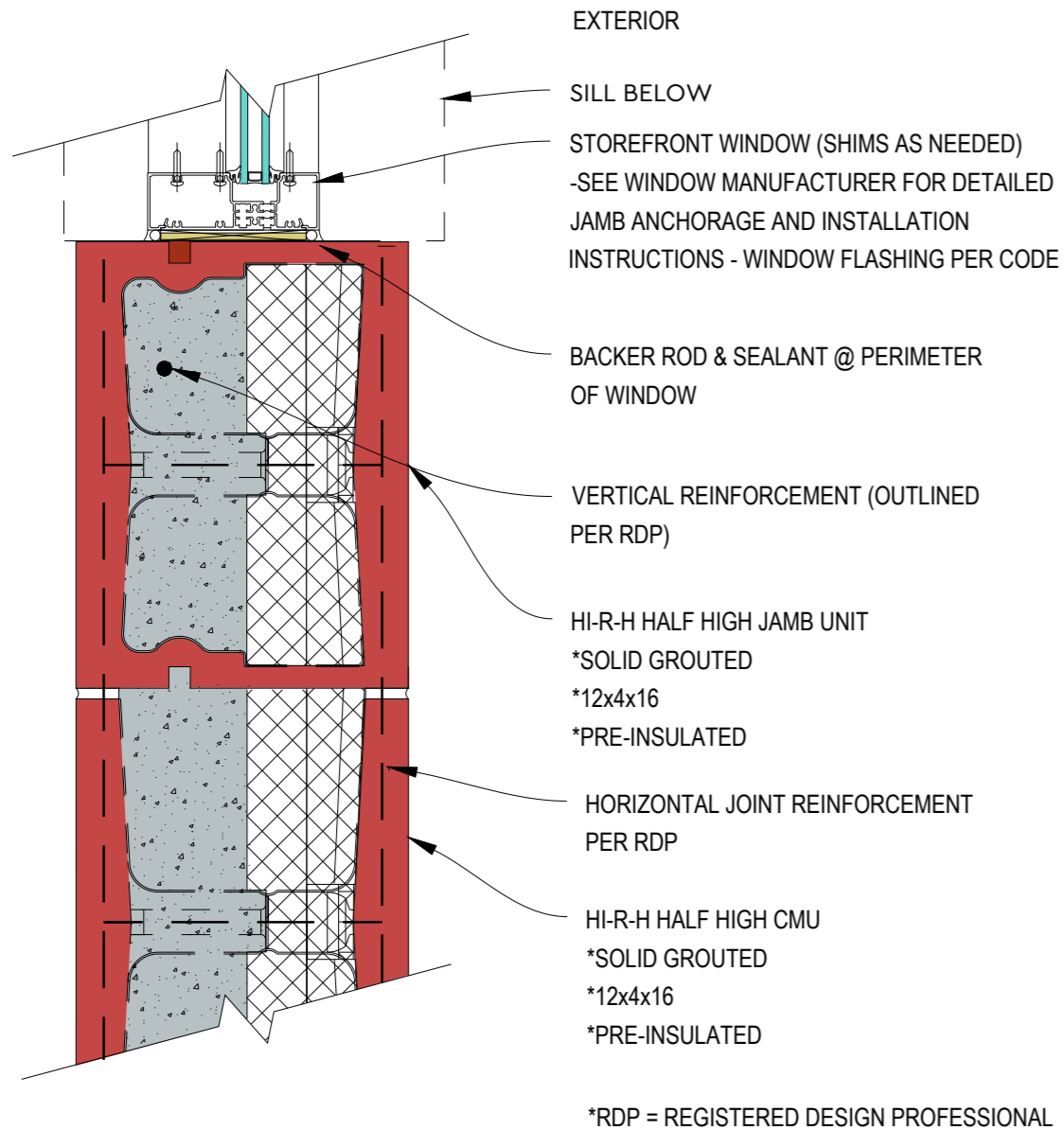

Notes:

1. This Specialty Jamb and Corner unit is only available on a regional basis. Designers should check on local availability prior to specification.
2. This detail depicts a fully grouted wall. HI-R walls may be built either fully or partially grouted, while the HI-R-H products are fully grouted only. Fully grouting masonry walls is a cost-effective alternative to partially grouted walls. In many areas of the country where seismic design considerations are important, highly reinforced and fully grouted masonry is the preferred solution. Fully grouted walls do not require flashing at bond beam locations, and meet Code air barrier requirements.
3. For projects located in California, or other projects where compliance to vertical wall shear testing is required, alternate moisture control techniques that omit integral water repellent may be used (e.g. use IWR within mortar; use post-applied breathable penetrating sealants or drainable film forming coatings; use High Range Water Reducer in grout).
4. Request evidence in writing of adequate head joint mortar bond to IWR-containing CMU for Properties-based mortars. Request in writing evidence of sufficient composite-action bond to IWR-containing CMU of Properties-based grout.
5. Single wythe walls rely upon a belt-and-suspenders approach to moisture control. Design typically will integrate flashing and weeps, integral water repellent, post-applied moisture control means and measures, sealants, movement joints, damp-checks, crack control, thermal bridging/condensate control, as well as soil elevation offsets and below-grade damp-proofing.

THE DETAILS PRESENTED IN THIS MANUAL ARE STANDARD DETAILS. DESIGNERS SHOULD MAKE SITE SPECIFIC INVESTIGATIONS TO DETERMINE ACTUAL DESIGN REQUIREMENTS, WHICH MAY VARY.

CPG IS NOT RESPONSIBLE FOR USES OF THIS INFORMATION BY THIRD PARTIES, AND DOES NOT WARRANT THE FITNESS OR SUITABILITY OF THIS INFORMATION FOR ANY PURPOSE. PERSONS MAKING USE OF THIS INFORMATION DO SO AT THEIR OWN RISK.

THESE STANDARD DETAILS ARE MEANT TO ILLUSTRATE GENERAL PRINCIPLES THAT MAY BE HELPFUL, HOWEVER, FINAL DESIGN AND CONSTRUCTION SHOULD BE BASED ON ACTUAL SITE CONDITIONS AND APPLICABLE CODES AND STANDARDS. MANY SITE OR LOCAL CONDITIONS MAY REQUIRE SPECIFIC ADDITIONAL DESIGN CONSIDERATIONS. SUCH CONDITIONS MAY INCLUDE SEISMIC ACTIVITY, LOCAL CLIMATE, WIND LOAD AND STORM CONDITIONS (INCLUDING LIKELIHOOD OF TORNADO OR HURRICANE CONDITIONS), SITE SOILS AND DRAINAGE CONSIDERATIONS, AND A VARIETY OF OTHER FACTORS THAT MAY IMPACT BUILDING PERFORMANCE ON A PARTICULAR SITE.

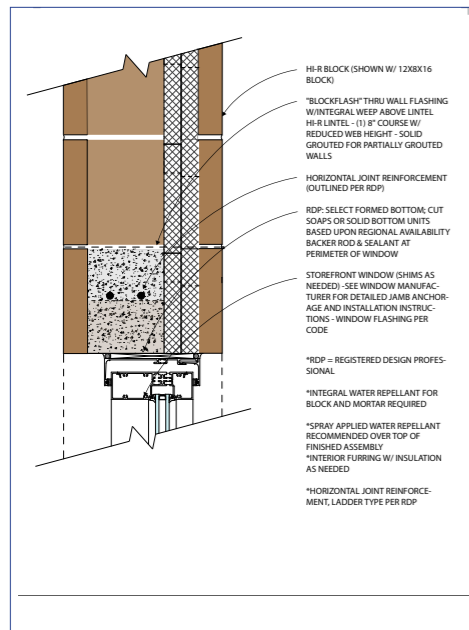

Figure 21. HI-R Lintel

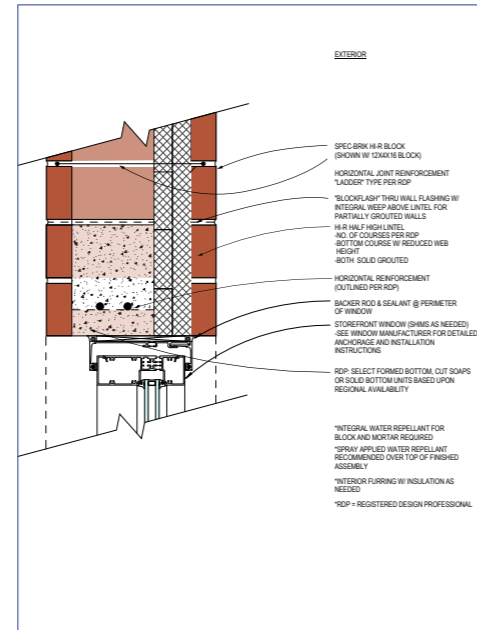

Figure 22. Spec-Brik HI-R Lintel

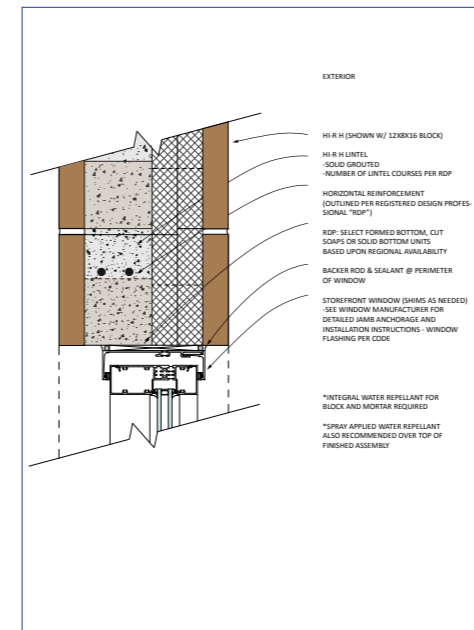

Figure 23. HI-R-H Lintel

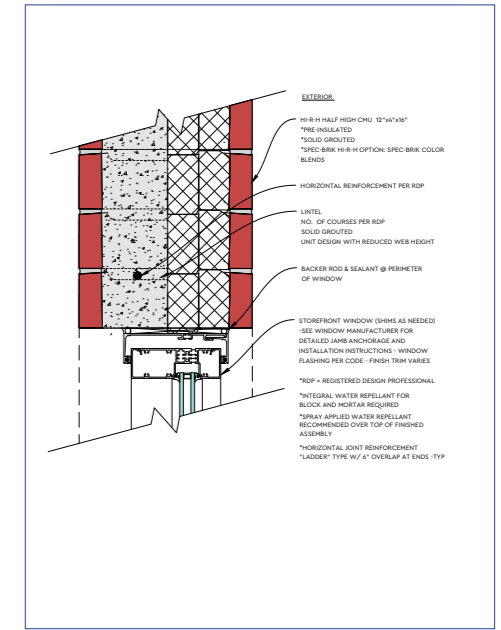

Figure 24. HI-R-H Half High Lintel

Click on drawings to enlarge

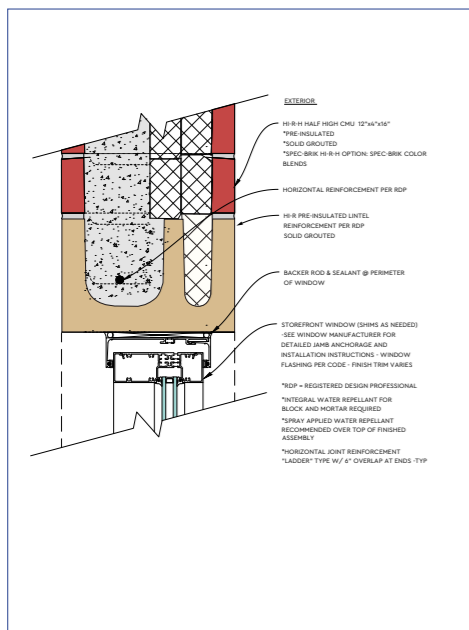
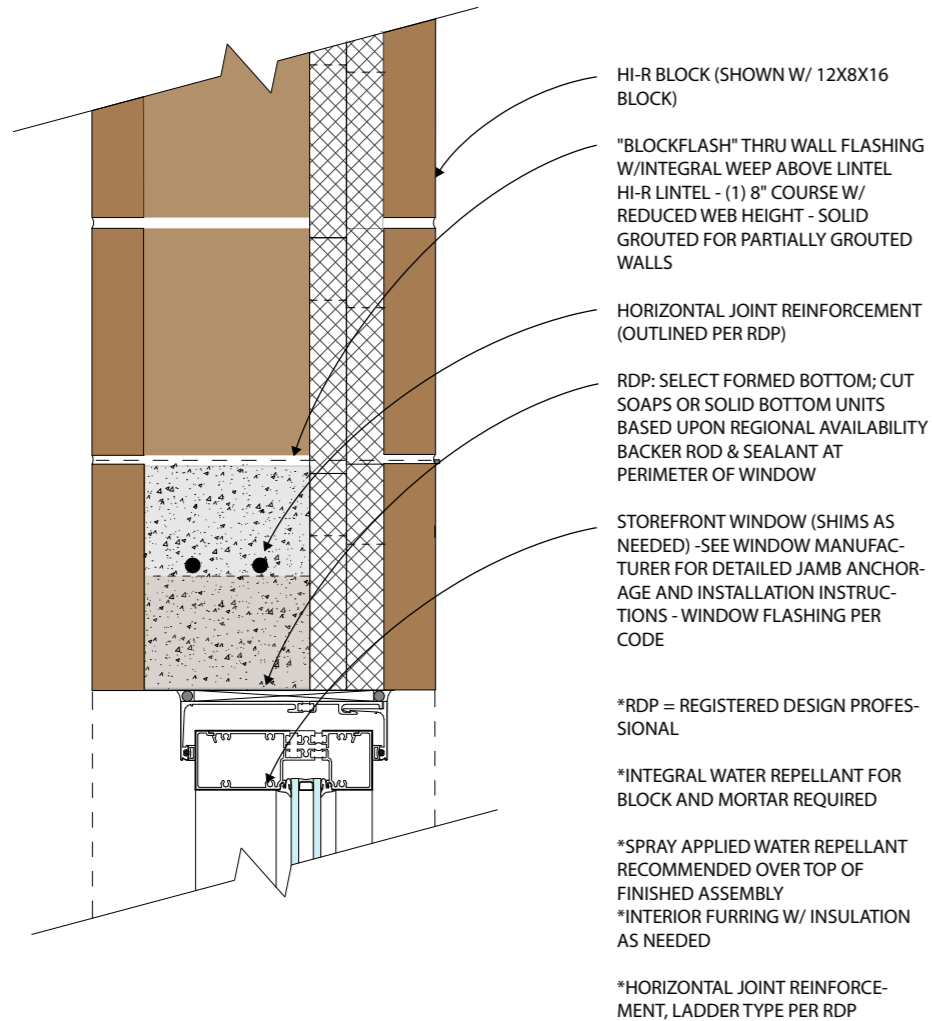

Figure 25. Insulated HI-R Lintel

Table of Contents	
1	Introduction
2	Product Description
3	Installation Instructions
4	Technical Specifications
5	Quality Assurance
6	Warranty
7	Notes
8	Index

Window Head/Lintel

Figure 21. HI-R Lintel



Notes:

1. This detail depicts a partially grouted wall. HI-R walls may be built either fully or partially grouted, while the HI-R-H products are fully grouted only. Fully grouting masonry walls is a cost-effective alternative to partially grouted walls. In many areas of the country where seismic design considerations are important, highly reinforced and fully grouted masonry is the preferred solution. Fully grouted walls do not require flashing at bond beam locations, and meet Code air barrier requirements.
2. For projects located in California, or other projects where compliance to vertical wall shear testing is required, alternate moisture control techniques that omit integral water repellent may be used (e.g. use IWR within mortar; use post-applied breathable penetrating sealants or drainable film forming coatings; use High Range Water Reducer in grout).
3. Request evidence in writing of adequate head joint mortar bond to IWR-containing CMU for Properties-based mortars. Request in writing evidence of sufficient composite-action bond to IWR-containing CMU of Properties-based grout.
4. Single wythe walls rely upon a belt-and-suspenders approach to moisture control. Design typically will integrate flashing and weeps, integral water repellent, post-applied moisture control means and measures, sealants, movement joints, damp-checks, crack control, thermal bridging/condensate control, as well as soil elevation offsets and below-grade damp-proofing.

Codes and Standards References

Applicable References are found in Section III.

THE DETAILS PRESENTED IN THIS MANUAL ARE STANDARD DETAILS. DESIGNERS SHOULD MAKE SITE SPECIFIC INVESTIGATIONS TO DETERMINE ACTUAL DESIGN REQUIREMENTS, WHICH MAY VARY.

CPG IS NOT RESPONSIBLE FOR USES OF THIS INFORMATION BY THIRD PARTIES, AND DOES NOT WARRANT THE FITNESS OR SUITABILITY OF THIS INFORMATION FOR ANY PURPOSE. PERSONS MAKING USE OF THIS INFORMATION DO SO AT THEIR OWN RISK.

THESE STANDARD DETAILS ARE MEANT TO ILLUSTRATE GENERAL PRINCIPLES THAT MAY BE HELPFUL, HOWEVER, FINAL DESIGN AND CONSTRUCTION SHOULD BE BASED ON ACTUAL SITE CONDITIONS AND APPLICABLE CODES AND STANDARDS. MANY SITE OR LOCAL CONDITIONS MAY REQUIRE SPECIFIC ADDITIONAL DESIGN CONSIDERATIONS. SUCH CONDITIONS MAY INCLUDE SEISMIC ACTIVITY, LOCAL CLIMATE, WIND LOAD AND STORM CONDITIONS (INCLUDING LIKELIHOOD OF TORNADO OR HURRICANE CONDITIONS), SITE SOILS AND DRAINAGE CONSIDERATIONS, AND A VARIETY OF OTHER FACTORS THAT MAY IMPACT BUILDING PERFORMANCE ON A PARTICULAR SITE.



Figure 22. Spec-Brik HI-R Lintel

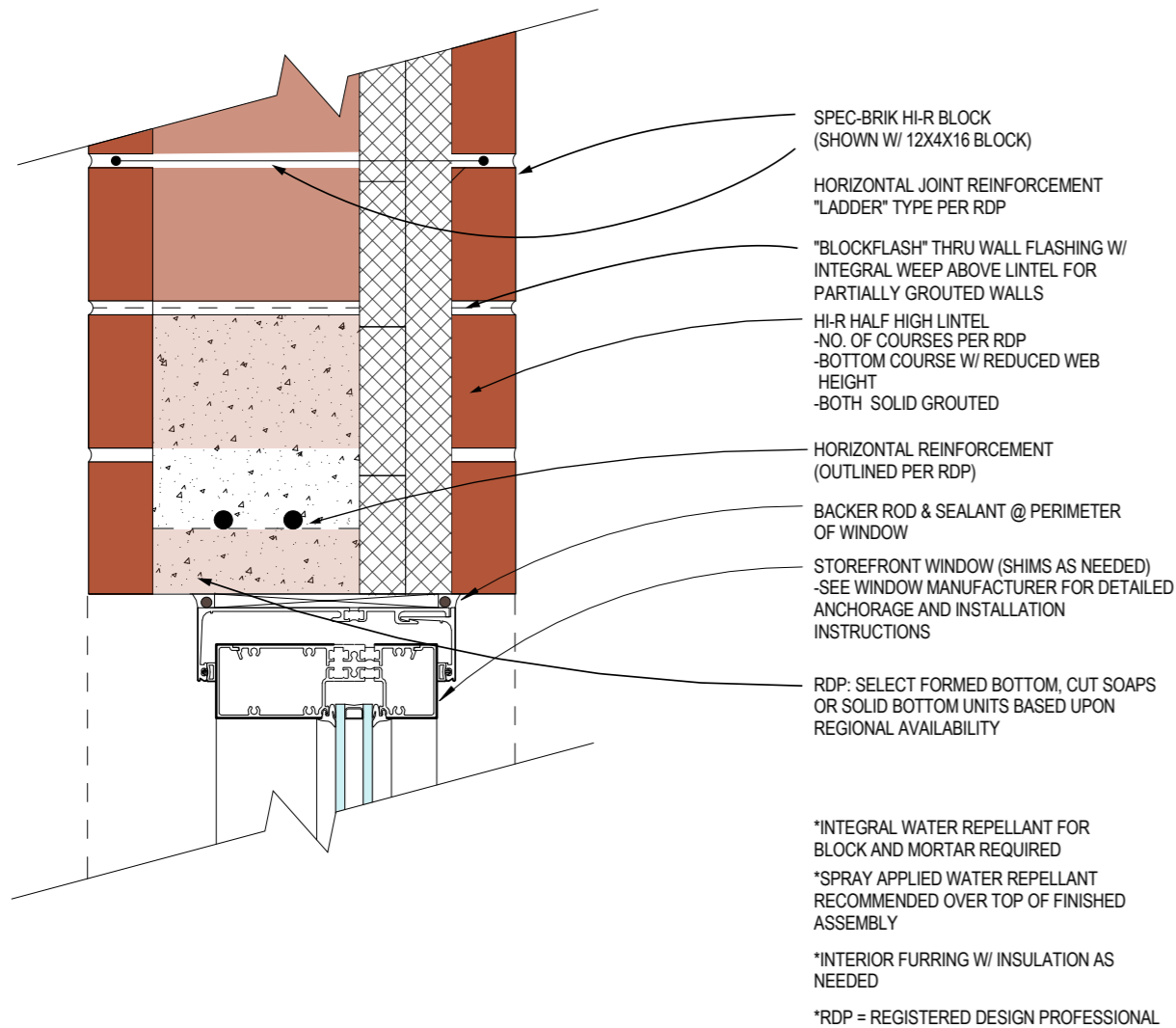

Notes:

1. This detail depicts a partially grouted wall. HI-R walls may be built either fully or partially grouted, while the HI-R-H products are fully grouted only. Fully grouting masonry walls is a cost-effective alternative to partially grouted walls. In many areas of the country where seismic design considerations are important, highly reinforced and fully grouted masonry is the preferred solution. Fully grouted walls do not require flashing at bond beam locations, and meet Code air barrier requirements.
2. For projects located in California, or other projects where compliance to vertical wall shear testing is required, alternate moisture control techniques that omit integral water repellent may be used (e.g. use IWR within mortar; use post-applied breathable penetrating sealants or drainable film forming coatings; use High Range Water Reducer in grout).
3. Request evidence in writing of adequate head joint mortar bond to IWR-containing CMU for Properties-based mortars. Request in writing evidence of sufficient composite-action bond to IWR-containing CMU of Properties-based grout.
4. Single wythe walls rely upon a belt-and-suspenders approach to moisture control. Design typically will integrate flashing and weeps, integral water repellent, post-applied moisture control means and measures, sealants, movement joints, damp-checks, crack control, thermal bridging/condensate control, as well as soil elevation offsets and below-grade damp-proofing.

Codes and Standards References

Applicable References are found in Section III.

THE DETAILS PRESENTED IN THIS MANUAL ARE STANDARD DETAILS. DESIGNERS SHOULD MAKE SITE SPECIFIC INVESTIGATIONS TO DETERMINE ACTUAL DESIGN REQUIREMENTS, WHICH MAY VARY.

CPG IS NOT RESPONSIBLE FOR USES OF THIS INFORMATION BY THIRD PARTIES, AND DOES NOT WARRANT THE FITNESS OR SUITABILITY OF THIS INFORMATION FOR ANY PURPOSE. PERSONS MAKING USE OF THIS INFORMATION DO SO AT THEIR OWN RISK.

THESE STANDARD DETAILS ARE MEANT TO ILLUSTRATE GENERAL PRINCIPLES THAT MAY BE HELPFUL, HOWEVER, FINAL DESIGN AND CONSTRUCTION SHOULD BE BASED ON ACTUAL SITE CONDITIONS AND APPLICABLE CODES AND STANDARDS. MANY SITE OR LOCAL CONDITIONS MAY REQUIRE SPECIFIC ADDITIONAL DESIGN CONSIDERATIONS. SUCH CONDITIONS MAY INCLUDE SEISMIC ACTIVITY, LOCAL CLIMATE, WIND LOAD AND STORM CONDITIONS (INCLUDING LIKELIHOOD OF TORNADO OR HURRICANE CONDITIONS), SITE SOILS AND DRAINAGE CONSIDERATIONS, AND A VARIETY OF OTHER FACTORS THAT MAY IMPACT BUILDING PERFORMANCE ON A PARTICULAR SITE.



Figure 23. HI-R-H Lintel

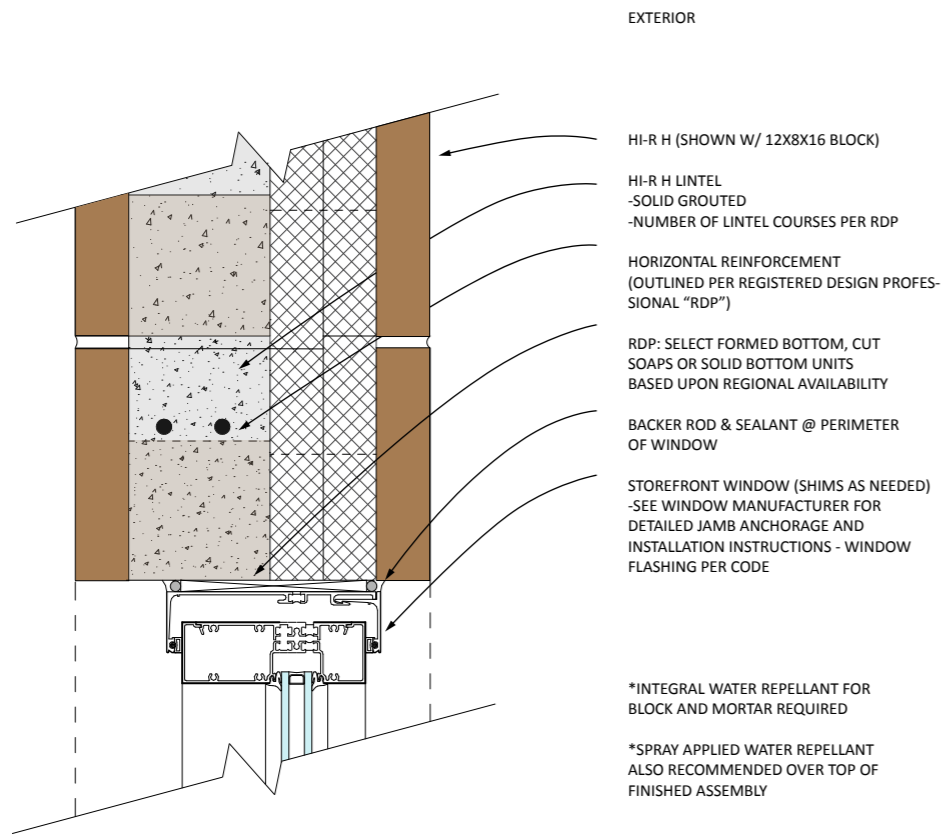

Notes:

1. This detail depicts a fully grouted wall. HI-R walls may be built either fully or partially grouted, while the HI-R-H products are fully grouted only. Fully grouting masonry walls is a cost-effective alternative to partially grouted walls. In many areas of the country where seismic design considerations are important, highly reinforced and fully grouted masonry is the preferred solution. Fully grouted walls do not require flashing at bond beam locations, and meet Code air barrier requirements.
2. For projects located in California, or other projects where compliance to vertical wall shear testing is required, alternate moisture control techniques that omit integral water repellent may be used (e.g. use IWR within mortar; use post-applied breathable penetrating sealants or drainable film forming coatings; use High Range Water Reducer in grout).
3. Request evidence in writing of adequate head joint mortar bond to IWR-containing CMU for Properties-based mortars. Request in writing evidence of sufficient composite-action bond to IWR-containing CMU of Properties-based grout.
4. Single wythe walls rely upon a belt-and-suspenders approach to moisture control. Design typically will integrate flashing and weeps, integral water repellent, post-applied moisture control means and measures, sealants, movement joints, damp-checks, crack control, thermal bridging/condensate control, as well as soil elevation offsets and below-grade damp-proofing.

Codes and Standards References

Applicable References are found in Section III.

THE DETAILS PRESENTED IN THIS MANUAL ARE STANDARD DETAILS. DESIGNERS SHOULD MAKE SITE SPECIFIC INVESTIGATIONS TO DETERMINE ACTUAL DESIGN REQUIREMENTS, WHICH MAY VARY.

CPG IS NOT RESPONSIBLE FOR USES OF THIS INFORMATION BY THIRD PARTIES, AND DOES NOT WARRANT THE FITNESS OR SUITABILITY OF THIS INFORMATION FOR ANY PURPOSE. PERSONS MAKING USE OF THIS INFORMATION DO SO AT THEIR OWN RISK.

THESE STANDARD DETAILS ARE MEANT TO ILLUSTRATE GENERAL PRINCIPLES THAT MAY BE HELPFUL, HOWEVER, FINAL DESIGN AND CONSTRUCTION SHOULD BE BASED ON ACTUAL SITE CONDITIONS AND APPLICABLE CODES AND STANDARDS. MANY SITE OR LOCAL CONDITIONS MAY REQUIRE SPECIFIC ADDITIONAL DESIGN CONSIDERATIONS. SUCH CONDITIONS MAY INCLUDE SEISMIC ACTIVITY, LOCAL CLIMATE, WIND LOAD AND STORM CONDITIONS (INCLUDING LIKELIHOOD OF TORNADO OR HURRICANE CONDITIONS), SITE SOILS AND DRAINAGE CONSIDERATIONS, AND A VARIETY OF OTHER FACTORS THAT MAY IMPACT BUILDING PERFORMANCE ON A PARTICULAR SITE.



Figure 24. HI-R-H Half High Lintel

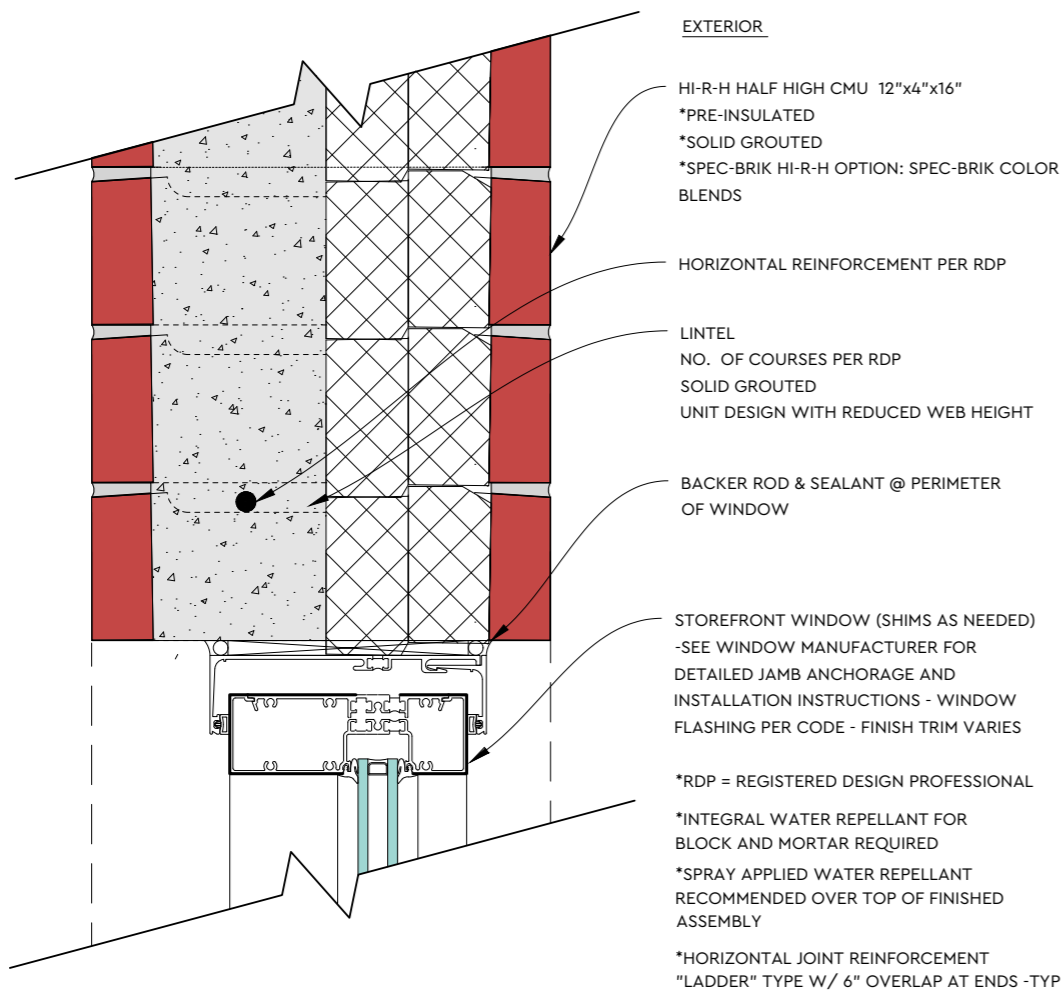

Notes:

1. This detail depicts a fully grouted wall. HI-R walls may be built either fully or partially grouted, while the HI-R-H products are fully grouted only. Fully grouting masonry walls is a cost-effective alternative to partially grouted walls. In many areas of the country where seismic design considerations are important, highly reinforced and fully grouted masonry is the preferred solution. Fully grouted walls do not require flashing at bond beam locations, and meet Code air barrier requirements.
2. For projects located in California, or other projects where compliance to vertical wall shear testing is required, alternate moisture control techniques that omit integral water repellent may be used (e.g. use IWR within mortar; use post-applied breathable penetrating sealants or drainable film forming coatings; use High Range Water Reducer in grout).
3. Request evidence in writing of adequate head joint mortar bond to IWR-containing CMU for Properties-based mortars. Request in writing evidence of sufficient composite-action bond to IWR-containing CMU of Properties-based grout.
4. Single wythe walls rely upon a belt-and-suspenders approach to moisture control. Design typically will integrate flashing and weeps, integral water repellent, post-applied moisture control means and measures, sealants, movement joints, damp-checks, crack control, thermal bridging/condensate control, as well as soil elevation offsets and below-grade damp-proofing.

Codes and Standards References

Applicable References are found in Section III.

THE DETAILS PRESENTED IN THIS MANUAL ARE STANDARD DETAILS. DESIGNERS SHOULD MAKE SITE SPECIFIC INVESTIGATIONS TO DETERMINE ACTUAL DESIGN REQUIREMENTS, WHICH MAY VARY.

CPG IS NOT RESPONSIBLE FOR USES OF THIS INFORMATION BY THIRD PARTIES, AND DOES NOT WARRANT THE FITNESS OR SUITABILITY OF THIS INFORMATION FOR ANY PURPOSE. PERSONS MAKING USE OF THIS INFORMATION DO SO AT THEIR OWN RISK.

THESE STANDARD DETAILS ARE MEANT TO ILLUSTRATE GENERAL PRINCIPLES THAT MAY BE HELPFUL, HOWEVER, FINAL DESIGN AND CONSTRUCTION SHOULD BE BASED ON ACTUAL SITE CONDITIONS AND APPLICABLE CODES AND STANDARDS. MANY SITE OR LOCAL CONDITIONS MAY REQUIRE SPECIFIC ADDITIONAL DESIGN CONSIDERATIONS. SUCH CONDITIONS MAY INCLUDE SEISMIC ACTIVITY, LOCAL CLIMATE, WIND LOAD AND STORM CONDITIONS (INCLUDING LIKELIHOOD OF TORNADO OR HURRICANE CONDITIONS), SITE SOILS AND DRAINAGE CONSIDERATIONS, AND A VARIETY OF OTHER FACTORS THAT MAY IMPACT BUILDING PERFORMANCE ON A PARTICULAR SITE.

Figure 25. HI-R Pre-Insulated Lintel Unit

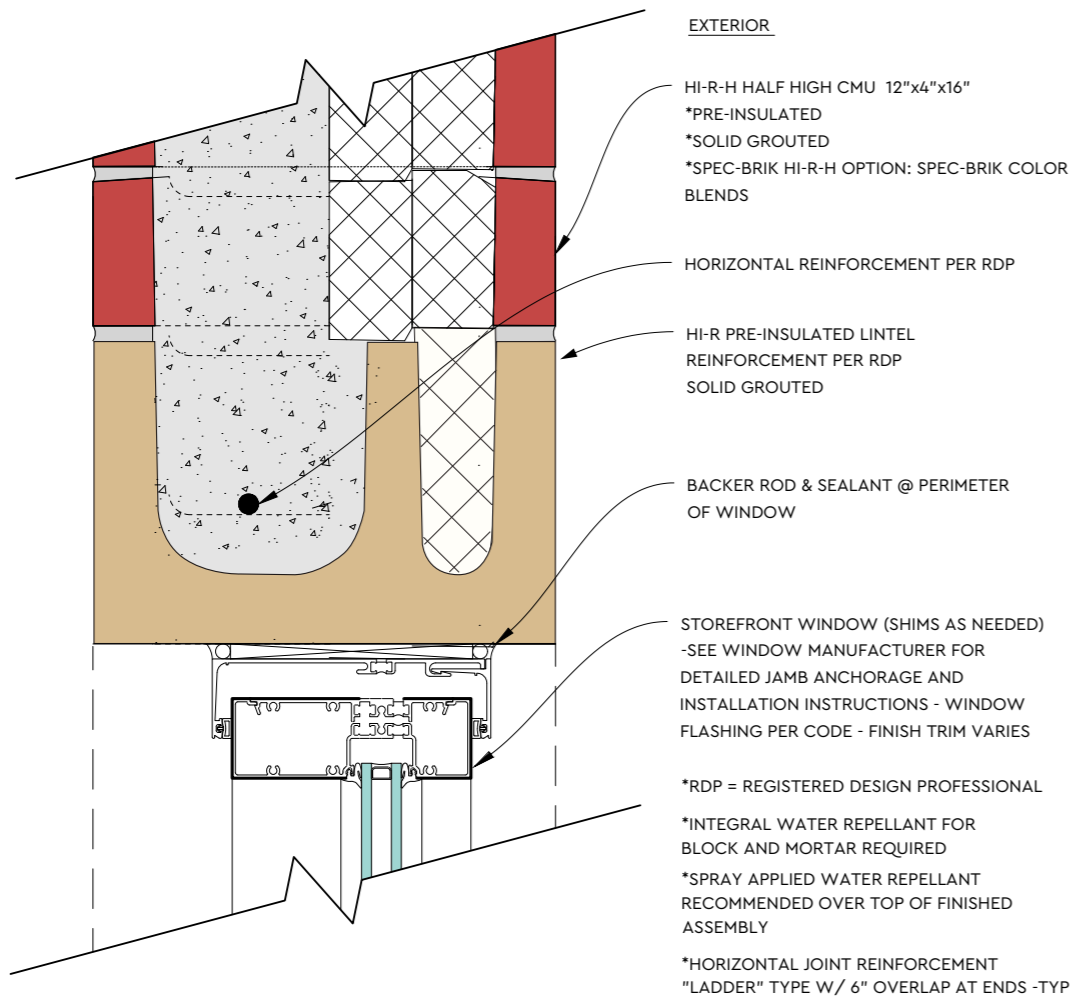

Notes:

1. This specialty Lintel unit is available regionally- please check with your local supplier for availability. The HI-R Lintel unit is compatible with all HI-R and HI-R-H product types.
2. For projects located in California, or other projects where compliance to vertical wall shear testing is required, alternate moisture control techniques that omit integral water repellent may be used (e.g. use IWR within mortar; use post-applied breathable penetrating sealants or drainable film forming coatings; use High Range Water Reducer in grout).
3. Request evidence in writing of adequate head joint mortar bond to IWR-containing CMU for Properties-based mortars. Request in writing evidence of sufficient composite-action bond to IWR-containing CMU of Properties-based grout.
4. Single wythe walls rely upon a belt-and-suspenders approach to moisture control. Design typically will integrate flashing and weeps, integral water repellent, post-applied moisture control means and measures, sealants, movement joints, damp-checks, crack control, thermal bridging/condensate control, as well as soil elevation offsets and below-grade damp-proofing.

Codes and Standards References

Applicable References are found in Section III.

THE DETAILS PRESENTED IN THIS MANUAL ARE STANDARD DETAILS. DESIGNERS SHOULD MAKE SITE SPECIFIC INVESTIGATIONS TO DETERMINE ACTUAL DESIGN REQUIREMENTS, WHICH MAY VARY.

CPG IS NOT RESPONSIBLE FOR USES OF THIS INFORMATION BY THIRD PARTIES, AND DOES NOT WARRANT THE FITNESS OR SUITABILITY OF THIS INFORMATION FOR ANY PURPOSE. PERSONS MAKING USE OF THIS INFORMATION DO SO AT THEIR OWN RISK.

THESE STANDARD DETAILS ARE MEANT TO ILLUSTRATE GENERAL PRINCIPLES THAT MAY BE HELPFUL, HOWEVER, FINAL DESIGN AND CONSTRUCTION SHOULD BE BASED ON ACTUAL SITE CONDITIONS AND APPLICABLE CODES AND STANDARDS. MANY SITE OR LOCAL CONDITIONS MAY REQUIRE SPECIFIC ADDITIONAL DESIGN CONSIDERATIONS. SUCH CONDITIONS MAY INCLUDE SEISMIC ACTIVITY, LOCAL CLIMATE, WIND LOAD AND STORM CONDITIONS (INCLUDING LIKELIHOOD OF TORNADO OR HURRICANE CONDITIONS), SITE SOILS AND DRAINAGE CONSIDERATIONS, AND A VARIETY OF OTHER FACTORS THAT MAY IMPACT BUILDING PERFORMANCE ON A PARTICULAR SITE.

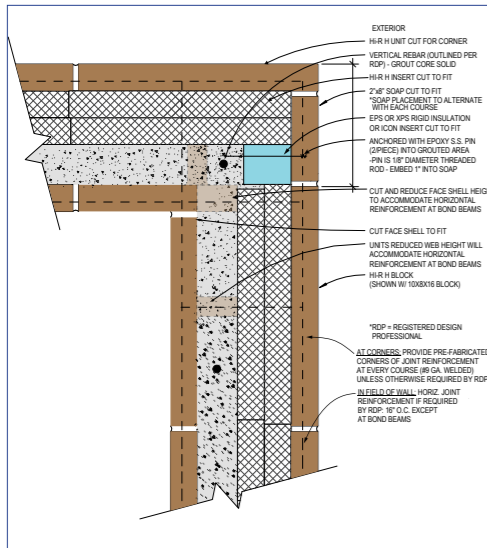

Figure 26. 10" HI-R-H Corner-Ext. Soap

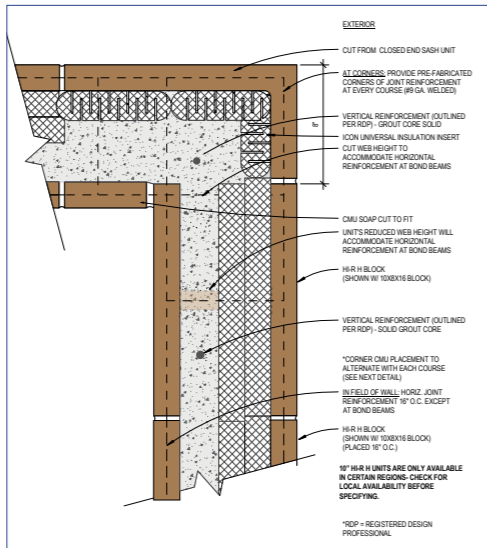

Figure 27. 10" HI-R-H Corner-L-Veneer Course 1

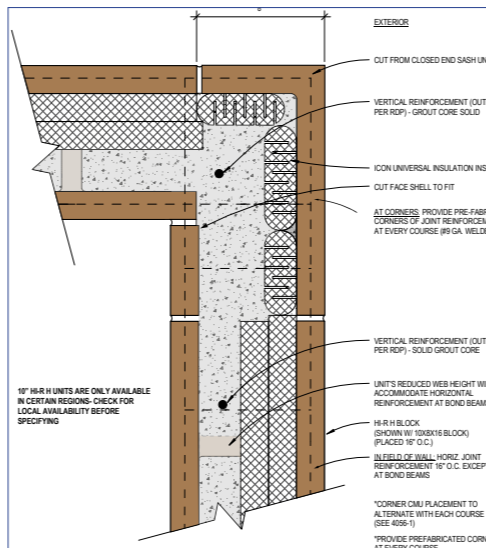

Figure 28. 10" HI-R-H Corner-L-Veneer Course 2

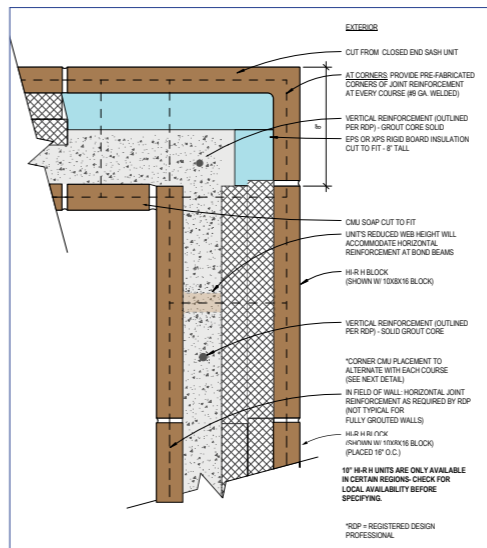

Figure 29. 10" HI-R-H Corner-L-Veneer Course 1

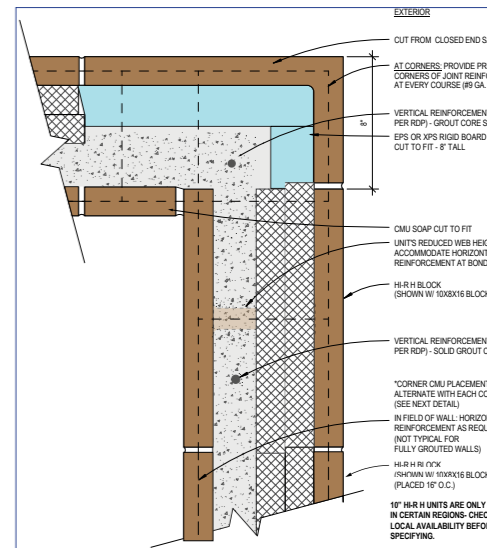

Figure 30. 10" HI-R-H Corner-L-Veneer Course 2

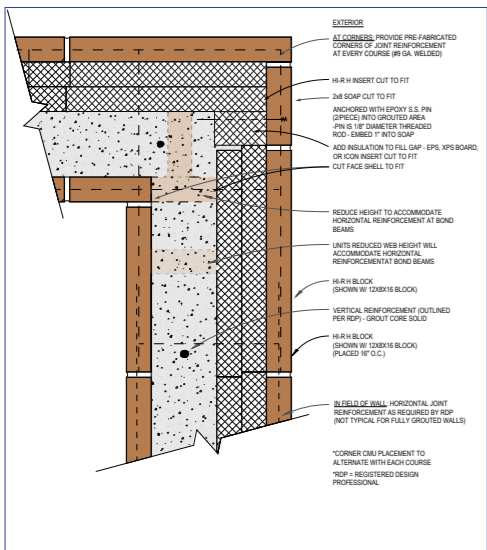

Figure 31. 12" HI-R-H Corner-Ext. Soap

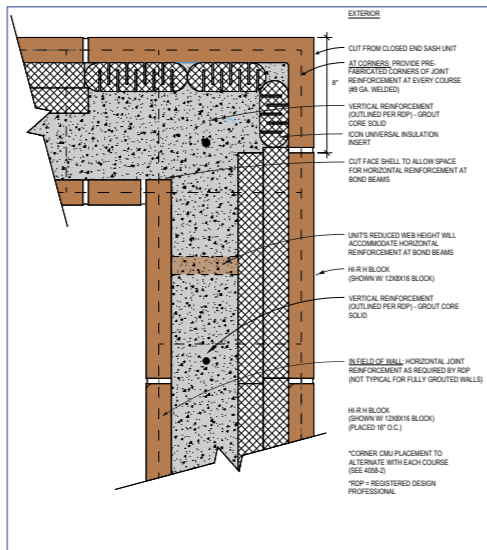

Figure 32. 12" HI-R-H Corner L Veneer Course 1

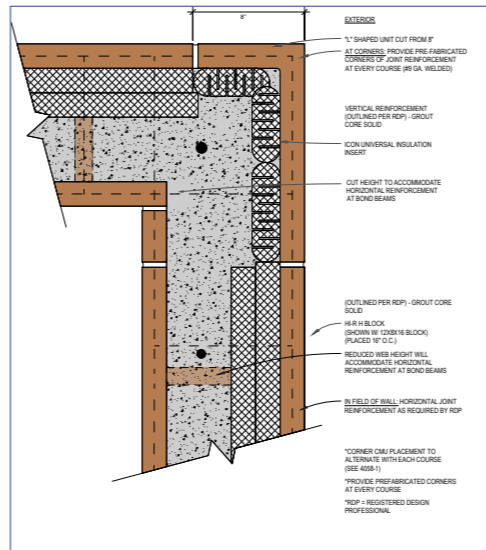

Figure 33. 12" HI-R-H Corner L Veneer Course 2

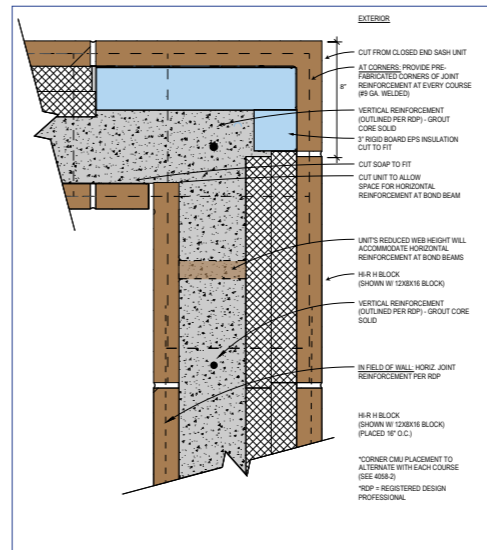

Figure 34. 12" HI-R-H Corner L Veneer Course 1

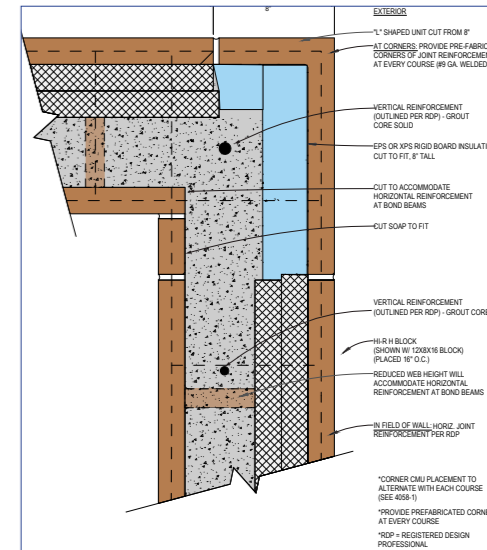

Figure 35. 12" HI-R-H Corner L Veneer Course 2

Click on drawings to enlarge

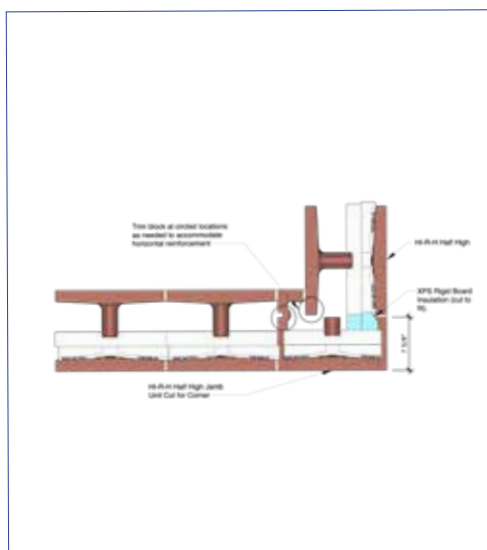
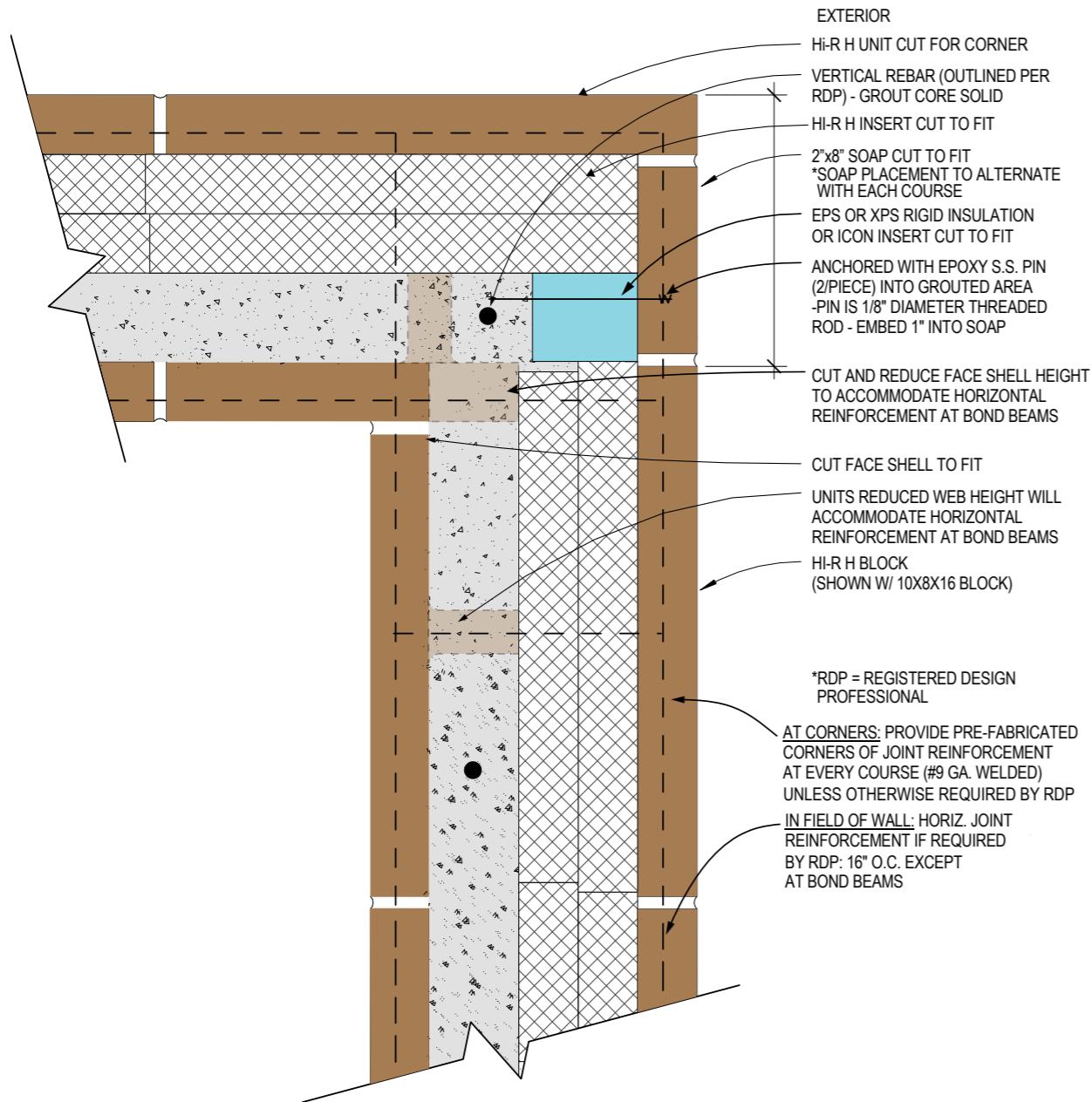

Figure 36. 12" HI-R-H HALF HIGH WITH JAMB/CORNER UNIT

Table of Contents	
1	Introduction
2	Product Description
3	Installation
4	Finishing
5	Quality Control
6	Warranty
7	Index

HI-R-H Corners

Figure 26. 10" HI-R-H Bonded Corner – Exterior Soap



Notes:

1. The 10" version of HI-R-H is limited to regional availability. Please check with your local manufacturer prior to specification.
2. This detail illustrates how to build bonded corners with HI-R-H that meet structural requirements while maintaining insulation at the corner locations. This detail uses an exterior soap and cuts to the HI-R-H Units to form the corner. While this approach requires cutting both HI-R Units, the only separate fitting required for the corner is the soap.
3. Avoid bonded corners to save cost and time of construction. Not all designs require a bonded corner.
4. HI-R-H units can serve both as stretcher and bond beam unit without any modification. The reduced web height accommodates horizontal rebar. They are designed for construction of fully grouted and reinforced walls because they can be placed at rebar locations without the need to lift the unit over the top of the rebar as would be necessary with a more traditional CMU design, and grout will flow laterally at every course due to the reduced web heights.
5. HI-R-H units can also combine readily with conventional masonry fittings for construction of a variety of wall assembly details, including corners, joints, ends, and sills.

Codes and Standards References

Applicable References are found in Section III.

THE DETAILS PRESENTED IN THIS MANUAL ARE STANDARD DETAILS. DESIGNERS SHOULD MAKE SITE SPECIFIC INVESTIGATIONS TO DETERMINE ACTUAL DESIGN REQUIREMENTS, WHICH MAY VARY.

CPG IS NOT RESPONSIBLE FOR USES OF THIS INFORMATION BY THIRD PARTIES, AND DOES NOT WARRANT THE FITNESS OR SUITABILITY OF THIS INFORMATION FOR ANY PURPOSE. PERSONS MAKING USE OF THIS INFORMATION DO SO AT THEIR OWN RISK.

THESE STANDARD DETAILS ARE MEANT TO ILLUSTRATE GENERAL PRINCIPLES THAT MAY BE HELPFUL, HOWEVER, FINAL DESIGN AND CONSTRUCTION SHOULD BE BASED ON ACTUAL SITE CONDITIONS AND APPLICABLE LOCAL CODE AND STANDARDS. MANY SITE OR LOCAL CONDITIONS MAY REQUIRE SPECIFIC ADDITIONAL DESIGN CONSIDERATIONS. SUCH CONDITIONS MAY INCLUDE SEISMIC ACTIVITY, LOCAL CLIMATE, WIND LOAD AND STORM CONDITIONS (INCLUDING LIKELIHOOD OF TORNADO OR HURRICANE CONDITIONS), SITE SOILS AND DRAINAGE CONSIDERATIONS, AND A VARIETY OF OTHER FACTORS THAT MAY IMPACT BUILDING PERFORMANCE ON A PARTICULAR SITE.



Figure 27. 10" HI-R-H Bonded Corner. L-Shape Veneer – course 1

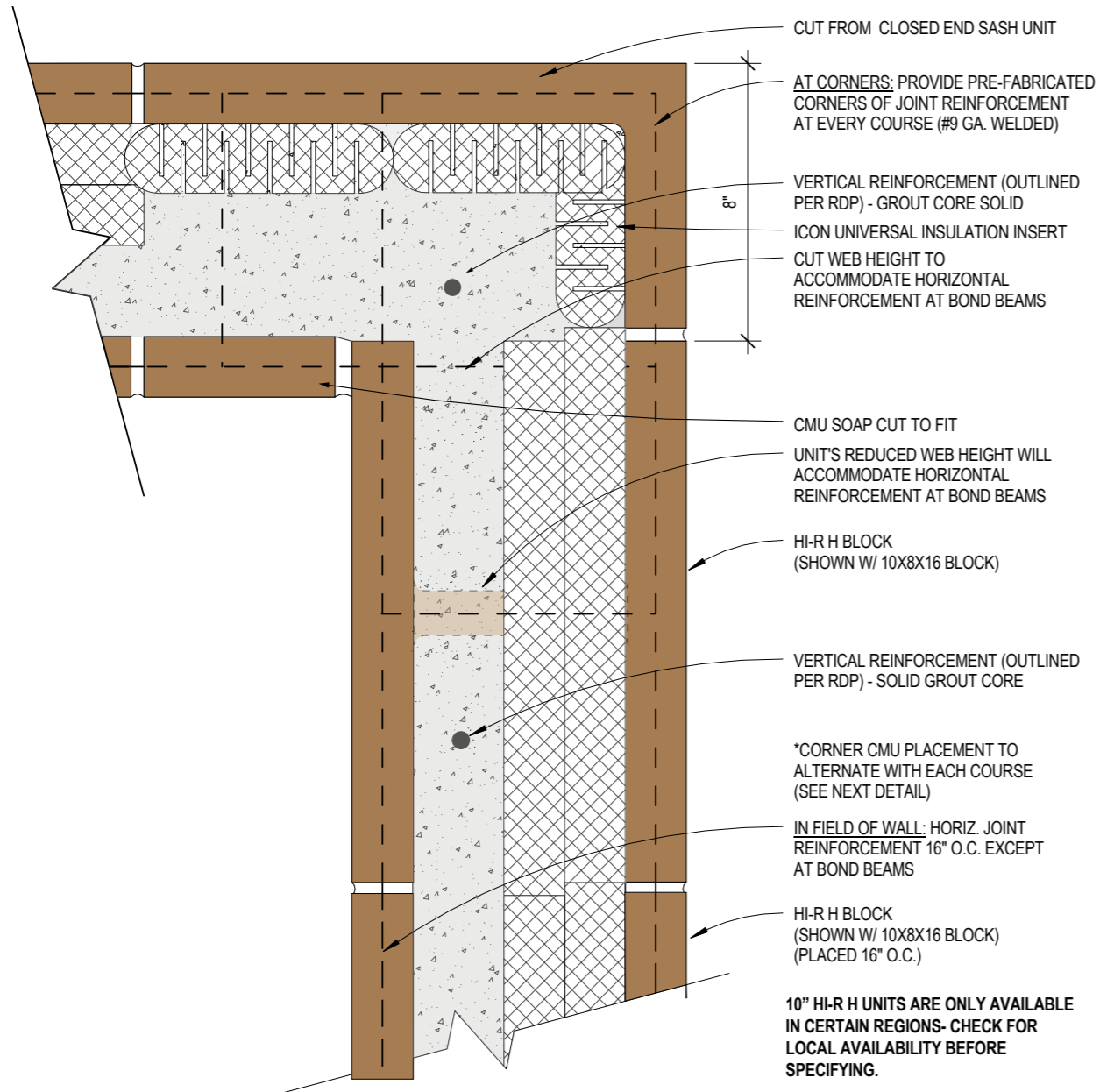

10" HI-R H UNITS ARE ONLY AVAILABLE IN CERTAIN REGIONS- CHECK FOR LOCAL AVAILABILITY BEFORE SPECIFYING.

Notes:

1. The 10" version of HI-R-H is limited to regional availability. Please check with your local manufacturer prior to specification.
2. This detail illustrates how to build bonded corners with HI-R-H that meet structural requirements while maintaining insulation at the corner locations. This detail uses an exterior soap and cuts to the HI-R-H Units to form the corner. While this approach requires cutting both HI-R Units, the only separate fitting required for the corner is the soap.
3. Avoid bonded corners to save cost and time of construction. Not all designs require a bonded corner.
4. HI-R-H units can serve both as stretcher and bond beam unit without any modification. The reduced web height accommodates horizontal rebar. They are designed for construction of fully grouted and reinforced walls because they can be placed at rebar locations without the need to lift the unit over the top of the rebar as would be necessary with a more traditional CMU design, and grout will flow laterally at every course due to the reduced web heights.
5. HI-R-H units can also combine readily with conventional masonry fittings for construction of a variety of wall assembly details, including corners, joints, ends, and sills.

Codes and Standards References

Applicable References are found in Section III.

THE DETAILS PRESENTED IN THIS MANUAL ARE STANDARD DETAILS. DESIGNERS SHOULD MAKE SITE SPECIFIC INVESTIGATIONS TO DETERMINE ACTUAL DESIGN REQUIREMENTS, WHICH MAY VARY.

CPG IS NOT RESPONSIBLE FOR USES OF THIS INFORMATION BY THIRD PARTIES, AND DOES NOT WARRANT THE FITNESS OR SUITABILITY OF THIS INFORMATION FOR ANY PURPOSE. PERSONS MAKING USE OF THIS INFORMATION DO SO AT THEIR OWN RISK.

THESE STANDARD DETAILS ARE MEANT TO ILLUSTRATE GENERAL PRINCIPLES THAT MAY BE HELPFUL, HOWEVER, FINAL DESIGN AND CONSTRUCTION SHOULD BE BASED ON ACTUAL SITE CONDITIONS AND APPLICABLE LOCAL CODE AND STANDARDS. MANY SITE OR LOCAL CONDITIONS MAY REQUIRE SPECIFIC ADDITIONAL DESIGN CONSIDERATIONS. SUCH CONDITIONS MAY INCLUDE SEISMIC ACTIVITY, LOCAL CLIMATE, WIND LOAD AND STORM CONDITIONS (INCLUDING LIKELIHOOD OF TORNADO OR HURRICANE CONDITIONS), SITE SOILS AND DRAINAGE CONSIDERATIONS, AND A VARIETY OF OTHER FACTORS THAT MAY IMPACT BUILDING PERFORMANCE ON A PARTICULAR SITE.



Figure 28. 10" HI-R-H Bonded Corner. L-Shape Veneer - course 2

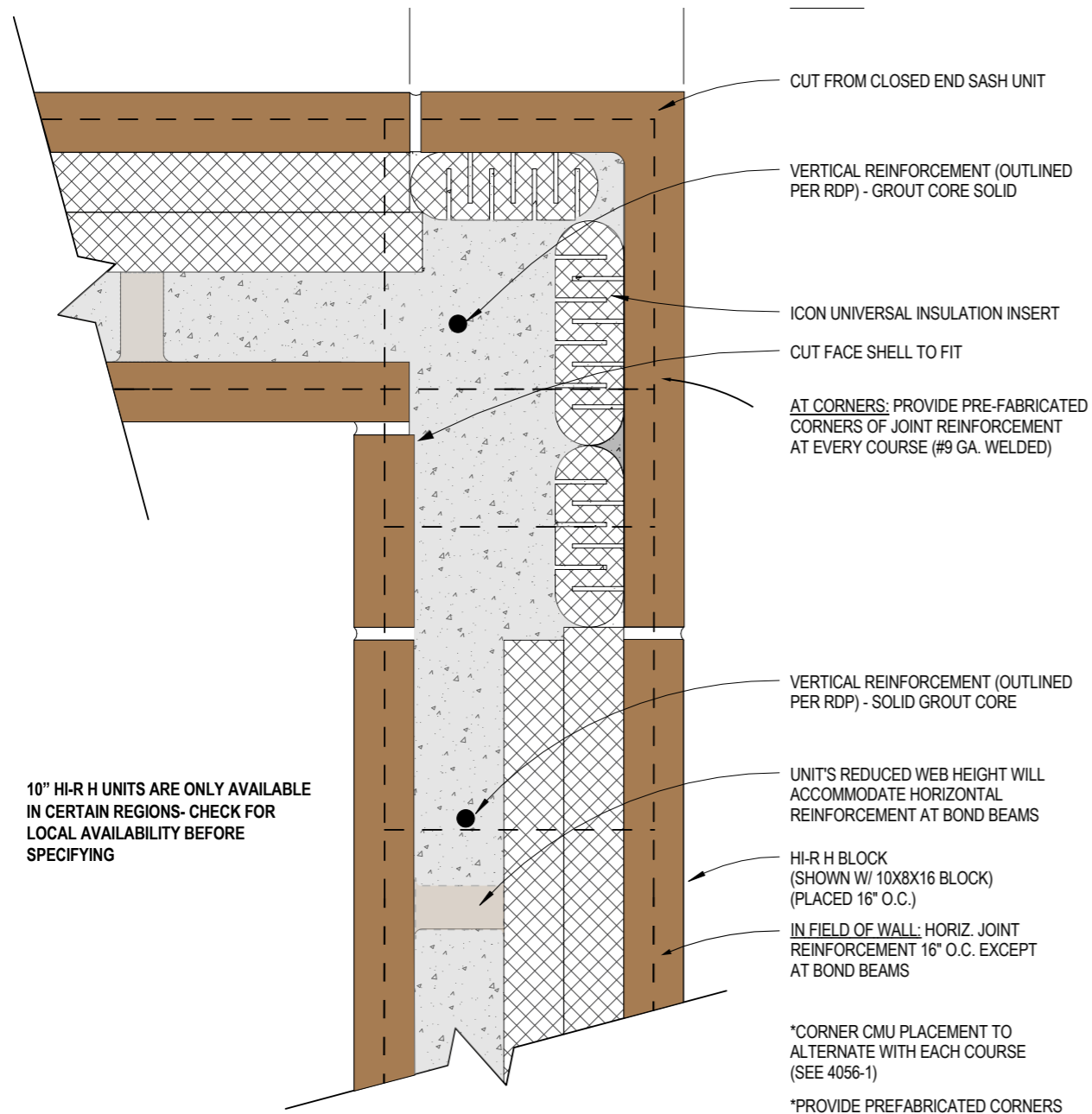

Notes:

1. The 10" version of HI-R-H is limited to regional availability. Please check with your local manufacturer prior to specification.
2. This detail illustrates how to build bonded corners with HI-R-H that meet structural requirements while maintaining insulation at the corner locations. This detail uses an exterior soap and cuts to the HI-R-H Units to form the corner. While this approach requires cutting both HI-R Units, the only separate fitting required for the corner is the soap.
3. Avoid bonded corners to save cost and time of construction. Not all designs require a bonded corner.
4. HI-R-H units can serve both as stretcher and bond beam unit without any modification. The reduced web height accommodates horizontal rebar. They are designed for construction of fully grouted and reinforced walls because they can be placed at rebar locations without the need to lift the unit over the top of the rebar as would be necessary with a more traditional CMU design, and grout will flow laterally at every course due to the reduced web heights.
5. HI-R-H units can also combine readily with conventional masonry fittings for construction of a variety of wall assembly details, including corners, joints, ends, and sills.

Codes and Standards References

Applicable References are found in Section III.

THE DETAILS PRESENTED IN THIS MANUAL ARE STANDARD DETAILS. DESIGNERS SHOULD MAKE SITE SPECIFIC INVESTIGATIONS TO DETERMINE ACTUAL DESIGN REQUIREMENTS, WHICH MAY VARY.

CPG IS NOT RESPONSIBLE FOR USES OF THIS INFORMATION BY THIRD PARTIES, AND DOES NOT WARRANT THE FITNESS OR SUITABILITY OF THIS INFORMATION FOR ANY PURPOSE. PERSONS MAKING USE OF THIS INFORMATION DO SO AT THEIR OWN RISK.

THESE STANDARD DETAILS ARE MEANT TO ILLUSTRATE GENERAL PRINCIPLES THAT MAY BE HELPFUL, HOWEVER, FINAL DESIGN AND CONSTRUCTION SHOULD BE BASED ON ACTUAL SITE CONDITIONS AND APPLICABLE LOCAL CODE AND STANDARDS. MANY SITE OR LOCAL CONDITIONS MAY REQUIRE SPECIFIC ADDITIONAL DESIGN CONSIDERATIONS. SUCH CONDITIONS MAY INCLUDE SEISMIC ACTIVITY, LOCAL CLIMATE, WIND LOAD AND STORM CONDITIONS (INCLUDING LIKELIHOOD OF TORNADO OR HURRICANE CONDITIONS), SITE SOILS AND DRAINAGE CONSIDERATIONS, AND A VARIETY OF OTHER FACTORS THAT MAY IMPACT BUILDING PERFORMANCE ON A PARTICULAR SITE.



Figure 29. 10" HI-R-H Bonded Corner L-Shape Veneer – course 1

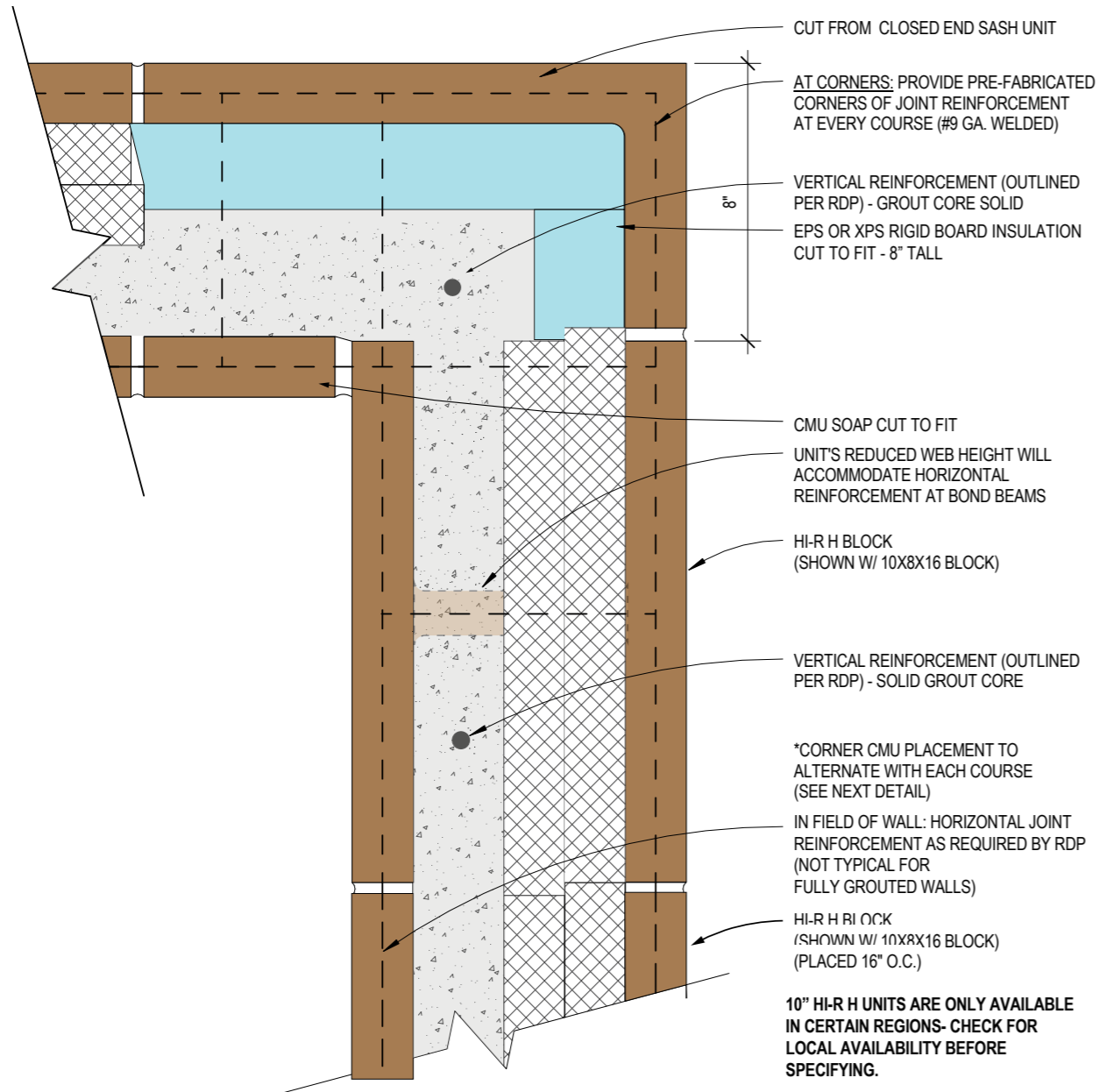

Notes:

1. The 10" version of HI-R-H is limited to regional availability. Please check with your local manufacturer prior to specification.
2. This detail illustrates how to build bonded corners with HI-R-H that meet structural requirements while maintaining insulation at the corner locations. This detail uses an exterior soap and cuts to the HI-R-H Units to form the corner. While this approach requires cutting both HI-R Units, the only separate fitting required for the corner is the soap.
3. Avoid bonded corners to save cost and time of construction. Not all designs require a bonded corner.
4. HI-R-H units can serve both as stretcher and bond beam unit without any modification. The reduced web height accommodates horizontal rebar. They are designed for construction of fully grouted and reinforced walls because they can be placed at rebar locations without the need to lift the unit over the top of the rebar as would be necessary with a more traditional CMU design, and grout will flow laterally at every course due to the reduced web heights.
5. HI-R-H units can also combine readily with conventional masonry fittings for construction of a variety of wall assembly details, including corners, joints, ends, and sills.

Codes and Standards References

Applicable References are found in Section III.

THE DETAILS PRESENTED IN THIS MANUAL ARE STANDARD DETAILS. DESIGNERS SHOULD MAKE SITE SPECIFIC INVESTIGATIONS TO DETERMINE ACTUAL DESIGN REQUIREMENTS, WHICH MAY VARY.

CPG IS NOT RESPONSIBLE FOR USES OF THIS INFORMATION BY THIRD PARTIES, AND DOES NOT WARRANT THE FITNESS OR SUITABILITY OF THIS INFORMATION FOR ANY PURPOSE. PERSONS MAKING USE OF THIS INFORMATION DO SO AT THEIR OWN RISK.

THESE STANDARD DETAILS ARE MEANT TO ILLUSTRATE GENERAL PRINCIPLES THAT MAY BE HELPFUL, HOWEVER, FINAL DESIGN AND CONSTRUCTION SHOULD BE BASED ON ACTUAL SITE CONDITIONS AND APPLICABLE LOCAL CODE AND STANDARDS. MANY SITE OR LOCAL CONDITIONS MAY REQUIRE SPECIFIC ADDITIONAL DESIGN CONSIDERATIONS. SUCH CONDITIONS MAY INCLUDE SEISMIC ACTIVITY, LOCAL CLIMATE, WIND LOAD AND STORM CONDITIONS (INCLUDING LIKELIHOOD OF TORNADO OR HURRICANE CONDITIONS), SITE SOILS AND DRAINAGE CONSIDERATIONS, AND A VARIETY OF OTHER FACTORS THAT MAY IMPACT BUILDING PERFORMANCE ON A PARTICULAR SITE.



Figure 30. 10" HI-R-H Bonded Corner L-Shape Veneer – course 2

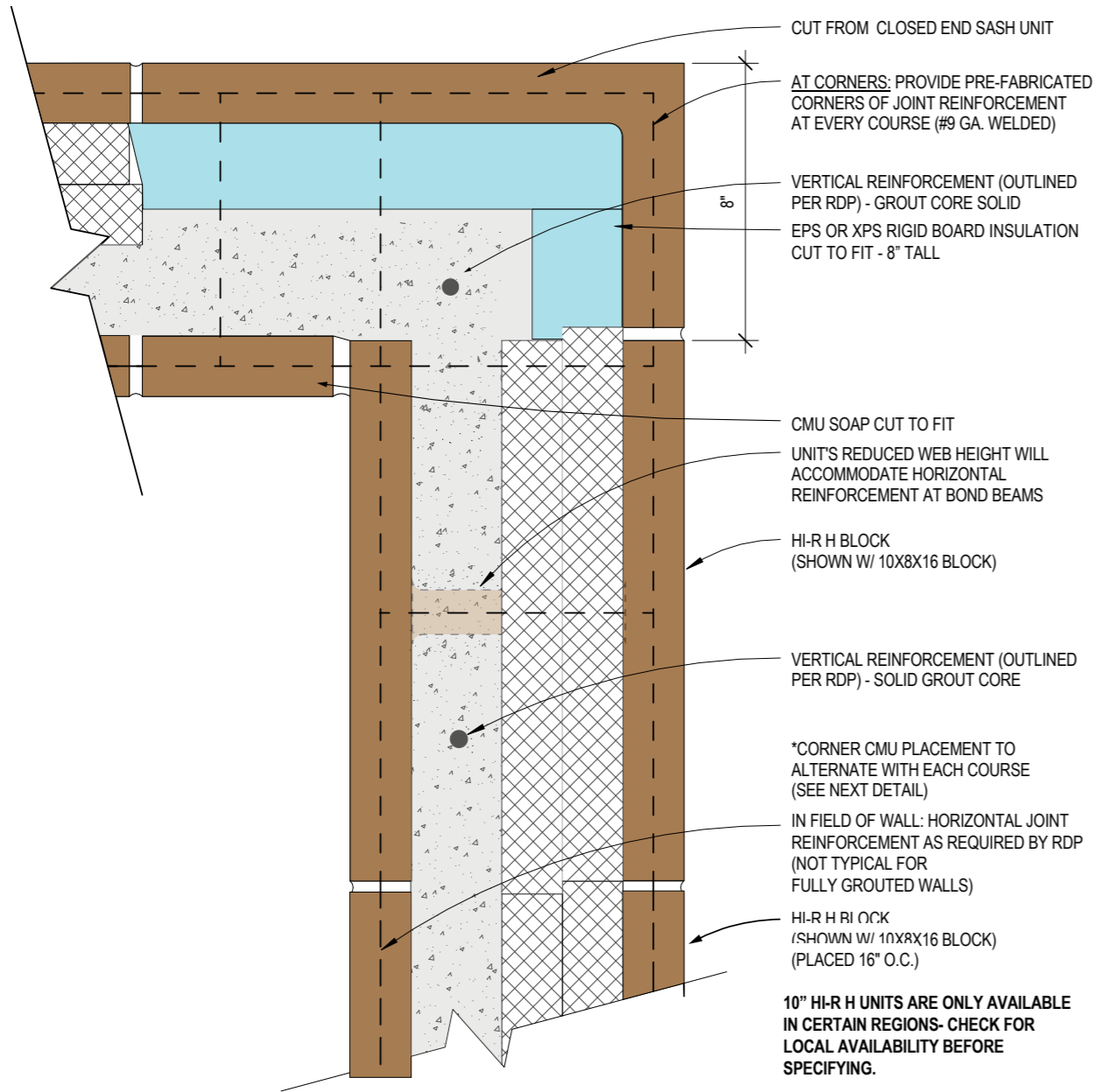

Notes:

1. The 10" version of HI-R-H is limited to regional availability. Please check with your local manufacturer prior to specification.
2. This detail illustrates how to build bonded corners with HI-R-H that meet structural requirements while maintaining insulation at the corner locations. This detail uses an exterior soap and cuts to the HI-R-H Units to form the corner. While this approach requires cutting both HI-R Units, the only separate fitting required for the corner is the soap.
3. Avoid bonded corners to save cost and time of construction. Not all designs require a bonded corner.
4. HI-R-H units can serve both as stretcher and bond beam unit without any modification. The reduced web height accommodates horizontal rebar. They are designed for construction of fully grouted and reinforced walls because they can be placed at rebar locations without the need to lift the unit over the top of the rebar as would be necessary with a more traditional CMU design, and grout will flow laterally at every course due to the reduced web heights.
5. HI-R-H units can also combine readily with conventional masonry fittings for construction of a variety of wall assembly details, including corners, joints, ends, and sills.

Codes and Standards References

Applicable References are found in Section III.

THE DETAILS PRESENTED IN THIS MANUAL ARE STANDARD DETAILS. DESIGNERS SHOULD MAKE SITE SPECIFIC INVESTIGATIONS TO DETERMINE ACTUAL DESIGN REQUIREMENTS, WHICH MAY VARY.

CPG IS NOT RESPONSIBLE FOR USES OF THIS INFORMATION BY THIRD PARTIES, AND DOES NOT WARRANT THE FITNESS OR SUITABILITY OF THIS INFORMATION FOR ANY PURPOSE. PERSONS MAKING USE OF THIS INFORMATION DO SO AT THEIR OWN RISK.

THESE STANDARD DETAILS ARE MEANT TO ILLUSTRATE GENERAL PRINCIPLES THAT MAY BE HELPFUL, HOWEVER, FINAL DESIGN AND CONSTRUCTION SHOULD BE BASED ON ACTUAL SITE CONDITIONS AND APPLICABLE LOCAL CODE AND STANDARDS. MANY SITE OR LOCAL CONDITIONS MAY REQUIRE SPECIFIC ADDITIONAL DESIGN CONSIDERATIONS. SUCH CONDITIONS MAY INCLUDE SEISMIC ACTIVITY, LOCAL CLIMATE, WIND LOAD AND STORM CONDITIONS (INCLUDING LIKELIHOOD OF TORNADO OR HURRICANE CONDITIONS), SITE SOILS AND DRAINAGE CONSIDERATIONS, AND A VARIETY OF OTHER FACTORS THAT MAY IMPACT BUILDING PERFORMANCE ON A PARTICULAR SITE.



Figure 31. 12" Bonded HI-R-H Corner – Exterior Soap

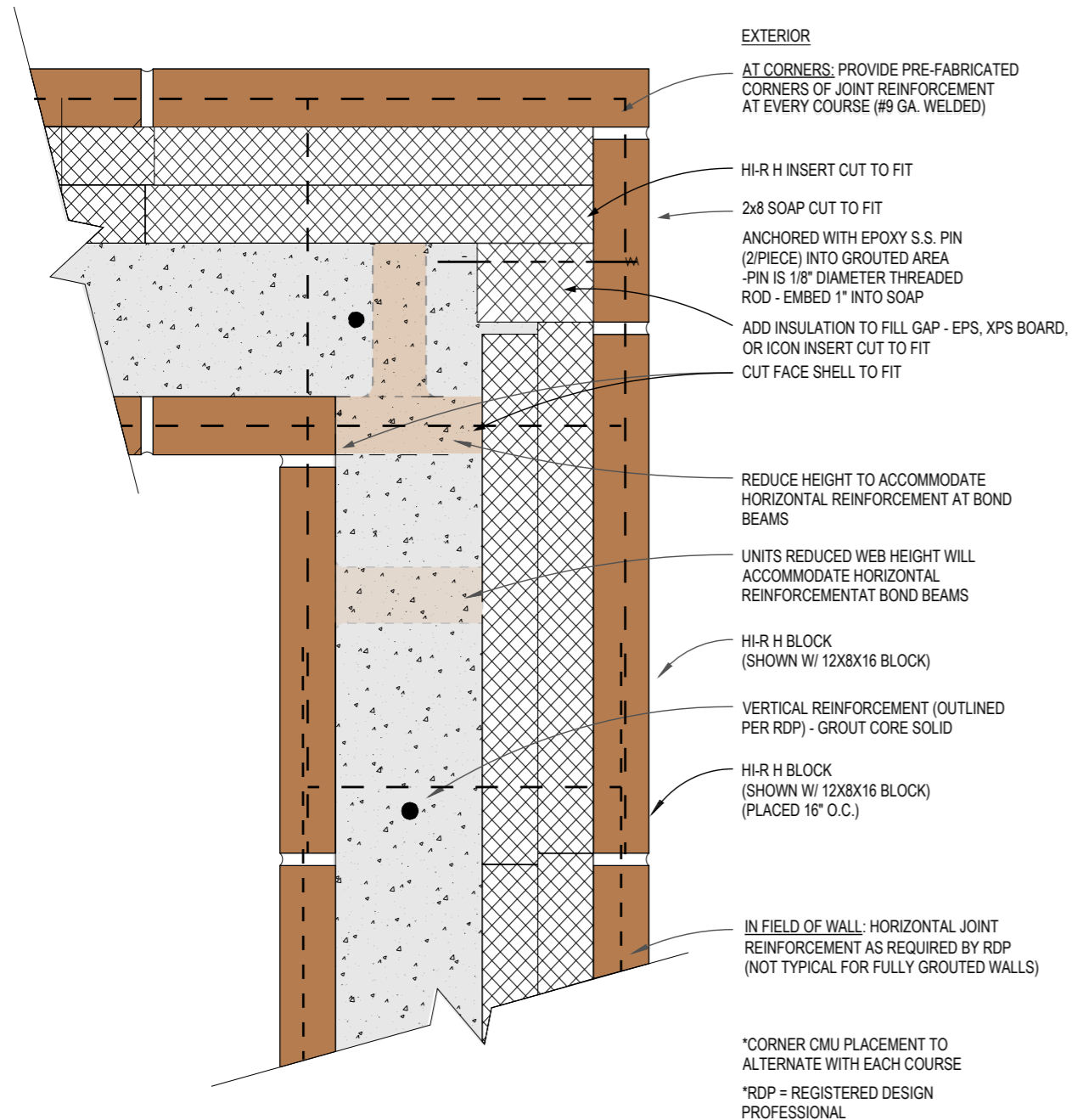

Notes:

1. This detail illustrates how to build bonded corners with HI-R-H that meet structural requirements while maintaining insulation at the corner locations. This detail uses an exterior soap and cuts to the HI-R-H Units to form the corner. While this approach requires cutting both HI-R Units, the only separate fitting required for the corner is the soap.
2. The same style corner can be constructed with the HI-R-H Half High product.
3. Avoid bonded corners to save cost and time of construction. Not all designs require a bonded corner.
4. HI-R-H units can serve both as stretcher and bond beam unit without any modification. The reduced web height accommodates horizontal rebar. They are designed for construction of fully grouted and reinforced walls because they can be placed at rebar locations without the need to lift the unit over the top of the rebar as would be necessary with a more traditional CMU design, and grout will flow laterally at every course due to the reduced web heights.
5. HI-R-H units can also combine readily with conventional masonry fittings for construction of a variety of wall assembly details, including corners, joints, ends, and sills.

Codes and Standards References

Applicable References are found in Section III.

THE DETAILS PRESENTED IN THIS MANUAL ARE STANDARD DETAILS. DESIGNERS SHOULD MAKE SITE SPECIFIC INVESTIGATIONS TO DETERMINE ACTUAL DESIGN REQUIREMENTS, WHICH MAY VARY.

CPG IS NOT RESPONSIBLE FOR USES OF THIS INFORMATION BY THIRD PARTIES, AND DOES NOT WARRANT THE FITNESS OR SUITABILITY OF THIS INFORMATION FOR ANY PURPOSE. PERSONS MAKING USE OF THIS INFORMATION DO SO AT THEIR OWN RISK.

THESE STANDARD DETAILS ARE MEANT TO ILLUSTRATE GENERAL PRINCIPLES THAT MAY BE HELPFUL, HOWEVER, FINAL DESIGN AND CONSTRUCTION SHOULD BE BASED ON ACTUAL SITE CONDITIONS AND APPLICABLE LOCAL CODE AND STANDARDS. MANY SITE OR LOCAL CONDITIONS MAY REQUIRE SPECIFIC ADDITIONAL DESIGN CONSIDERATIONS. SUCH CONDITIONS MAY INCLUDE SEISMIC ACTIVITY, LOCAL CLIMATE, WIND LOAD AND STORM CONDITIONS (INCLUDING LIKELIHOOD OF TORNADO OR HURRICANE CONDITIONS), SITE SOILS AND DRAINAGE CONSIDERATIONS, AND A VARIETY OF OTHER FACTORS THAT MAY IMPACT BUILDING PERFORMANCE ON A PARTICULAR SITE.



Figure 32 12" HI-R-H Bonded Corner – L-Shape Veneer (ICON inserts) – Course 1

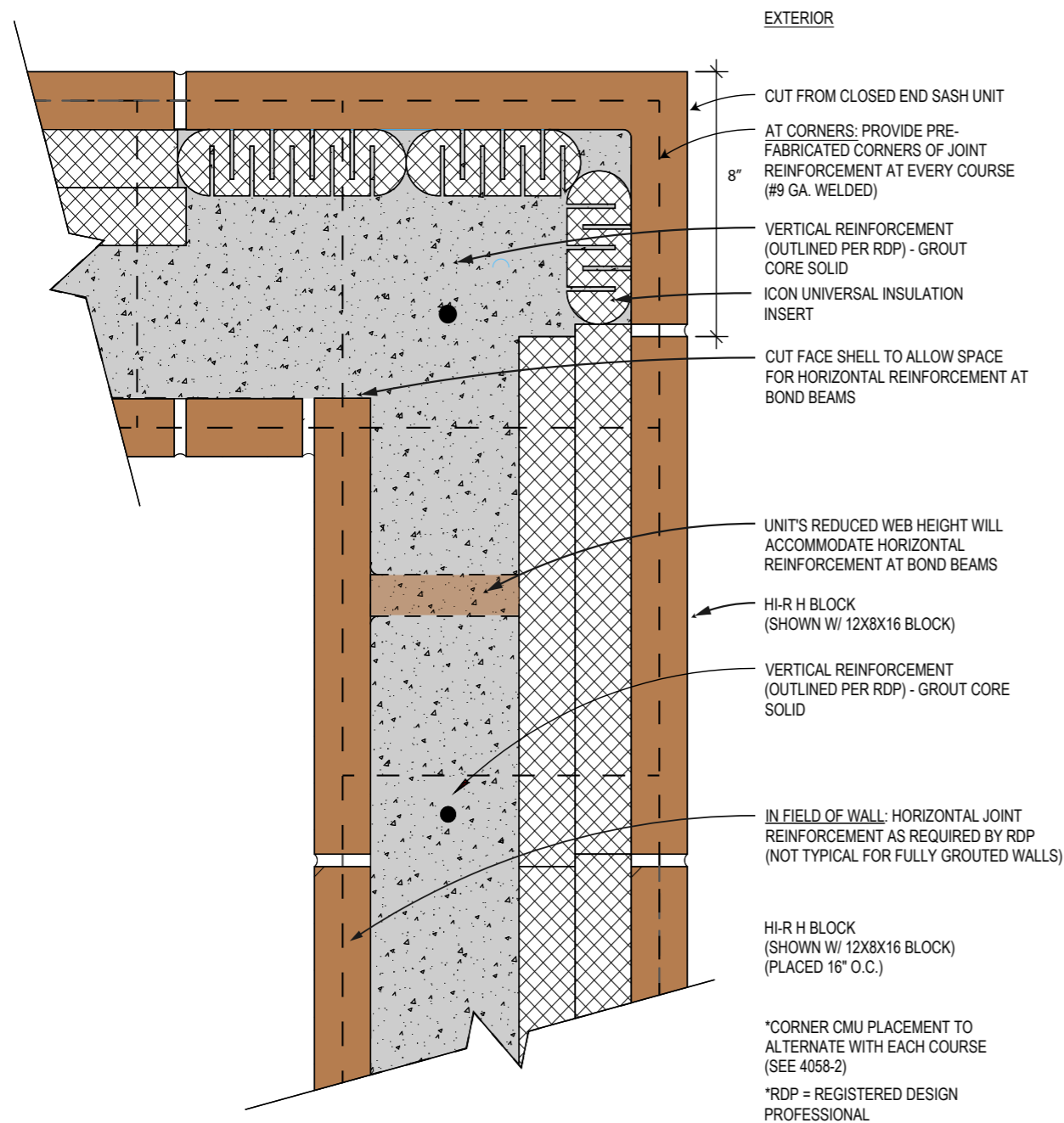

Notes:

1. This detail illustrates how to build bonded corners with HI-R-H that meet structural requirements while maintaining insulation at the corner locations. This detail uses an exterior soap and cuts to the HI-R-H Units to form the corner. While this approach requires cutting both HI-R Units, the only separate fitting required for the corner is the soap.
2. The same style corner can be constructed with the HI-R-H Half High product.
3. Avoid bonded corners to save cost and time of construction. Not all designs require a bonded corner.
4. HI-R-H units can serve both as stretcher and bond beam unit without any modification. The reduced web height accommodates horizontal rebar. They are designed for construction of fully grouted and reinforced walls because they can be placed at rebar locations without the need to lift the unit over the top of the rebar as would be necessary with a more traditional CMU design, and grout will flow laterally at every course due to the reduced web heights.
5. HI-R-H units can also combine readily with conventional masonry fittings for construction of a variety of wall assembly details, including corners, joints, ends, and sills.

Codes and Standards References

Applicable References are found in Section III.

THE DETAILS PRESENTED IN THIS MANUAL ARE STANDARD DETAILS. DESIGNERS SHOULD MAKE SITE SPECIFIC INVESTIGATIONS TO DETERMINE ACTUAL DESIGN REQUIREMENTS, WHICH MAY VARY.

CPG IS NOT RESPONSIBLE FOR USES OF THIS INFORMATION BY THIRD PARTIES, AND DOES NOT WARRANT THE FITNESS OR SUITABILITY OF THIS INFORMATION FOR ANY PURPOSE. PERSONS MAKING USE OF THIS INFORMATION DO SO AT THEIR OWN RISK.

THESE STANDARD DETAILS ARE MEANT TO ILLUSTRATE GENERAL PRINCIPLES THAT MAY BE HELPFUL, HOWEVER, FINAL DESIGN AND CONSTRUCTION SHOULD BE BASED ON ACTUAL SITE CONDITIONS AND APPLICABLE LOCAL CODE AND STANDARDS. MANY SITE OR LOCAL CONDITIONS MAY REQUIRE SPECIFIC ADDITIONAL DESIGN CONSIDERATIONS. SUCH CONDITIONS MAY INCLUDE SEISMIC ACTIVITY, LOCAL CLIMATE, WIND LOAD AND STORM CONDITIONS (INCLUDING LIKELIHOOD OF TORNADO OR HURRICANE CONDITIONS), SITE SOILS AND DRAINAGE CONSIDERATIONS, AND A VARIETY OF OTHER FACTORS THAT MAY IMPACT BUILDING PERFORMANCE ON A PARTICULAR SITE.



Figure 33. 12" HI-R-H Bonded Corner – L Shaped Veneer (ICON inserts) – Course 2

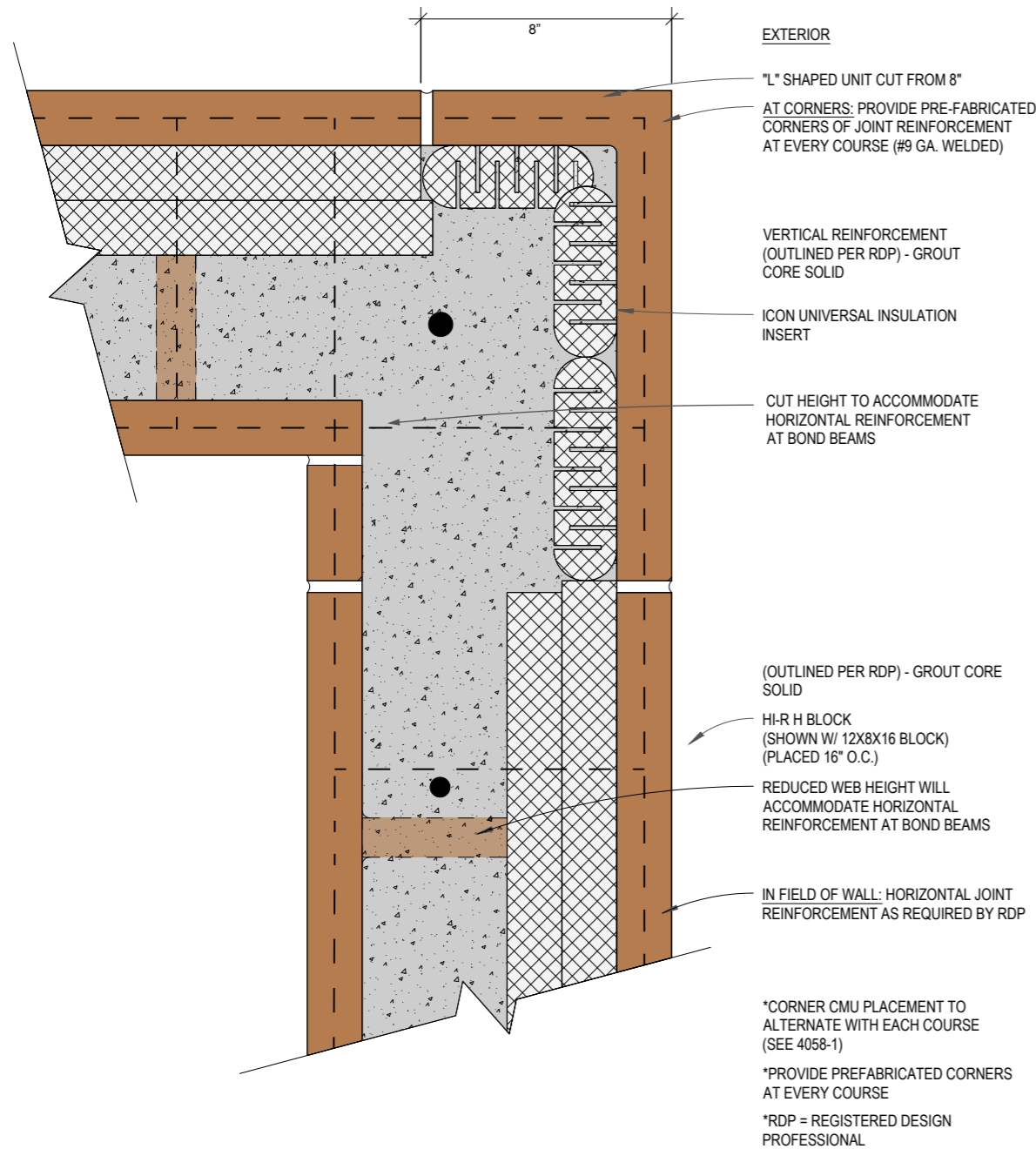

Notes:

1. This detail illustrates how to build bonded corners with HI-R-H that meet structural requirements while maintaining insulation at the corner locations. This detail uses an exterior soap and cuts to the HI-R-H Units to form the corner. While this approach requires cutting both HI-R Units, the only separate fitting required for the corner is the soap.
2. The same style corner can be constructed with the HI-R-H Half High product.
3. Avoid bonded corners to save cost and time of construction. Not all designs require a bonded corner.
4. HI-R-H units can serve both as stretcher and bond beam unit without any modification. The reduced web height accommodates horizontal rebar. They are designed for construction of fully grouted and reinforced walls because they can be placed at rebar locations without the need to lift the unit over the top of the rebar as would be necessary with a more traditional CMU design, and grout will flow laterally at every course due to the reduced web heights.
5. HI-R-H units can also combine readily with conventional masonry fittings for construction of a variety of wall assembly details, including corners, joints, ends, and sills.

Codes and Standards References

Applicable References are found in Section III.

THE DETAILS PRESENTED IN THIS MANUAL ARE STANDARD DETAILS. DESIGNERS SHOULD MAKE SITE SPECIFIC INVESTIGATIONS TO DETERMINE ACTUAL DESIGN REQUIREMENTS, WHICH MAY VARY.

CPG IS NOT RESPONSIBLE FOR USES OF THIS INFORMATION BY THIRD PARTIES, AND DOES NOT WARRANT THE FITNESS OR SUITABILITY OF THIS INFORMATION FOR ANY PURPOSE. PERSONS MAKING USE OF THIS INFORMATION DO SO AT THEIR OWN RISK.

THESE STANDARD DETAILS ARE MEANT TO ILLUSTRATE GENERAL PRINCIPLES THAT MAY BE HELPFUL, HOWEVER, FINAL DESIGN AND CONSTRUCTION SHOULD BE BASED ON ACTUAL SITE CONDITIONS AND APPLICABLE LOCAL CODE AND STANDARDS. MANY SITE OR LOCAL CONDITIONS MAY REQUIRE SPECIFIC ADDITIONAL DESIGN CONSIDERATIONS. SUCH CONDITIONS MAY INCLUDE SEISMIC ACTIVITY, LOCAL CLIMATE, WIND LOAD AND STORM CONDITIONS (INCLUDING LIKELIHOOD OF TORNADO OR HURRICANE CONDITIONS), SITE SOILS AND DRAINAGE CONSIDERATIONS, AND A VARIETY OF OTHER FACTORS THAT MAY IMPACT BUILDING PERFORMANCE ON A PARTICULAR SITE.



Figure 34. 12" HI-R-H Corner Bonded L-Shape Veneer (Rigid Board EPS)- Course 1

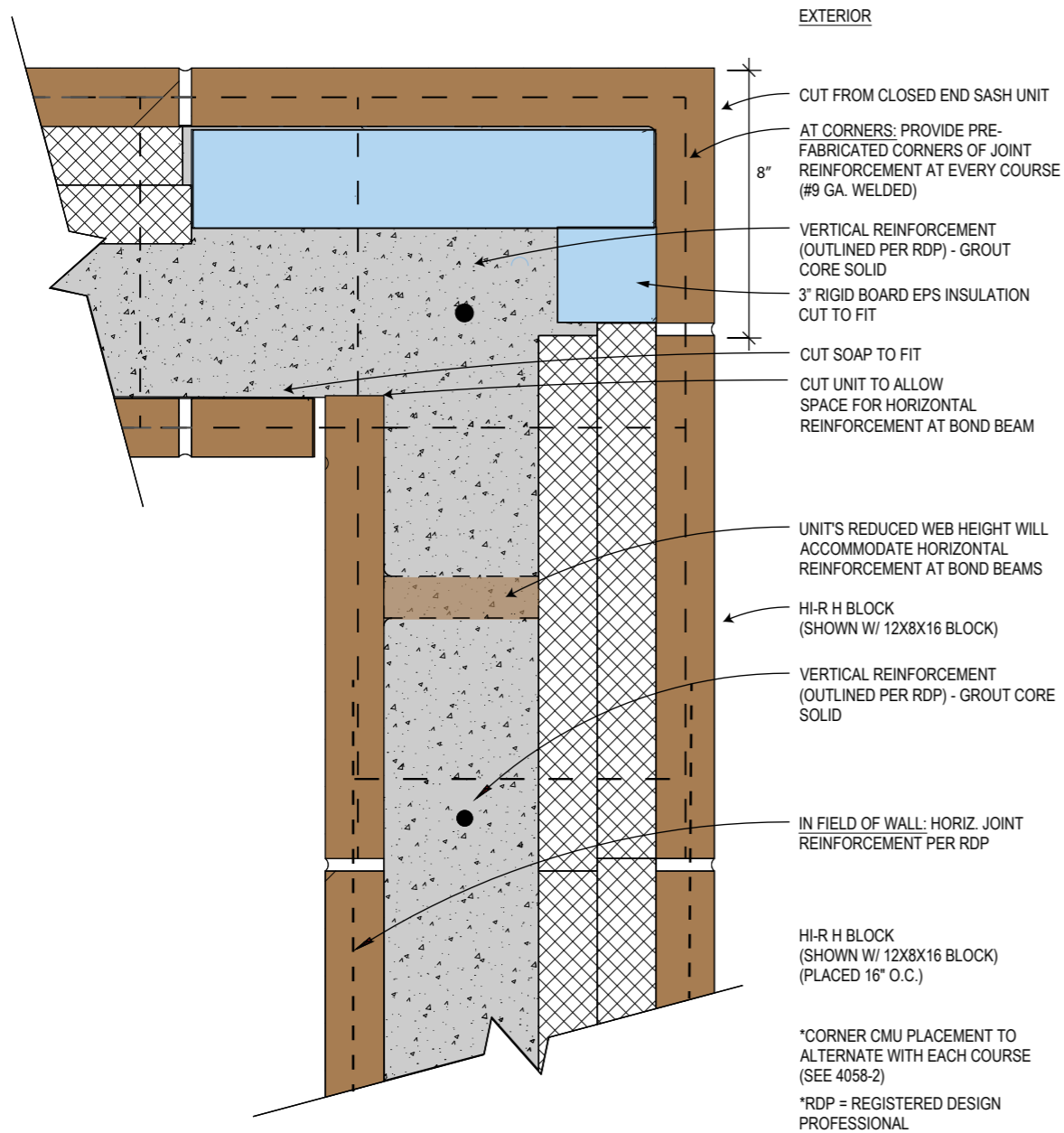

Notes:

1. This detail illustrates how to build bonded corners with HI-R-H that meet structural requirements while maintaining insulation at the corner locations. This detail uses an exterior soap and cuts to the HI-R-H Units to form the corner. While this approach requires cutting both HI-R Units, the only separate fitting required for the corner is the soap.
2. The same style corner can be constructed with the HI-R-H Half High product.
3. Avoid bonded corners to save cost and time of construction. Not all designs require a bonded corner.
4. HI-R-H units can serve both as stretcher and bond beam unit without any modification. The reduced web height accommodates horizontal rebar. They are designed for construction of fully grouted and reinforced walls because they can be placed at rebar locations without the need to lift the unit over the top of the rebar as would be necessary with a more traditional CMU design, and grout will flow laterally at every course due to the reduced web heights.
5. HI-R-H units can also combine readily with conventional masonry fittings for construction of a variety of wall assembly details, including corners, joints, ends, and sills.

Codes and Standards References

Applicable References are found in Section III.

THE DETAILS PRESENTED IN THIS MANUAL ARE STANDARD DETAILS. DESIGNERS SHOULD MAKE SITE SPECIFIC INVESTIGATIONS TO DETERMINE ACTUAL DESIGN REQUIREMENTS, WHICH MAY VARY.

CPG IS NOT RESPONSIBLE FOR USES OF THIS INFORMATION BY THIRD PARTIES, AND DOES NOT WARRANT THE FITNESS OR SUITABILITY OF THIS INFORMATION FOR ANY PURPOSE. PERSONS MAKING USE OF THIS INFORMATION DO SO AT THEIR OWN RISK.

THESE STANDARD DETAILS ARE MEANT TO ILLUSTRATE GENERAL PRINCIPLES THAT MAY BE HELPFUL, HOWEVER, FINAL DESIGN AND CONSTRUCTION SHOULD BE BASED ON ACTUAL SITE CONDITIONS AND APPLICABLE LOCAL CODE AND STANDARDS. MANY SITE OR LOCAL CONDITIONS MAY REQUIRE SPECIFIC ADDITIONAL DESIGN CONSIDERATIONS. SUCH CONDITIONS MAY INCLUDE SEISMIC ACTIVITY, LOCAL CLIMATE, WIND LOAD AND STORM CONDITIONS (INCLUDING LIKELIHOOD OF TORNADO OR HURRICANE CONDITIONS), SITE SOILS AND DRAINAGE CONSIDERATIONS, AND A VARIETY OF OTHER FACTORS THAT MAY IMPACT BUILDING PERFORMANCE ON A PARTICULAR SITE.



Figure 35. 12" HI-R-H Bonded Corner – L Shaped Veneer – course 2

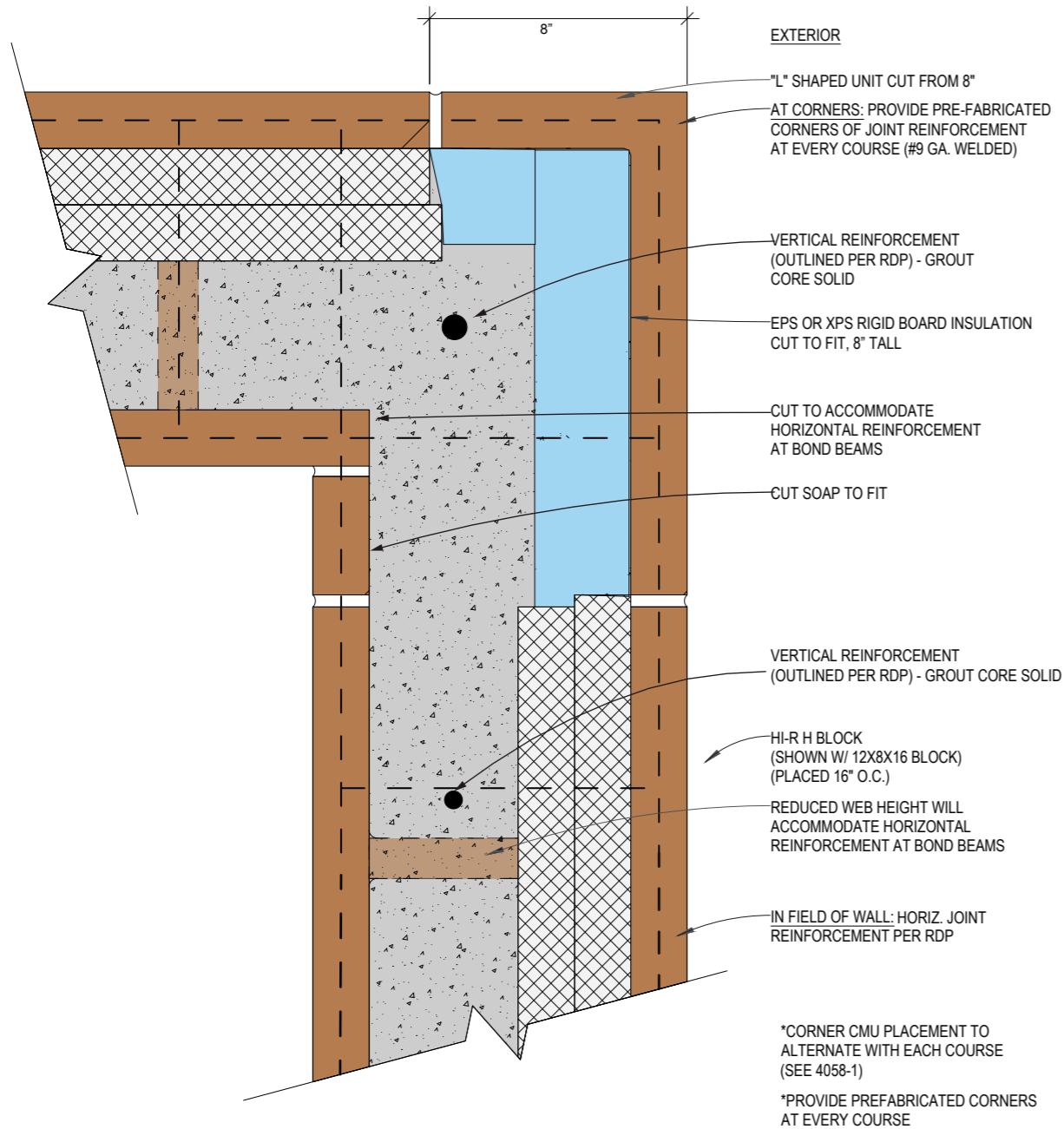

Notes:

1. This detail illustrates how to build bonded corners with HI-R-H that meet structural requirements while maintaining insulation at the corner locations. This detail uses an exterior soap and cuts to the HI-R-H Units to form the corner. While this approach requires cutting both HI-R Units, the only separate fitting required for the corner is the soap.
2. The same style corner can be constructed with the HI-R-H Half High product.
3. Avoid bonded corners to save cost and time of construction. Not all designs require a bonded corner.
4. HI-R-H units can serve both as stretcher and bond beam unit without any modification. The reduced web height accommodates horizontal rebar. They are designed for construction of fully grouted and reinforced walls because they can be placed at rebar locations without the need to lift the unit over the top of the rebar as would be necessary with a more traditional CMU design, and grout will flow laterally at every course due to the reduced web heights.
5. HI-R-H units can also combine readily with conventional masonry fittings for construction of a variety of wall assembly details, including corners, joints, ends, and sills.

Codes and Standards References

Applicable References are found in Section III.

THE DETAILS PRESENTED IN THIS MANUAL ARE STANDARD DETAILS. DESIGNERS SHOULD MAKE SITE SPECIFIC INVESTIGATIONS TO DETERMINE ACTUAL DESIGN REQUIREMENTS, WHICH MAY VARY.

CPG IS NOT RESPONSIBLE FOR USES OF THIS INFORMATION BY THIRD PARTIES, AND DOES NOT WARRANT THE FITNESS OR SUITABILITY OF THIS INFORMATION FOR ANY PURPOSE. PERSONS MAKING USE OF THIS INFORMATION DO SO AT THEIR OWN RISK.

THESE STANDARD DETAILS ARE MEANT TO ILLUSTRATE GENERAL PRINCIPLES THAT MAY BE HELPFUL, HOWEVER, FINAL DESIGN AND CONSTRUCTION SHOULD BE BASED ON ACTUAL SITE CONDITIONS AND APPLICABLE LOCAL CODE AND STANDARDS. MANY SITE OR LOCAL CONDITIONS MAY REQUIRE SPECIFIC ADDITIONAL DESIGN CONSIDERATIONS. SUCH CONDITIONS MAY INCLUDE SEISMIC ACTIVITY, LOCAL CLIMATE, WIND LOAD AND STORM CONDITIONS (INCLUDING LIKELIHOOD OF TORNADO OR HURRICANE CONDITIONS), SITE SOILS AND DRAINAGE CONSIDERATIONS, AND A VARIETY OF OTHER FACTORS THAT MAY IMPACT BUILDING PERFORMANCE ON A PARTICULAR SITE.



Figure 36. Corner using HI-R-H or HI-R-H Half High Jamb and Corner Unit

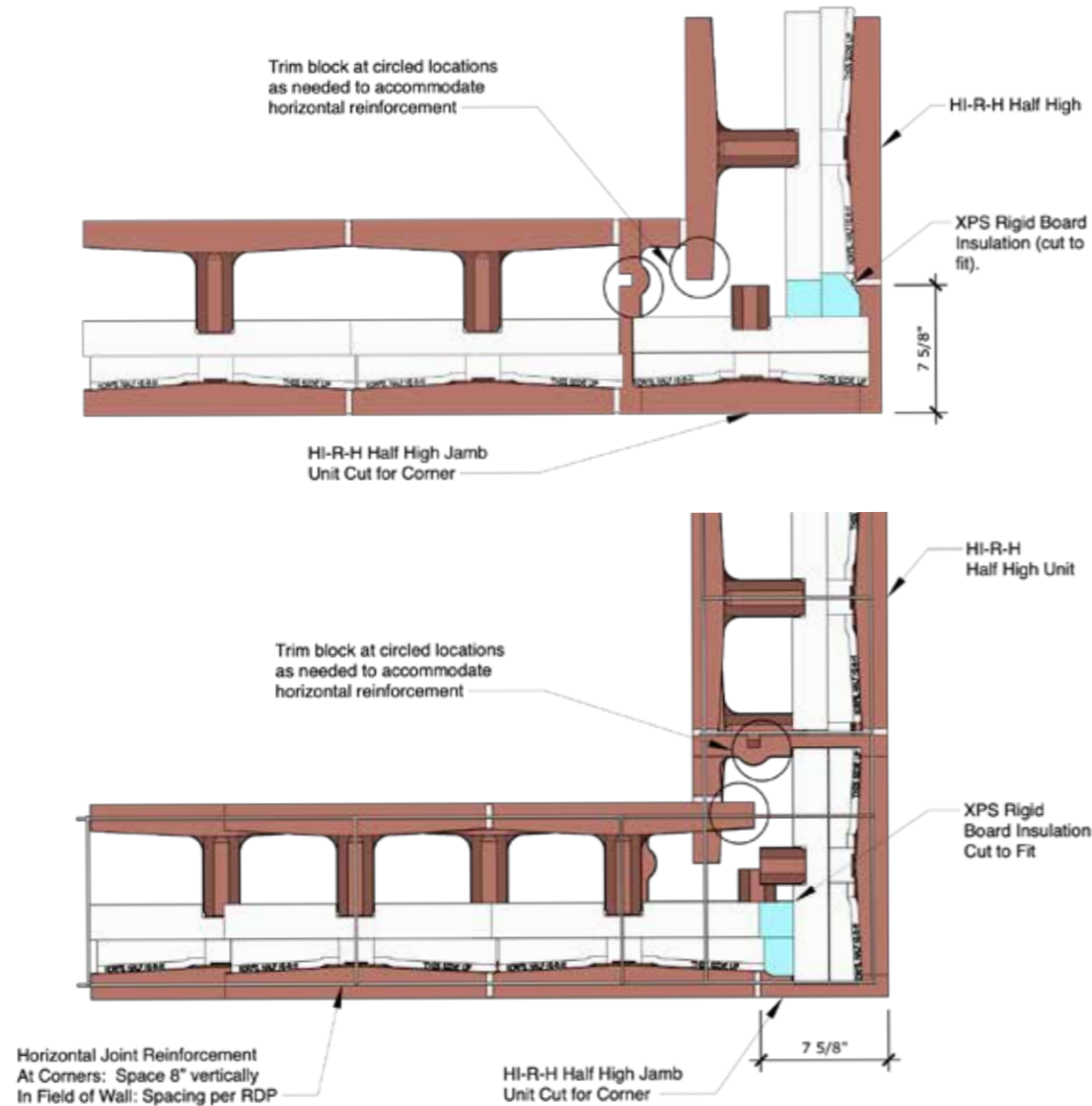

Notes:

1. The HI-R-H/HI-R-H Half High Corner and Jamb Unit is limited to regional availability, please check with your local manufacturer.
2. This detail illustrates how to build bonded corners with HI-R-H that meet structural requirements while maintaining insulation at the corner locations. This detail uses an exterior soap and cuts to the HI-R-H Units to form the corner. While this approach requires cutting both HI-R Units, the only separate fitting required for the corner is the soap.
3. The same style corner can be constructed with the HI-R-H and HI-R-H Half High product.
4. Avoid bonded corners to save cost and time of construction. Not all designs require a bonded corner.
5. HI-R-H units can serve both as stretcher and bond beam unit without any modification. The reduced web height accommodates horizontal rebar. They are designed for construction of fully grouted and reinforced walls because they can be placed at rebar locations without the need to lift the unit over the top of the rebar as would be necessary with a more traditional CMU design, and grout will flow laterally at every course due to the reduced web heights.
6. HI-R-H units can also combine readily with conventional masonry fittings for construction of a variety of wall assembly details, including corners, joints, ends, and sills.

Codes and Standards References

Applicable References are found in Section III.

THE DETAILS PRESENTED IN THIS MANUAL ARE STANDARD DETAILS. DESIGNERS SHOULD MAKE SITE SPECIFIC INVESTIGATIONS TO DETERMINE ACTUAL DESIGN REQUIREMENTS, WHICH MAY VARY.

CPG IS NOT RESPONSIBLE FOR USES OF THIS INFORMATION BY THIRD PARTIES, AND DOES NOT WARRANT THE FITNESS OR SUITABILITY OF THIS INFORMATION FOR ANY PURPOSE. PERSONS MAKING USE OF THIS INFORMATION DO SO AT THEIR OWN RISK.

THESE STANDARD DETAILS ARE MEANT TO ILLUSTRATE GENERAL PRINCIPLES THAT MAY BE HELPFUL, HOWEVER, FINAL DESIGN AND CONSTRUCTION SHOULD BE BASED ON ACTUAL SITE CONDITIONS AND APPLICABLE LOCAL CODE AND STANDARDS. MANY SITE OR LOCAL CONDITIONS MAY REQUIRE SPECIFIC ADDITIONAL DESIGN CONSIDERATIONS. SUCH CONDITIONS MAY INCLUDE SEISMIC ACTIVITY, LOCAL CLIMATE, WIND LOAD AND STORM CONDITIONS (INCLUDING LIKELIHOOD OF TORNADO OR HURRICANE CONDITIONS), SITE SOILS AND DRAINAGE CONSIDERATIONS, AND A VARIETY OF OTHER FACTORS THAT MAY IMPACT BUILDING PERFORMANCE ON A PARTICULAR SITE.

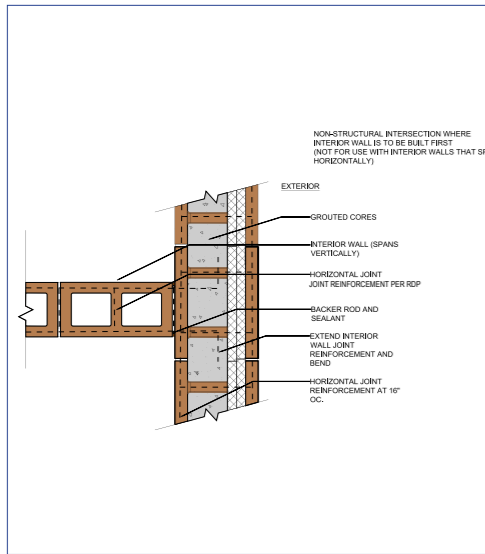

Figure 37. 12" HI-R "T" Intersection non-structural option 1

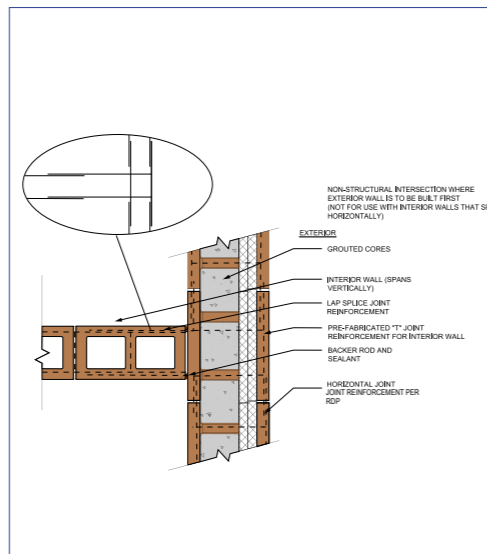

Figure 38. 12" HI-R "T" Intersection (non-structural) option 2

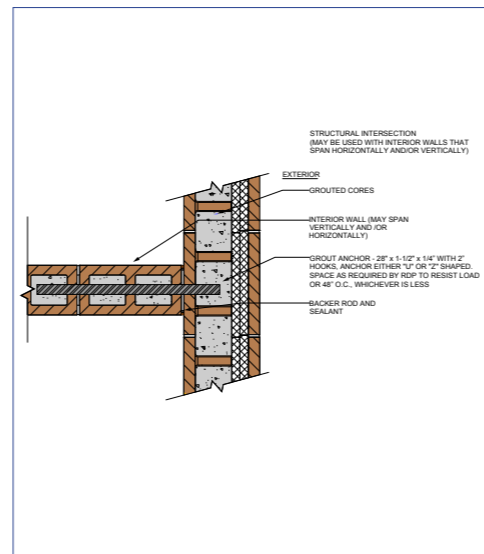

Figure 39. 12" HI-R "T" Intersection Structural - Option 1

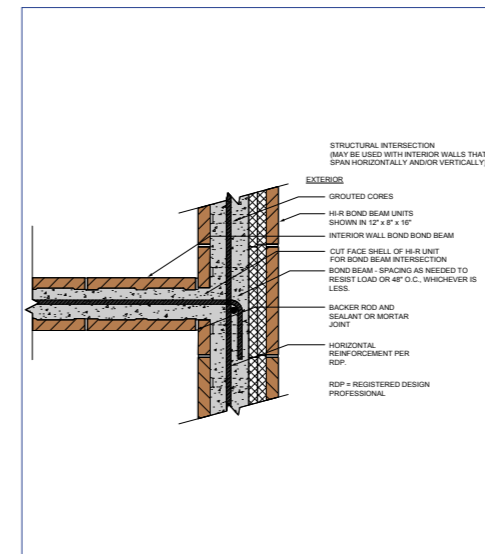

Figure 40. HI-R "T" Intersection Structural Option 2

[Click on drawings to enlarge](#)

Table of Contents	
1	Introduction
2	General Notes
3	Notes on Materials
4	Notes on Construction
5	Notes on Detailing
6	Notes on Reinforcement
7	Notes on Formwork
8	Notes on Curing
9	Notes on Protection
10	Notes on Inspection
11	Notes on Testing
12	Notes on Maintenance
13	Notes on Safety
14	Notes on Environmental Protection
15	Notes on Quality Control
16	Notes on Record Keeping
17	Notes on Training
18	Notes on Communication
19	Notes on Risk Management
20	Notes on Project Management
21	Notes on Client Relations
22	Notes on Stakeholder Engagement
23	Notes on Sustainability
24	Notes on Innovation
25	Notes on Continuous Improvement
26	Notes on Compliance
27	Notes on Ethics
28	Notes on Professionalism
29	Notes on Leadership
30	Notes on Teamwork
31	Notes on Problem Solving
32	Notes on Decision Making
33	Notes on Conflict Resolution
34	Notes on Negotiation
35	Notes on Persuasion
36	Notes on Influence
37	Notes on Power
38	Notes on Authority
39	Notes on Responsibility
40	Notes on Accountability
41	Notes on Transparency
42	Notes on Openness
43	Notes on Honesty
44	Notes on Integrity
45	Notes on Trust
46	Notes on Credibility
47	Notes on Reliability
48	Notes on Consistency
49	Notes on Predictability
50	Notes on Stability
51	Notes on Security
52	Notes on Safety
53	Notes on Health
54	Notes on Environment
55	Notes on Society
56	Notes on Culture
57	Notes on Values
58	Notes on Beliefs
59	Notes on Attitudes
60	Notes on Behaviors
61	Notes on Emotions
62	Notes on Cognition
63	Notes on Perception
64	Notes on Attention
65	Notes on Memory
66	Notes on Learning
67	Notes on Development
68	Notes on Growth
69	Notes on Change
70	Notes on Adaptation
71	Notes on Resilience
72	Notes on Flexibility
73	Notes on Creativity
74	Notes on Innovation
75	Notes on Entrepreneurship
76	Notes on Leadership
77	Notes on Management
78	Notes on Organization
79	Notes on Strategy
80	Notes on Planning
81	Notes on Execution
82	Notes on Monitoring
83	Notes on Evaluation
84	Notes on Improvement
85	Notes on Success
86	Notes on Failure
87	Notes on Learning
88	Notes on Growth
89	Notes on Change
90	Notes on Adaptation
91	Notes on Resilience
92	Notes on Flexibility
93	Notes on Creativity
94	Notes on Innovation
95	Notes on Entrepreneurship
96	Notes on Leadership
97	Notes on Management
98	Notes on Organization
99	Notes on Strategy
100	Notes on Planning

Intersections with Interior Walls

Figure 37. HI-R Bonded "T" intersection (Non-Structural) Option 1.

NON-STRUCTURAL INTERSECTION WHERE INTERIOR WALL IS TO BE BUILT FIRST (NOT FOR USE WITH INTERIOR WALLS THAT SPAN HORIZONTALLY)

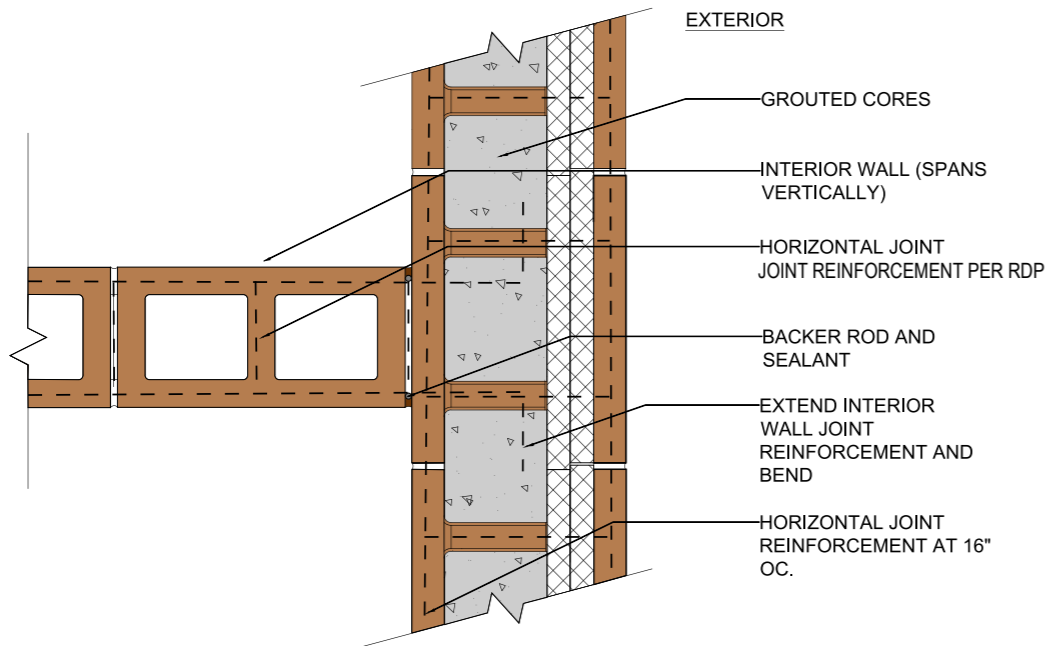

Notes:

1. This detail shows how to build a bonded "T" intersection between an interior partition wall and an exterior HI-R/Hi-R-H wall where the intersection is non-structural, and the interior wall is to be built first. This is suitable for walls that span vertically but not horizontally.
2. Not all T intersections require bonded construction. RDP to determine whether bonded detail is required.
3. When the interior wall is built, joint reinforcement is placed as required by the RDP. Where the partition is to meet the exterior wall, the joint reinforcement is extended past the end of the partition wall and will be bent when connected to the exterior wall.
4. HI-R and HI-R-H units can also combine readily with conventional masonry fittings for construction of a variety of wall assembly details, including corners, joints, ends, and sills.

Codes and Standards References

Applicable References are found in Section III.

THE DETAILS PRESENTED IN THIS MANUAL ARE STANDARD DETAILS. DESIGNERS SHOULD MAKE SITE SPECIFIC INVESTIGATIONS TO DETERMINE ACTUAL DESIGN REQUIREMENTS, WHICH MAY VARY.

CPG IS NOT RESPONSIBLE FOR USES OF THIS INFORMATION BY THIRD PARTIES, AND DOES NOT WARRANT THE FITNESS OR SUITABILITY OF THIS INFORMATION FOR ANY PURPOSE. PERSONS MAKING USE OF THIS INFORMATION DO SO AT THEIR OWN RISK.

THESE STANDARD DETAILS ARE MEANT TO ILLUSTRATE GENERAL PRINCIPLES THAT MAY BE HELPFUL, HOWEVER, FINAL DESIGN AND CONSTRUCTION SHOULD BE BASED ON ACTUAL SITE CONDITIONS AND APPLICABLE LOCAL CODE AND STANDARDS. MANY SITE OR LOCAL CONDITIONS MAY REQUIRE SPECIFIC ADDITIONAL DESIGN CONSIDERATIONS. SUCH CONDITIONS MAY INCLUDE SEISMIC ACTIVITY, LOCAL CLIMATE, WIND LOAD AND STORM CONDITIONS (INCLUDING LIKELIHOOD OF TORNADO OR HURRICANE CONDITIONS), SITE SOILS AND DRAINAGE CONSIDERATIONS, AND A VARIETY OF OTHER FACTORS THAT MAY IMPACT BUILDING PERFORMANCE ON A PARTICULAR SITE.



Figure 38. HI-R Bonded T Intersection (Non-Structural) Option 2

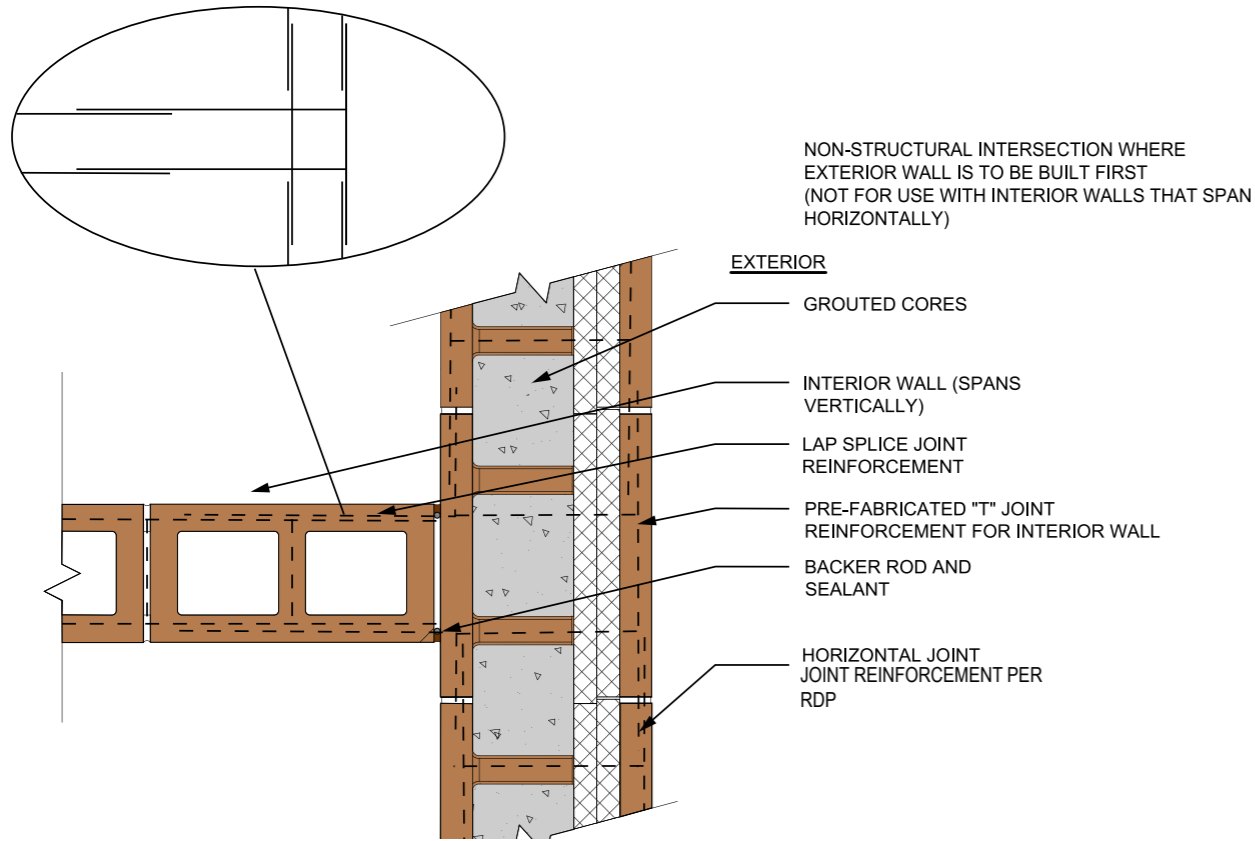

Notes:

1. This detail shows how to build a bonded "T" intersection between an interior partition wall and an exterior HI-R/HI-R-H wall where the intersection is non-structural, and the interior wall is to be built first. This is suitable for walls that span vertically but not horizontally.
2. Not all T intersections require bonded construction. RDP to determine whether bonded detail is required.
3. When the interior wall is built, joint reinforcement is placed as required by the RDP. Where the partition is to meet the exterior wall, the joint reinforcement is extended past the end of the partition wall and will be bent when connected to the exterior wall.
4. HI-R and HI-R-H units can also combine readily with conventional masonry fittings for construction of a variety of wall assembly details, including corners, joints, ends, and sills.

5. Codes and Standards References

Applicable References are found in Section III.

This is Detail 4071 in the CPG CAD details.

THE DETAILS PRESENTED IN THIS MANUAL ARE STANDARD DETAILS. DESIGNERS SHOULD MAKE SITE SPECIFIC INVESTIGATIONS TO DETERMINE ACTUAL DESIGN REQUIREMENTS, WHICH MAY VARY.

CPG IS NOT RESPONSIBLE FOR USES OF THIS INFORMATION BY THIRD PARTIES, AND DOES NOT WARRANT THE FITNESS OR SUITABILITY OF THIS INFORMATION FOR ANY PURPOSE. PERSONS MAKING USE OF THIS INFORMATION DO SO AT THEIR OWN RISK.

THESE STANDARD DETAILS ARE MEANT TO ILLUSTRATE GENERAL PRINCIPLES THAT MAY BE HELPFUL, HOWEVER, FINAL DESIGN AND CONSTRUCTION SHOULD BE BASED ON ACTUAL SITE CONDITIONS AND APPLICABLE LOCAL CODE AND STANDARDS. MANY SITE OR LOCAL CONDITIONS MAY REQUIRE SPECIFIC ADDITIONAL DESIGN CONSIDERATIONS. SUCH CONDITIONS MAY INCLUDE SEISMIC ACTIVITY, LOCAL CLIMATE, WIND LOAD AND STORM CONDITIONS (INCLUDING LIKELIHOOD OF TORNADO OR HURRICANE CONDITIONS), SITE SOILS AND DRAINAGE CONSIDERATIONS, AND A VARIETY OF OTHER FACTORS THAT MAY IMPACT BUILDING PERFORMANCE ON A PARTICULAR SITE.



Figure 39. HI-R Bonded "T" intersection (Structural) Option 1

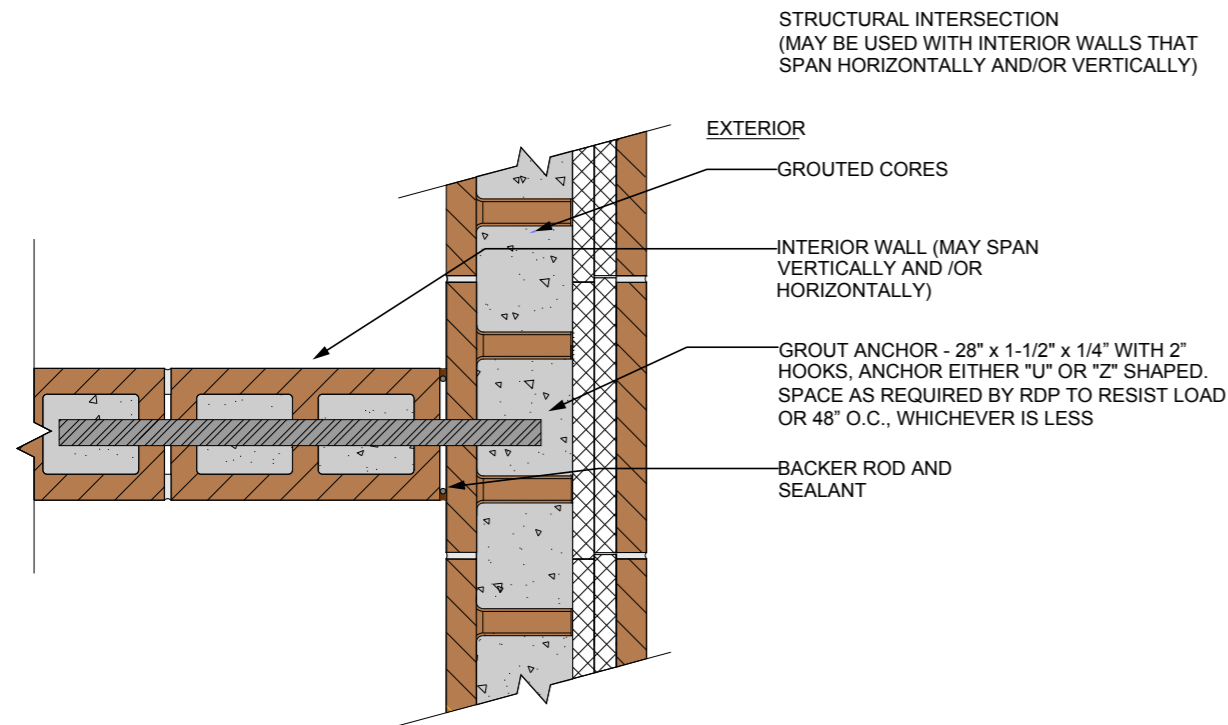

Notes:

1. This detail shows how to build a "T" intersection between an interior partition wall and an exterior HI-R/HI-R-H wall where the intersection is non-structural, and the **exterior** wall is to be built first. This is suitable for walls that span vertically but not horizontally.
2. Not all T intersections require bonded construction. RDP to determine whether bonded detail is required.
3. When the exterior wall is built, joint reinforcement is placed every 16" OC. Where the partition is to meet the interior wall, a pre-fabricated T section of joint reinforcement is placed so that the joint reinforcement will extend into the partition wall at the intersection.
4. HI-R and HI-R-H units can also combine readily with conventional masonry fittings for construction of a variety of wall assembly details, including corners, joints, ends, and sills.

Codes and Standards References

Applicable References are found in Section III.

This is Detail 4071 in the CPG CAD details.

THE DETAILS PRESENTED IN THIS MANUAL ARE STANDARD DETAILS. DESIGNERS SHOULD MAKE SITE SPECIFIC INVESTIGATIONS TO DETERMINE ACTUAL DESIGN REQUIREMENTS, WHICH MAY VARY.

CPG IS NOT RESPONSIBLE FOR USES OF THIS INFORMATION BY THIRD PARTIES, AND DOES NOT WARRANT THE FITNESS OR SUITABILITY OF THIS INFORMATION FOR ANY PURPOSE. PERSONS MAKING USE OF THIS INFORMATION DO SO AT THEIR OWN RISK.

THESE STANDARD DETAILS ARE MEANT TO ILLUSTRATE GENERAL PRINCIPLES THAT MAY BE HELPFUL, HOWEVER, FINAL DESIGN AND CONSTRUCTION SHOULD BE BASED ON ACTUAL SITE CONDITIONS AND APPLICABLE LOCAL CODE AND STANDARDS. MANY SITE OR LOCAL CONDITIONS MAY REQUIRE SPECIFIC ADDITIONAL DESIGN CONSIDERATIONS. SUCH CONDITIONS MAY INCLUDE SEISMIC ACTIVITY, LOCAL CLIMATE, WIND LOAD AND STORM CONDITIONS (INCLUDING LIKELIHOOD OF TORNADO OR HURRICANE CONDITIONS), SITE SOILS AND DRAINAGE CONSIDERATIONS, AND A VARIETY OF OTHER FACTORS THAT MAY IMPACT BUILDING PERFORMANCE ON A PARTICULAR SITE.



Figure 40. HI-R Bonded "T" intersection (Structural) Option 2

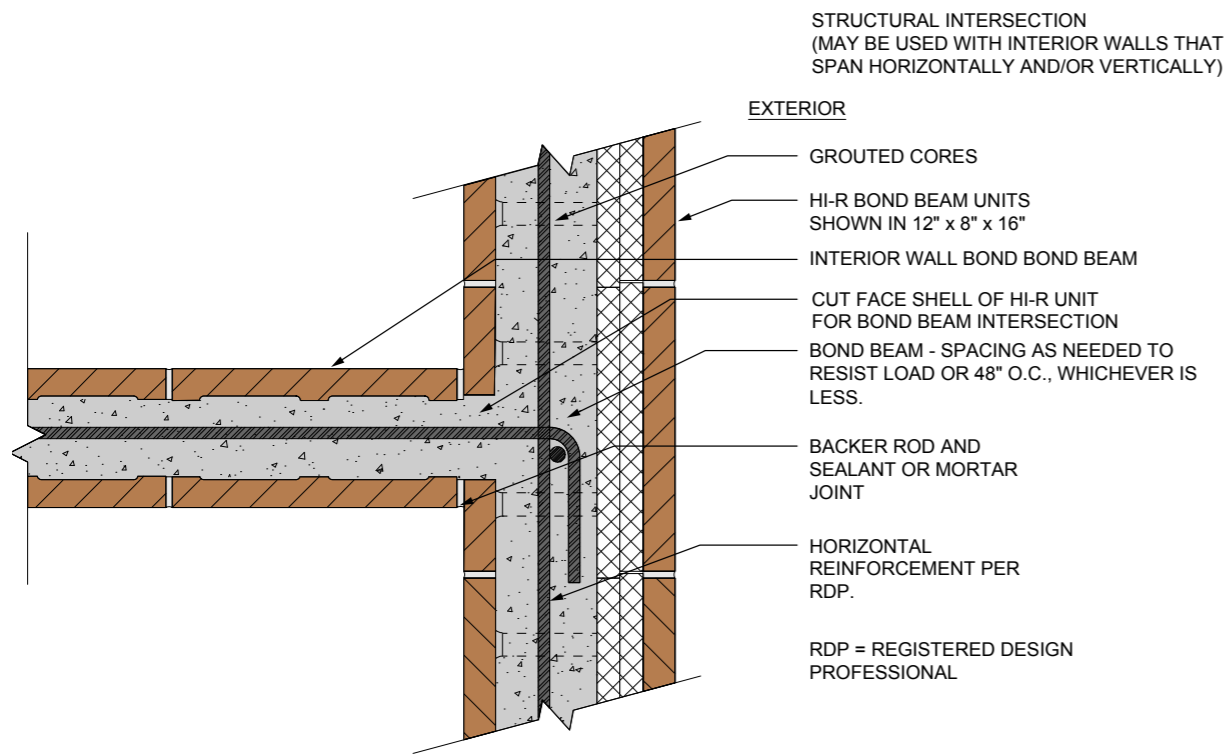

Notes:

1. This detail shows how to build a "T" intersection between an interior partition wall and an exterior HI-R/Hi-R-H wall where the intersection is Structural. This is suitable for walls that span vertically and/or horizontally.
2. This detail uses a bond beam for the connection at the intersection of the walls. HI-R units may be manufactured with reduced web height for bond beam units, or may be factory or field cut as knock out bond beam units. The standard CMU used for the interior partition wall may also be either manufactured as bond beam units or cut. Check with your local manufacturer for availability.
3. The spacing between bond beam units, and the selection of the type of steel reinforcement shall be specified by the Registered Design Professional based on project requirements.
4. HI-R and HI-R-H units can also combine readily with conventional masonry fittings for construction of a variety of wall assembly details, including corners, joints, ends, and sills.

Codes and Standards References

Applicable References are found in Section III.

This is Detail 4071 in the CPG CAD details.

THE DETAILS PRESENTED IN THIS MANUAL ARE STANDARD DETAILS. DESIGNERS SHOULD MAKE SITE SPECIFIC INVESTIGATIONS TO DETERMINE ACTUAL DESIGN REQUIREMENTS, WHICH MAY VARY.

CPG IS NOT RESPONSIBLE FOR USES OF THIS INFORMATION BY THIRD PARTIES, AND DOES NOT WARRANT THE FITNESS OR SUITABILITY OF THIS INFORMATION FOR ANY PURPOSE. PERSONS MAKING USE OF THIS INFORMATION DO SO AT THEIR OWN RISK.

THESE STANDARD DETAILS ARE MEANT TO ILLUSTRATE GENERAL PRINCIPLES THAT MAY BE HELPFUL, HOWEVER, FINAL DESIGN AND CONSTRUCTION SHOULD BE BASED ON ACTUAL SITE CONDITIONS AND APPLICABLE LOCAL CODE AND STANDARDS. MANY SITE OR LOCAL CONDITIONS MAY REQUIRE SPECIFIC ADDITIONAL DESIGN CONSIDERATIONS. SUCH CONDITIONS MAY INCLUDE SEISMIC ACTIVITY, LOCAL CLIMATE, WIND LOAD AND STORM CONDITIONS (INCLUDING LIKELIHOOD OF TORNADO OR HURRICANE CONDITIONS), SITE SOILS AND DRAINAGE CONSIDERATIONS, AND A VARIETY OF OTHER FACTORS THAT MAY IMPACT BUILDING PERFORMANCE ON A PARTICULAR SITE.



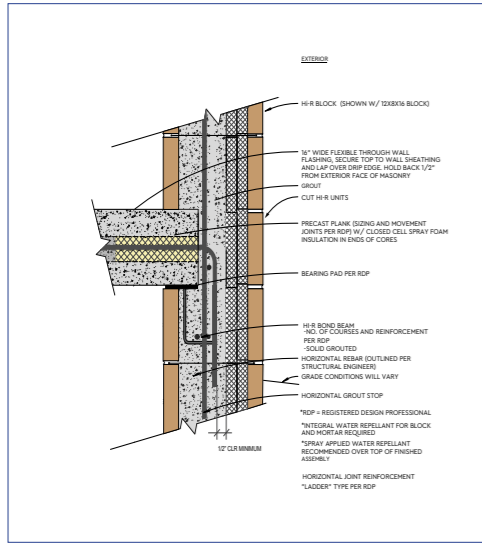

Figure 41. HI-R Plank-Bearing Wall Fully Grouted

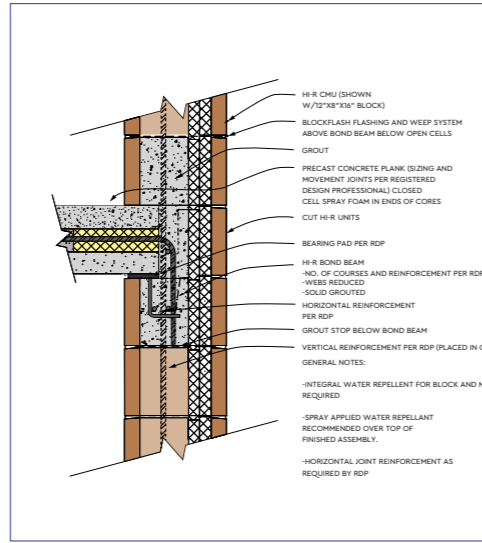

Figure 42. HI-R Plank-Bearing Wall Partially Grouted

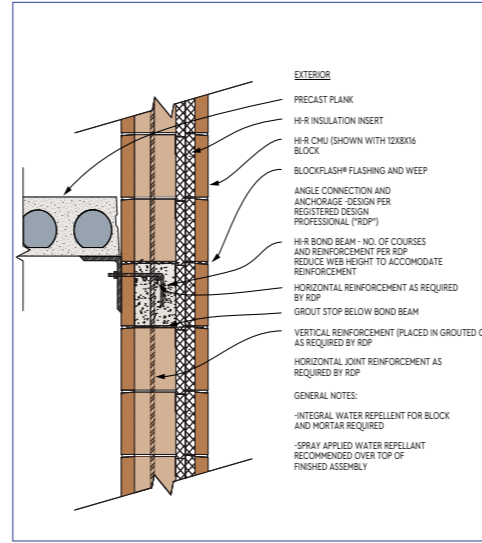

Figure 43. HI-R Plank Non-Bearing Wall Partially Grouted

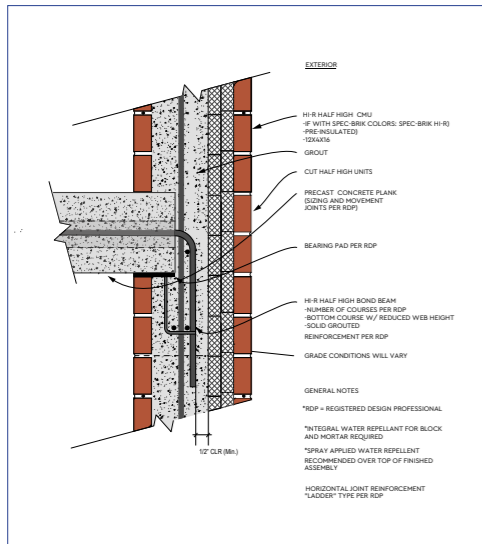

Figure 44. HI-R Half High Bearing Wall Fully Grouted

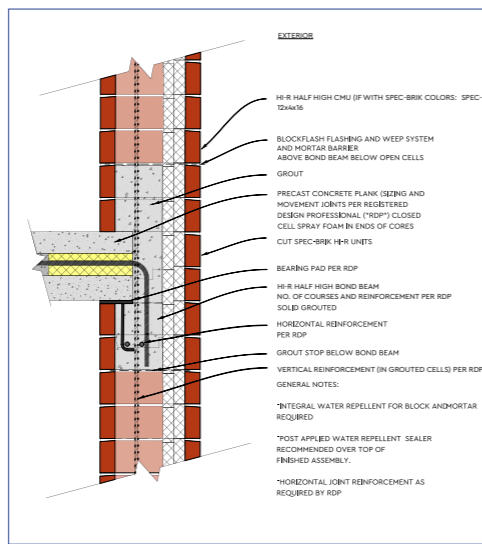

Figure 45. HI-R Half High Bearing Wall Partially Grouted

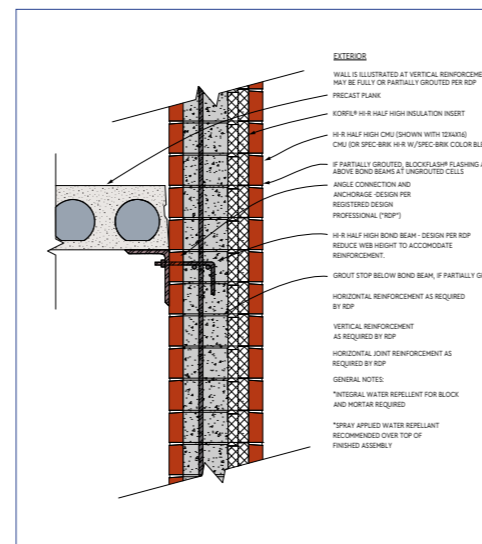

Figure 46. HI-R Half High Non-Bearing Wall Plank/Angle

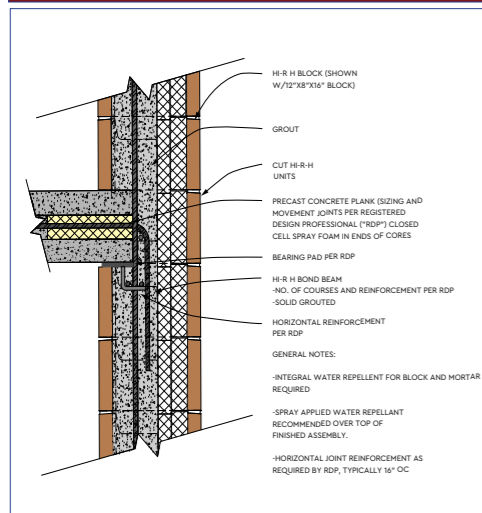

Figure 47. HI-R-H Plank Bearing Wall Fully Grouted

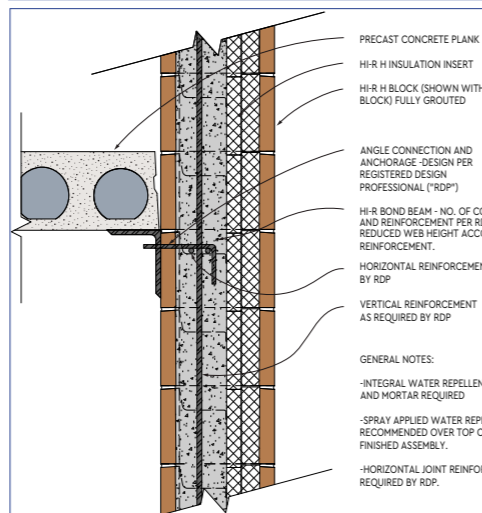

Figure 48. HI-R-H Non-Bearing Wall Plank/Angle

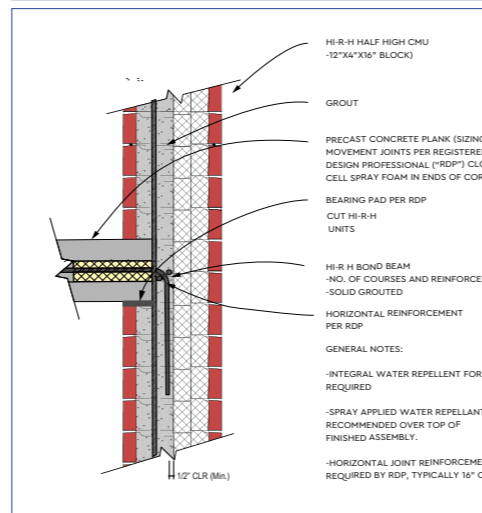

Figure 49. HI-R-H Half High Bearing Wall Plank

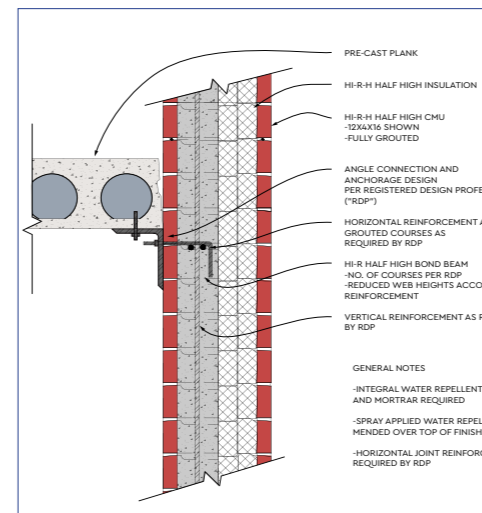
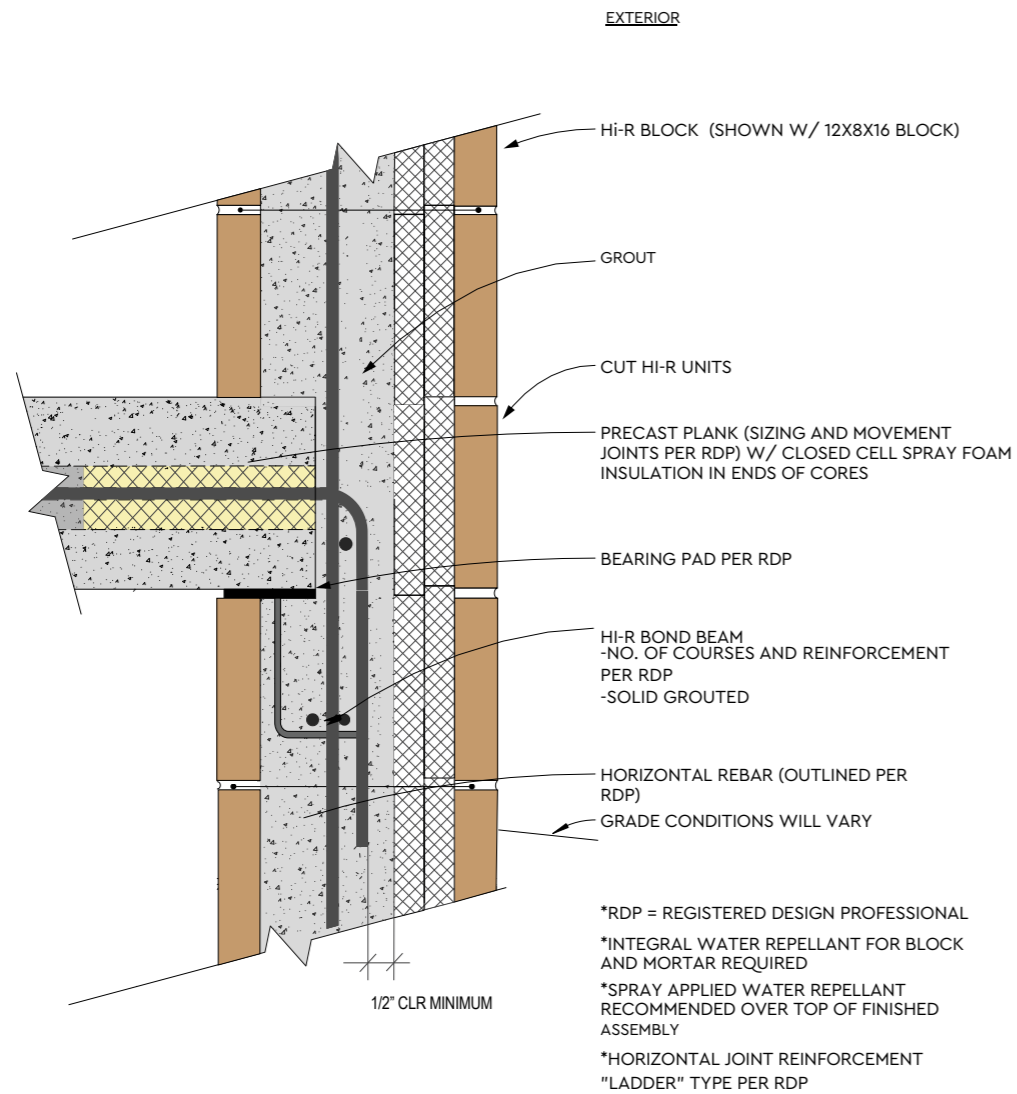

Figure 50. HI-R-H Half High Non-Bearing Wall Plank/Angle

Click on drawings to enlarge



Figure 41. HI-R Plank-Bearing Wall Fully Grouted



Notes:

1. This detail depicts a fully grouted wall. HI-R walls may be built either fully or partially grouted, while the HI-R-H products are fully grouted only. Fully grouting masonry walls is a cost-effective alternative to partially grouted walls. In many areas of the country where seismic design considerations are important, highly reinforced and fully grouted masonry is the preferred solution. Fully grouted walls do not require flashing at bond beam locations, and meet Code air barrier requirements.
2. For projects located in California, or other projects where compliance to vertical wall shear testing is required, alternate moisture control techniques that omit integral water repellent may be used (e.g. use IWR within mortar; use post-applied breathable penetrating sealants or drainable film forming coatings; use High Range Water Reducer in grout).
3. Request evidence in writing of adequate head joint mortar bond to IWR-containing CMU for Properties-based mortars. Request in writing evidence of sufficient composite-action bond to IWR-containing CMU of Properties-based grout.
4. Single wythe walls rely upon a belt-and-suspenders approach to moisture control. Design typically will integrate flashing and weeps, integral water repellent, post-applied moisture control means and measures, sealants, movement joints, damp-checks, crack control, thermal bridging/condensate control, as well as soil elevation offsets and below-grade damp-proofing.

Codes and Standards References

Applicable References are found in Section III.

THE DETAILS PRESENTED IN THIS MANUAL ARE STANDARD DETAILS. DESIGNERS SHOULD MAKE SITE SPECIFIC INVESTIGATIONS TO DETERMINE ACTUAL DESIGN REQUIREMENTS, WHICH MAY VARY.

CPG IS NOT RESPONSIBLE FOR USES OF THIS INFORMATION BY THIRD PARTIES, AND DOES NOT WARRANT THE FITNESS OR SUITABILITY OF THIS INFORMATION FOR ANY PURPOSE. PERSONS MAKING USE OF THIS INFORMATION DO SO AT THEIR OWN RISK.

THESE STANDARD DETAILS ARE MEANT TO ILLUSTRATE GENERAL PRINCIPLES THAT MAY BE HELPFUL, HOWEVER, FINAL DESIGN AND CONSTRUCTION SHOULD BE BASED ON ACTUAL SITE CONDITIONS AND APPLICABLE LOCAL CODE AND STANDARDS. MANY SITE OR LOCAL CONDITIONS MAY REQUIRE SPECIFIC ADDITIONAL DESIGN CONSIDERATIONS. SUCH CONDITIONS MAY INCLUDE SEISMIC ACTIVITY, LOCAL CLIMATE, WIND LOAD AND STORM CONDITIONS (INCLUDING LIKELIHOOD OF TORNADO OR HURRICANE CONDITIONS), SITE SOILS AND DRAINAGE CONSIDERATIONS, AND A VARIETY OF OTHER FACTORS THAT MAY IMPACT BUILDING PERFORMANCE ON A PARTICULAR SITE.



Figure 42. HI-R Plank-Bearing Wall Partially Grouted

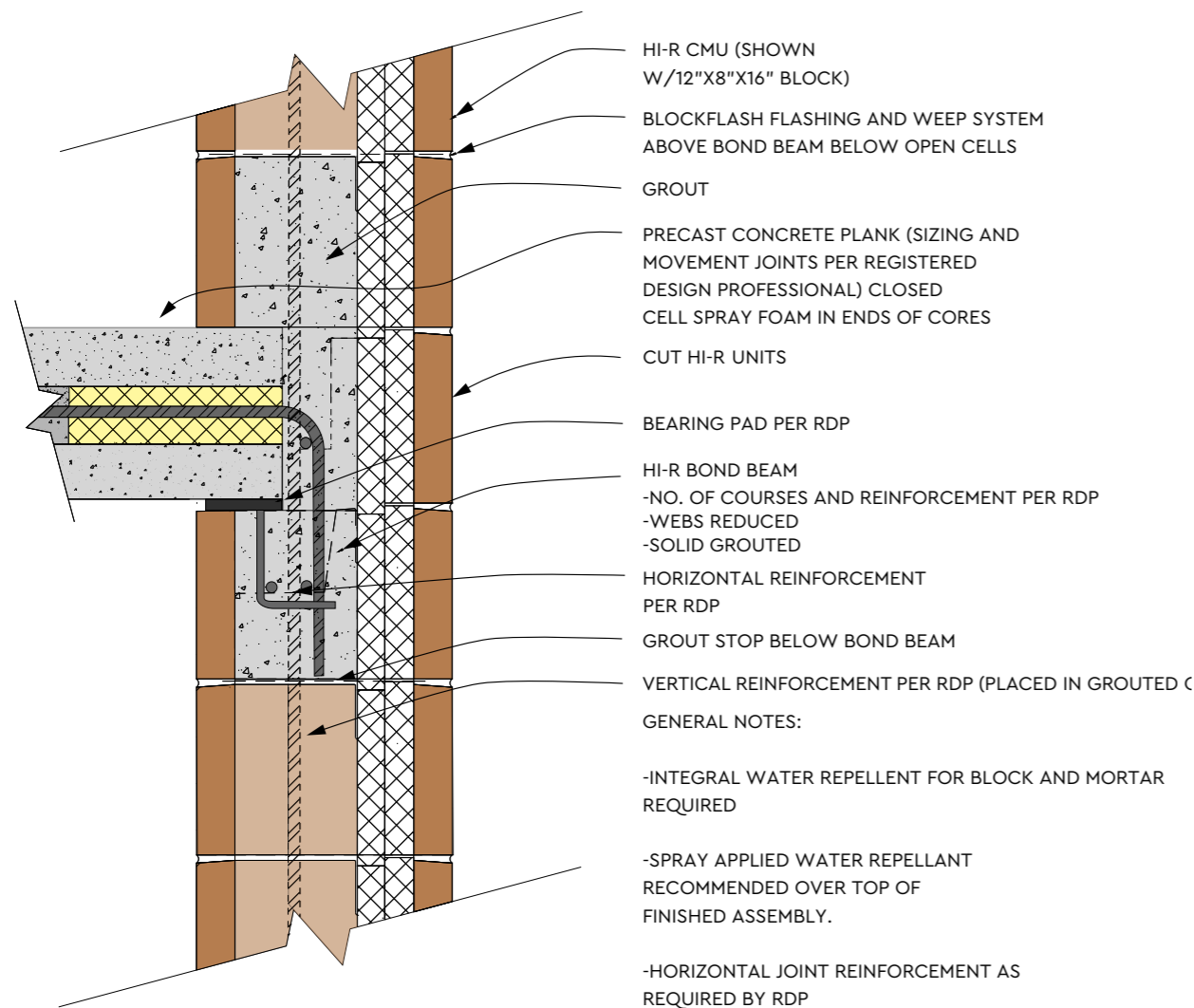

Notes:

1. This detail depicts a partially grouted wall. HI-R walls may be built either fully or partially grouted, while the HI-R-H products are fully grouted only. Fully grouting masonry walls is a cost-effective alternative to partially grouted walls. In many areas of the country where seismic design considerations are important, highly reinforced and fully grouted masonry is the preferred solution. Fully grouted walls do not require flashing at bond beam locations, and meet Code air barrier requirements.
2. For projects located in California, or other projects where compliance to vertical wall shear testing is required, alternate moisture control techniques that omit integral water repellent may be used (e.g. use IWR within mortar; use post-applied breathable penetrating sealants or drainable film forming coatings; use High Range Water Reducer in grout).
3. Request evidence in writing of adequate head joint mortar bond to IWR-containing CMU for Properties-based mortars. Request in writing evidence of sufficient composite-action bond to IWR-containing CMU of Properties-based grout.
4. Single wythe walls rely upon a belt-and-suspenders approach to moisture control. Design typically will integrate flashing and weeps, integral water repellent, post-applied moisture control means and measures, sealants, movement joints, damp-checks, crack control, thermal bridging/condensate control, as well as soil elevation offsets and below-grade damp-proofing.

Codes and Standards References

Applicable References are found in Section III.

THE DETAILS PRESENTED IN THIS MANUAL ARE STANDARD DETAILS. DESIGNERS SHOULD MAKE SITE SPECIFIC INVESTIGATIONS TO DETERMINE ACTUAL DESIGN REQUIREMENTS, WHICH MAY VARY.

CPG IS NOT RESPONSIBLE FOR USES OF THIS INFORMATION BY THIRD PARTIES, AND DOES NOT WARRANT THE FITNESS OR SUITABILITY OF THIS INFORMATION FOR ANY PURPOSE. PERSONS MAKING USE OF THIS INFORMATION DO SO AT THEIR OWN RISK.

THESE STANDARD DETAILS ARE MEANT TO ILLUSTRATE GENERAL PRINCIPLES THAT MAY BE HELPFUL, HOWEVER, FINAL DESIGN AND CONSTRUCTION SHOULD BE BASED ON ACTUAL SITE CONDITIONS AND APPLICABLE LOCAL CODE AND STANDARDS. MANY SITE OR LOCAL CONDITIONS MAY REQUIRE SPECIFIC ADDITIONAL DESIGN CONSIDERATIONS. SUCH CONDITIONS MAY INCLUDE SEISMIC ACTIVITY, LOCAL CLIMATE, WIND LOAD AND STORM CONDITIONS (INCLUDING LIKELIHOOD OF TORNADO OR HURRICANE CONDITIONS), SITE SOILS AND DRAINAGE CONSIDERATIONS, AND A VARIETY OF OTHER FACTORS THAT MAY IMPACT BUILDING PERFORMANCE ON A PARTICULAR SITE.



Figure 43. HI-R Plank at Non-Bearing Wall Partially Grouted

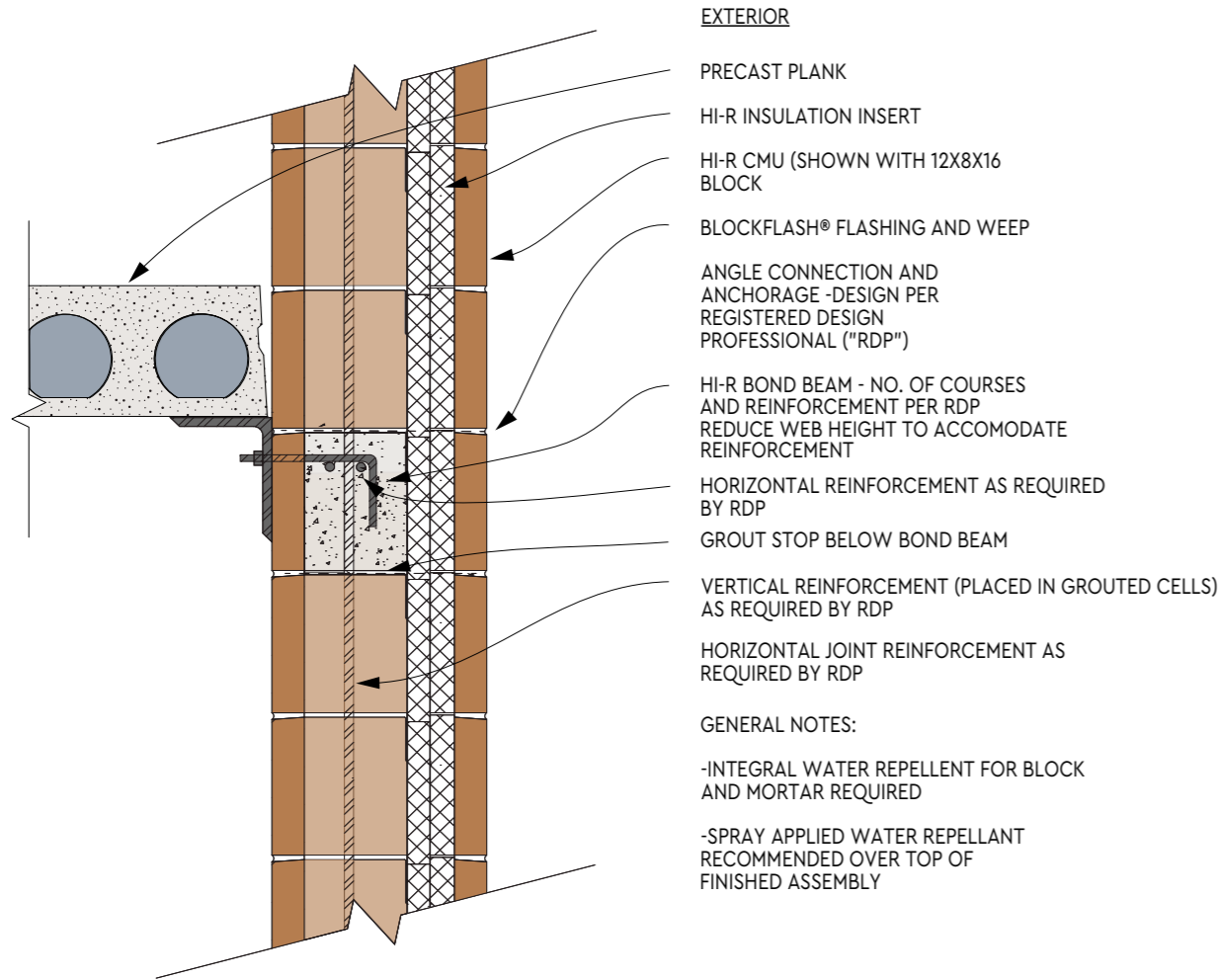

Notes:

1. This detail depicts a partially grouted wall. HI-R walls may be built either fully or partially grouted, while the HI-R-H products are fully grouted only. Fully grouting masonry walls is a cost-effective alternative to partially grouted walls. In many areas of the country where seismic design considerations are important, highly reinforced and fully grouted masonry is the preferred solution. Fully grouted walls do not require flashing at bond beam locations, and meet Code air barrier requirements.
2. For projects located in California, or other projects where compliance to vertical wall shear testing is required, alternate moisture control techniques that omit integral water repellent may be used (e.g. use IWR within mortar; use post-applied breathable penetrating sealants or drainable film forming coatings; use High Range Water Reducer in grout).
3. Request evidence in writing of adequate head joint mortar bond to IWR-containing CMU for Properties-based mortars. Request in writing evidence of sufficient composite-action bond to IWR-containing CMU of Properties-based grout.
4. Single wythe walls rely upon a belt-and-suspenders approach to moisture control. Design typically will integrate flashing and weeps, integral water repellent, post-applied moisture control means and measures, sealants, movement joints, damp-checks, crack control, thermal bridging/condensate control, as well as soil elevation offsets and below-grade damp-proofing.

Codes and Standards References

Applicable References are found in Section III.

THE DETAILS PRESENTED IN THIS MANUAL ARE STANDARD DETAILS. DESIGNERS SHOULD MAKE SITE SPECIFIC INVESTIGATIONS TO DETERMINE ACTUAL DESIGN REQUIREMENTS, WHICH MAY VARY.

CPG IS NOT RESPONSIBLE FOR USES OF THIS INFORMATION BY THIRD PARTIES, AND DOES NOT WARRANT THE FITNESS OR SUITABILITY OF THIS INFORMATION FOR ANY PURPOSE. PERSONS MAKING USE OF THIS INFORMATION DO SO AT THEIR OWN RISK.

THESE STANDARD DETAILS ARE MEANT TO ILLUSTRATE GENERAL PRINCIPLES THAT MAY BE HELPFUL, HOWEVER, FINAL DESIGN AND CONSTRUCTION SHOULD BE BASED ON ACTUAL SITE CONDITIONS AND APPLICABLE LOCAL CODE AND STANDARDS. MANY SITE OR LOCAL CONDITIONS MAY REQUIRE SPECIFIC ADDITIONAL DESIGN CONSIDERATIONS. SUCH CONDITIONS MAY INCLUDE SEISMIC ACTIVITY, LOCAL CLIMATE, WIND LOAD AND STORM CONDITIONS (INCLUDING LIKELIHOOD OF TORNADO OR HURRICANE CONDITIONS), SITE SOILS AND DRAINAGE CONSIDERATIONS, AND A VARIETY OF OTHER FACTORS THAT MAY IMPACT BUILDING PERFORMANCE ON A PARTICULAR SITE.



Figure 44. HI-R HALF HIGH Plank at Bearing Wall Partially Grouted

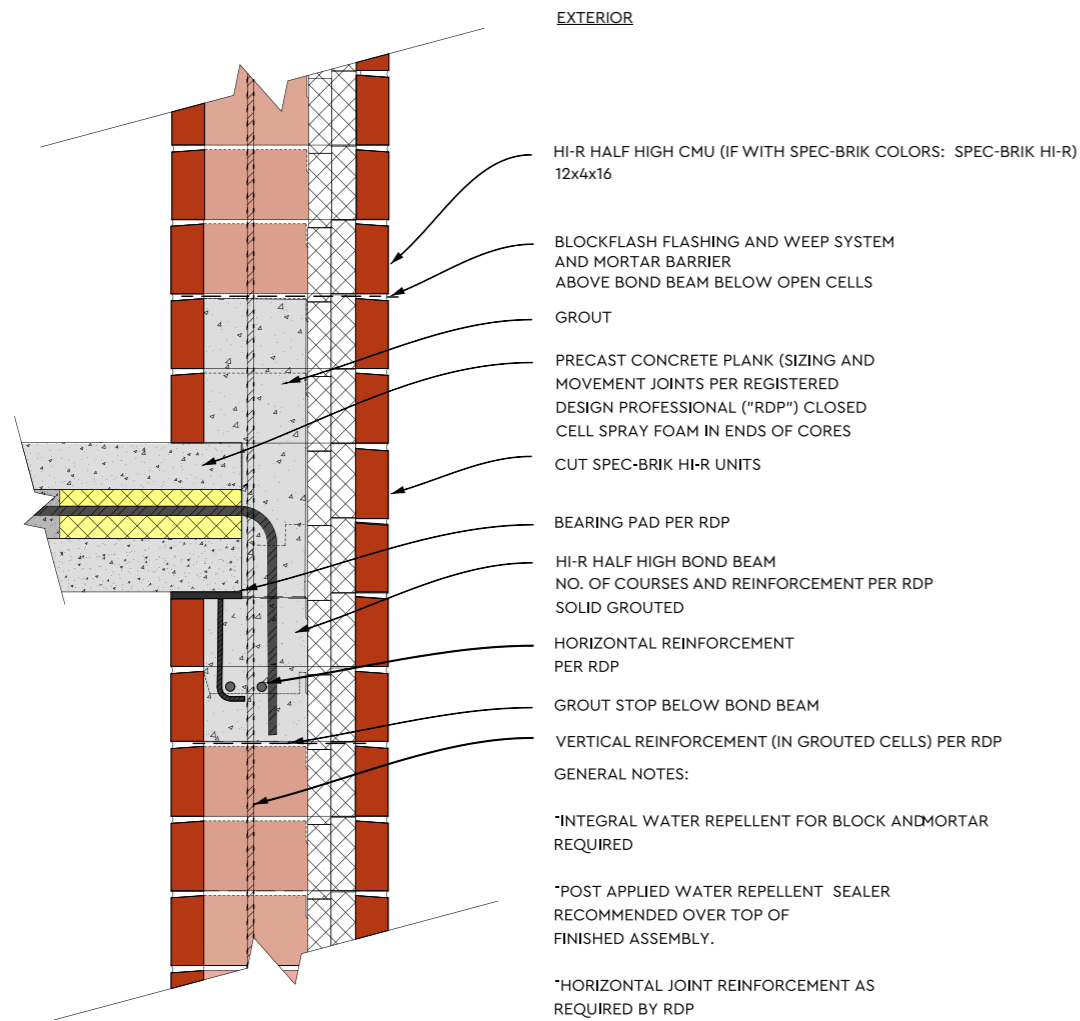

Notes:

1. This detail depicts a partially grouted wall. HI-R walls may be built either fully or partially grouted, while the HI-R-H products are fully grouted only. Fully grouting masonry walls is a cost-effective alternative to partially grouted walls. In many areas of the country where seismic design considerations are important, highly reinforced and fully grouted masonry is the preferred solution. Fully grouted walls do not require flashing at bond beam locations, and meet Code air barrier requirements.
2. For projects located in California, or other projects where compliance to vertical wall shear testing is required, alternate moisture control techniques that omit integral water repellent may be used (e.g. use IWR within mortar; use post-applied breathable penetrating sealants or drainable film forming coatings; use High Range Water Reducer in grout).
3. Request evidence in writing of adequate head joint mortar bond to IWR-containing CMU for Properties-based mortars. Request in writing evidence of sufficient composite-action bond to IWR-containing CMU of Properties-based grout.
4. Single wythe walls rely upon a belt-and-suspenders approach to moisture control. Design typically will integrate flashing and weeps, integral water repellent, post-applied moisture control means and measures, sealants, movement joints, damp-checks, crack control, thermal bridging/condensate control, as well as soil elevation offsets and below-grade damp-proofing.

Codes and Standards References

Applicable References are found in Section III.

THE DETAILS PRESENTED IN THIS MANUAL ARE STANDARD DETAILS. DESIGNERS SHOULD MAKE SITE SPECIFIC INVESTIGATIONS TO DETERMINE ACTUAL DESIGN REQUIREMENTS, WHICH MAY VARY.

CPG IS NOT RESPONSIBLE FOR USES OF THIS INFORMATION BY THIRD PARTIES, AND DOES NOT WARRANT THE FITNESS OR SUITABILITY OF THIS INFORMATION FOR ANY PURPOSE. PERSONS MAKING USE OF THIS INFORMATION DO SO AT THEIR OWN RISK.

THESE STANDARD DETAILS ARE MEANT TO ILLUSTRATE GENERAL PRINCIPLES THAT MAY BE HELPFUL, HOWEVER, FINAL DESIGN AND CONSTRUCTION SHOULD BE BASED ON ACTUAL SITE CONDITIONS AND APPLICABLE LOCAL CODE AND STANDARDS. MANY SITE OR LOCAL CONDITIONS MAY REQUIRE SPECIFIC ADDITIONAL DESIGN CONSIDERATIONS. SUCH CONDITIONS MAY INCLUDE SEISMIC ACTIVITY, LOCAL CLIMATE, WIND LOAD AND STORM CONDITIONS (INCLUDING LIKELIHOOD OF TORNADO OR HURRICANE CONDITIONS), SITE SOILS AND DRAINAGE CONSIDERATIONS, AND A VARIETY OF OTHER FACTORS THAT MAY IMPACT BUILDING PERFORMANCE ON A PARTICULAR SITE.



Figure 45. HI-R Half High Bearing Wall

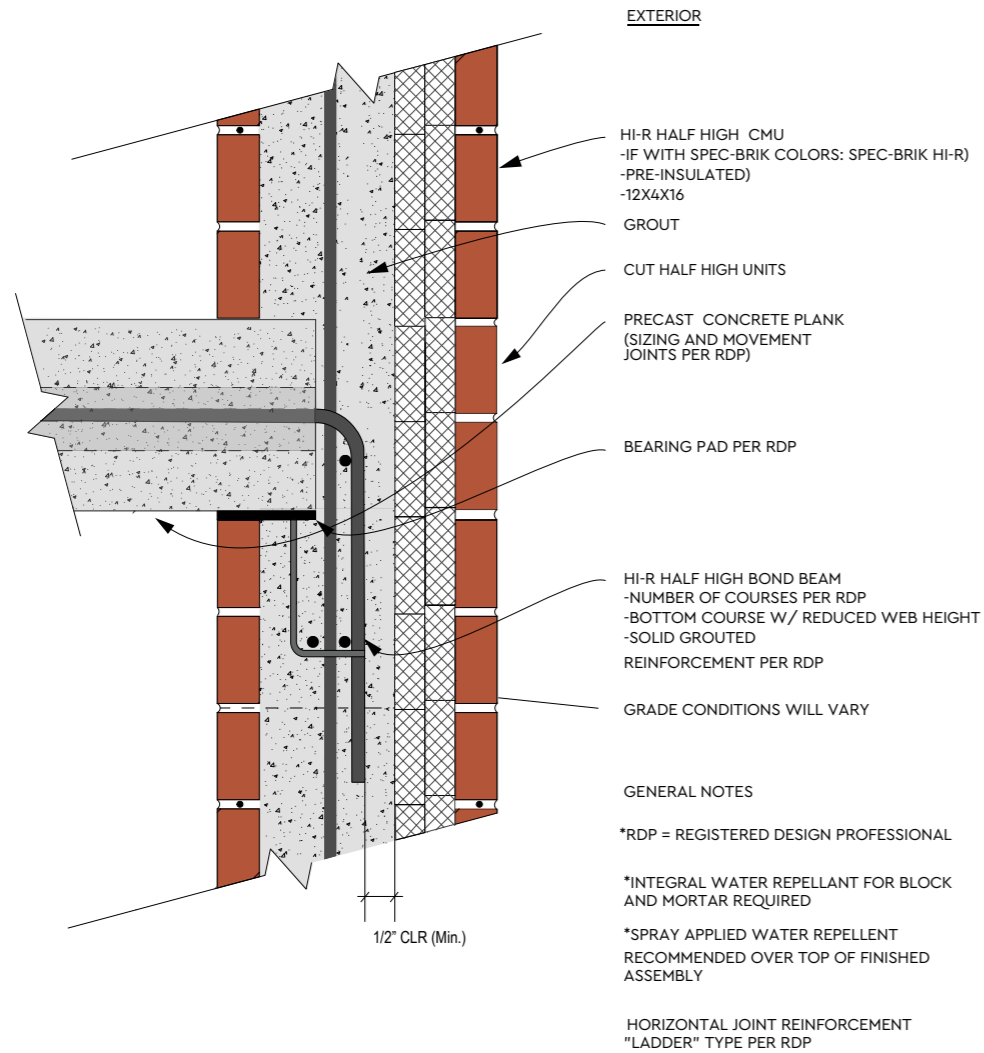

Notes:

1. This detail depicts a fully grouted wall. HI-R walls may be built either fully or partially grouted, while the HI-R-H products are fully grouted only. Fully grouting masonry walls is a cost-effective alternative to partially grouted walls. In many areas of the country where seismic design considerations are important, highly reinforced and fully grouted masonry is the preferred solution. Fully grouted walls do not require flashing at bond beam locations, and meet Code air barrier requirements.
2. For projects located in California, or other projects where compliance to vertical wall shear testing is required, alternate moisture control techniques that omit integral water repellent may be used (e.g. use IWR within mortar; use post-applied breathable penetrating sealants or drainable film forming coatings; use High Range Water Reducer in grout).
3. Request evidence in writing of adequate head joint mortar bond to IWR-containing CMU for Properties-based mortars. Request in writing evidence of sufficient composite-action bond to IWR-containing CMU of Properties-based grout.
4. Single wythe walls rely upon a belt-and-suspenders approach to moisture control. Design typically will integrate flashing and weeps, integral water repellent, post-applied moisture control means and measures, sealants, movement joints, damp-checks, crack control, thermal bridging/condensate control, as well as soil elevation offsets and below-grade damp-proofing.

Codes and Standards References

Applicable References are found in Section III.

THE DETAILS PRESENTED IN THIS MANUAL ARE STANDARD DETAILS. DESIGNERS SHOULD MAKE SITE SPECIFIC INVESTIGATIONS TO DETERMINE ACTUAL DESIGN REQUIREMENTS, WHICH MAY VARY.

CPG IS NOT RESPONSIBLE FOR USES OF THIS INFORMATION BY THIRD PARTIES, AND DOES NOT WARRANT THE FITNESS OR SUITABILITY OF THIS INFORMATION FOR ANY PURPOSE. PERSONS MAKING USE OF THIS INFORMATION DO SO AT THEIR OWN RISK.

THESE STANDARD DETAILS ARE MEANT TO ILLUSTRATE GENERAL PRINCIPLES THAT MAY BE HELPFUL, HOWEVER, FINAL DESIGN AND CONSTRUCTION SHOULD BE BASED ON ACTUAL SITE CONDITIONS AND APPLICABLE LOCAL CODE AND STANDARDS. MANY SITE OR LOCAL CONDITIONS MAY REQUIRE SPECIFIC ADDITIONAL DESIGN CONSIDERATIONS. SUCH CONDITIONS MAY INCLUDE SEISMIC ACTIVITY, LOCAL CLIMATE, WIND LOAD AND STORM CONDITIONS (INCLUDING LIKELIHOOD OF TORNADO OR HURRICANE CONDITIONS), SITE SOILS AND DRAINAGE CONSIDERATIONS, AND A VARIETY OF OTHER FACTORS THAT MAY IMPACT BUILDING PERFORMANCE ON A PARTICULAR SITE.



Figure 46. HI-R Half High Plank at Non-Bearing Wall Fully Grouted

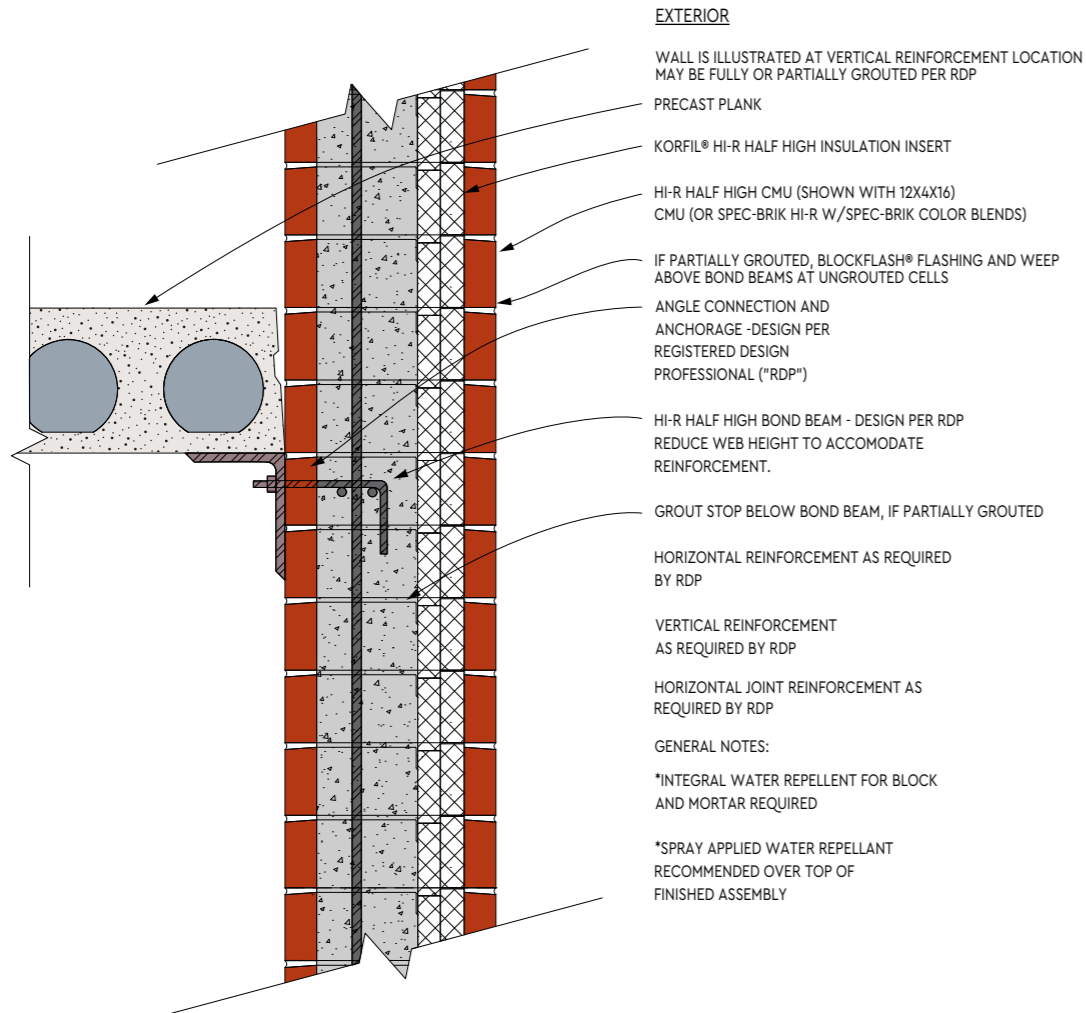

Notes:

1. This detail depicts a fully grouted wall. HI-R walls may be built either fully or partially grouted, while the HI-R-H products are fully grouted only. Fully grouting masonry walls is a cost-effective alternative to partially grouted walls. In many areas of the country where seismic design considerations are important, highly reinforced and fully grouted masonry is the preferred solution. Fully grouted walls do not require flashing at bond beam locations, and meet Code air barrier requirements.
2. For projects located in California, or other projects where compliance to vertical wall shear testing is required, alternate moisture control techniques that omit integral water repellent may be used (e.g. use IWR within mortar; use post-applied breathable penetrating sealants or drainable film forming coatings; use High Range Water Reducer in grout).
3. Request evidence in writing of adequate head joint mortar bond to IWR-containing CMU for Properties-based mortars. Request in writing evidence of sufficient composite-action bond to IWR-containing CMU of Properties-based grout.
4. Single wythe walls rely upon a belt-and-suspenders approach to moisture control. Design typically will integrate flashing and weeps, integral water repellent, post-applied moisture control means and measures, sealants, movement joints, damp-checks, crack control, thermal bridging/condensate control, as well as soil elevation offsets and below-grade damp-proofing.

Codes and Standards References

Applicable References are found in Section III.

THE DETAILS PRESENTED IN THIS MANUAL ARE STANDARD DETAILS. DESIGNERS SHOULD MAKE SITE SPECIFIC INVESTIGATIONS TO DETERMINE ACTUAL DESIGN REQUIREMENTS, WHICH MAY VARY.

CPG IS NOT RESPONSIBLE FOR USES OF THIS INFORMATION BY THIRD PARTIES, AND DOES NOT WARRANT THE FITNESS OR SUITABILITY OF THIS INFORMATION FOR ANY PURPOSE. PERSONS MAKING USE OF THIS INFORMATION DO SO AT THEIR OWN RISK.

THESE STANDARD DETAILS ARE MEANT TO ILLUSTRATE GENERAL PRINCIPLES THAT MAY BE HELPFUL, HOWEVER, FINAL DESIGN AND CONSTRUCTION SHOULD BE BASED ON ACTUAL SITE CONDITIONS AND APPLICABLE LOCAL CODE AND STANDARDS. MANY SITE OR LOCAL CONDITIONS MAY REQUIRE SPECIFIC ADDITIONAL DESIGN CONSIDERATIONS. SUCH CONDITIONS MAY INCLUDE SEISMIC ACTIVITY, LOCAL CLIMATE, WIND LOAD AND STORM CONDITIONS (INCLUDING LIKELIHOOD OF TORNADO OR HURRICANE CONDITIONS), SITE SOILS AND DRAINAGE CONSIDERATIONS, AND A VARIETY OF OTHER FACTORS THAT MAY IMPACT BUILDING PERFORMANCE ON A PARTICULAR SITE.



Figure 47. HI-R-H Plank at Bearing Wall Fully Grouted

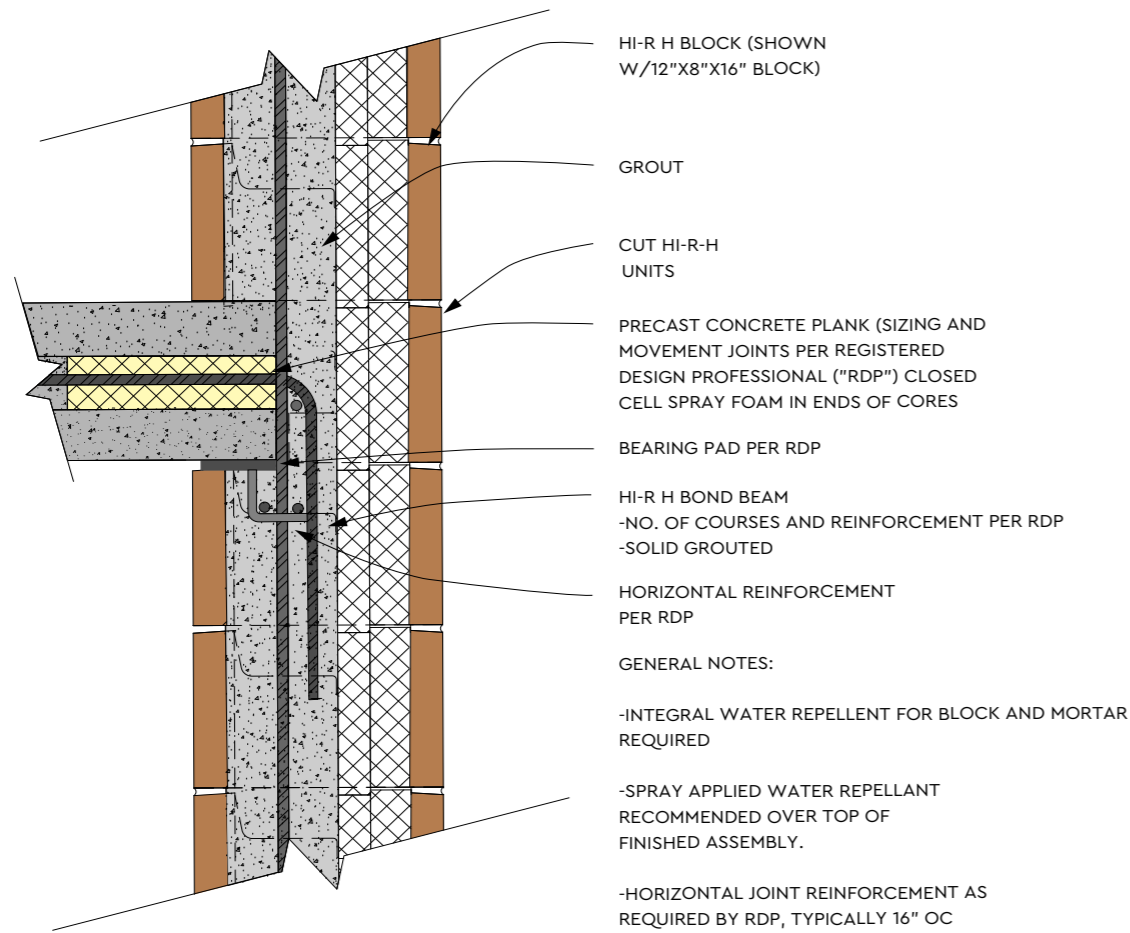

Notes:

1. This detail depicts a fully grouted wall. HI-R walls may be built either fully or partially grouted, while the HI-R-H products are fully grouted only. Fully grouting masonry walls is a cost-effective alternative to partially grouted walls. In many areas of the country where seismic design considerations are important, highly reinforced and fully grouted masonry is the preferred solution. Fully grouted walls do not require flashing at bond beam locations, and meet Code air barrier requirements.
2. For projects located in California, or other projects where compliance to vertical wall shear testing is required, alternate moisture control techniques that omit integral water repellent may be used (e.g. use IWR within mortar; use post-applied breathable penetrating sealants or drainable film forming coatings; use High Range Water Reducer in grout).
3. Request evidence in writing of adequate head joint mortar bond to IWR-containing CMU for Properties-based mortars. Request in writing evidence of sufficient composite-action bond to IWR-containing CMU of Properties-based grout.
4. Single wythe walls rely upon a belt-and-suspenders approach to moisture control. Design typically will integrate flashing and weeps, integral water repellent, post-applied moisture control means and measures, sealants, movement joints, damp-checks, crack control, thermal bridging/condensate control, as well as soil elevation offsets and below-grade damp-proofing.

Codes and Standards References

Applicable References are found in Section III.

THE DETAILS PRESENTED IN THIS MANUAL ARE STANDARD DETAILS. DESIGNERS SHOULD MAKE SITE SPECIFIC INVESTIGATIONS TO DETERMINE ACTUAL DESIGN REQUIREMENTS, WHICH MAY VARY.

CPG IS NOT RESPONSIBLE FOR USES OF THIS INFORMATION BY THIRD PARTIES, AND DOES NOT WARRANT THE FITNESS OR SUITABILITY OF THIS INFORMATION FOR ANY PURPOSE. PERSONS MAKING USE OF THIS INFORMATION DO SO AT THEIR OWN RISK.

THESE STANDARD DETAILS ARE MEANT TO ILLUSTRATE GENERAL PRINCIPLES THAT MAY BE HELPFUL, HOWEVER, FINAL DESIGN AND CONSTRUCTION SHOULD BE BASED ON ACTUAL SITE CONDITIONS AND APPLICABLE LOCAL CODE AND STANDARDS. MANY SITE OR LOCAL CONDITIONS MAY REQUIRE SPECIFIC ADDITIONAL DESIGN CONSIDERATIONS. SUCH CONDITIONS MAY INCLUDE SEISMIC ACTIVITY, LOCAL CLIMATE, WIND LOAD AND STORM CONDITIONS (INCLUDING LIKELIHOOD OF TORNADO OR HURRICANE CONDITIONS), SITE SOILS AND DRAINAGE CONSIDERATIONS, AND A VARIETY OF OTHER FACTORS THAT MAY IMPACT BUILDING PERFORMANCE ON A PARTICULAR SITE.



Figure 48. HI-R-H Plank at Non-Bearing Wall Fully Grouted

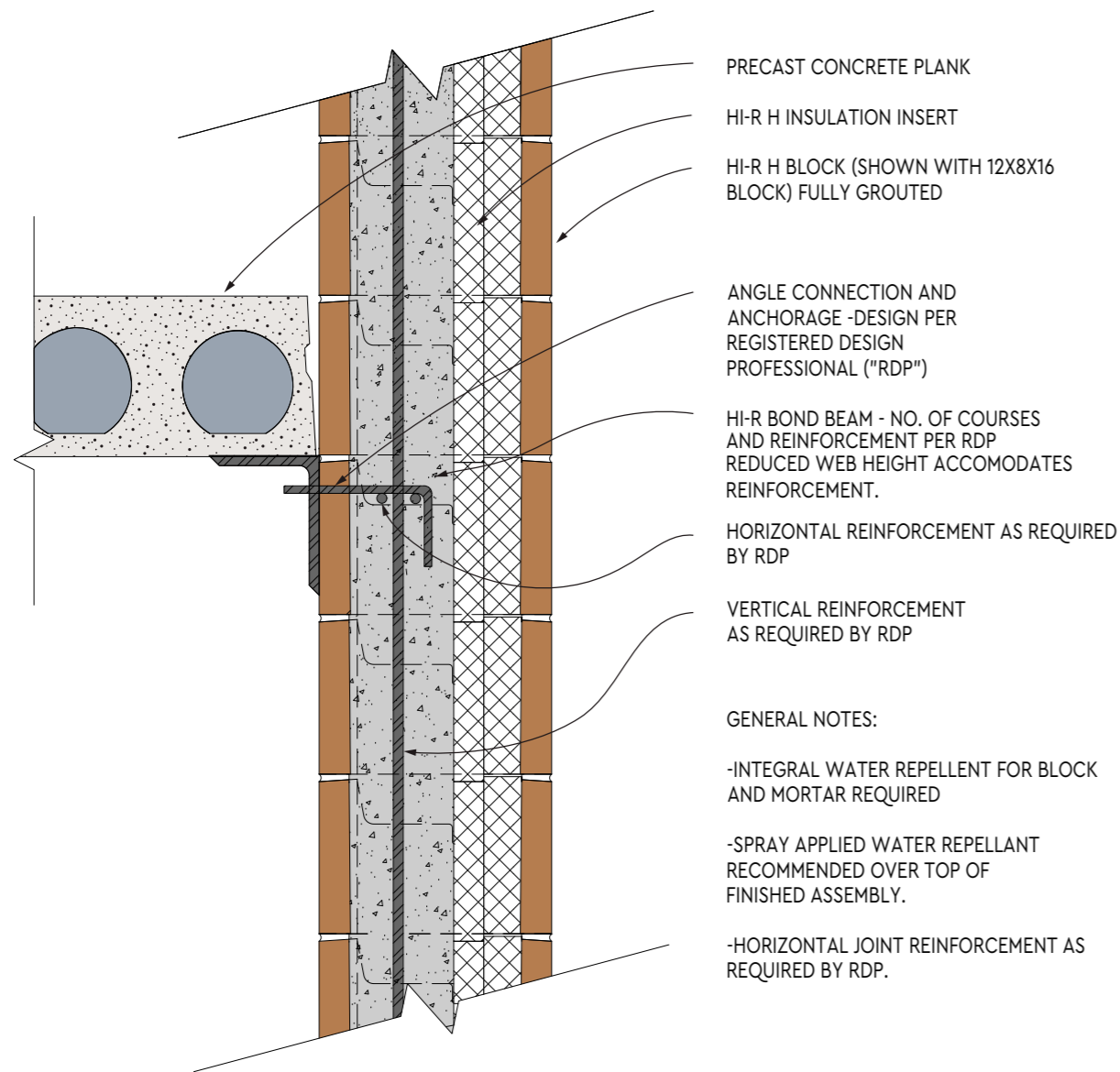

Notes:

1. This detail depicts a fully grouted wall. HI-R walls may be built either fully or partially grouted, while the HI-R-H products are fully grouted only. Fully grouting masonry walls is a cost-effective alternative to partially grouted walls. In many areas of the country where seismic design considerations are important, highly reinforced and fully grouted masonry is the preferred solution. Fully grouted walls do not require flashing at bond beam locations, and meet Code air barrier requirements.
2. For projects located in California, or other projects where compliance to vertical wall shear testing is required, alternate moisture control techniques that omit integral water repellent may be used (e.g. use IWR within mortar; use post-applied breathable penetrating sealants or drainable film forming coatings; use High Range Water Reducer in grout).
3. Request evidence in writing of adequate head joint mortar bond to IWR-containing CMU for Properties-based mortars. Request in writing evidence of sufficient composite-action bond to IWR-containing CMU of Properties-based grout.
4. Single wythe walls rely upon a belt-and-suspenders approach to moisture control. Design typically will integrate flashing and weeps, integral water repellent, post-applied moisture control means and measures, sealants, movement joints, damp-checks, crack control, thermal bridging/condensate control, as well as soil elevation offsets and below-grade damp-proofing.

Codes and Standards References

Applicable References are found in Section III.

THE DETAILS PRESENTED IN THIS MANUAL ARE STANDARD DETAILS. DESIGNERS SHOULD MAKE SITE SPECIFIC INVESTIGATIONS TO DETERMINE ACTUAL DESIGN REQUIREMENTS, WHICH MAY VARY.

CPG IS NOT RESPONSIBLE FOR USES OF THIS INFORMATION BY THIRD PARTIES, AND DOES NOT WARRANT THE FITNESS OR SUITABILITY OF THIS INFORMATION FOR ANY PURPOSE. PERSONS MAKING USE OF THIS INFORMATION DO SO AT THEIR OWN RISK.

THESE STANDARD DETAILS ARE MEANT TO ILLUSTRATE GENERAL PRINCIPLES THAT MAY BE HELPFUL, HOWEVER, FINAL DESIGN AND CONSTRUCTION SHOULD BE BASED ON ACTUAL SITE CONDITIONS AND APPLICABLE LOCAL CODE AND STANDARDS. MANY SITE OR LOCAL CONDITIONS MAY REQUIRE SPECIFIC ADDITIONAL DESIGN CONSIDERATIONS. SUCH CONDITIONS MAY INCLUDE SEISMIC ACTIVITY, LOCAL CLIMATE, WIND LOAD AND STORM CONDITIONS (INCLUDING LIKELIHOOD OF TORNADO OR HURRICANE CONDITIONS), SITE SOILS AND DRAINAGE CONSIDERATIONS, AND A VARIETY OF OTHER FACTORS THAT MAY IMPACT BUILDING PERFORMANCE ON A PARTICULAR SITE.



Figure 49. HI-R-H Half High Bearing Wall Plank

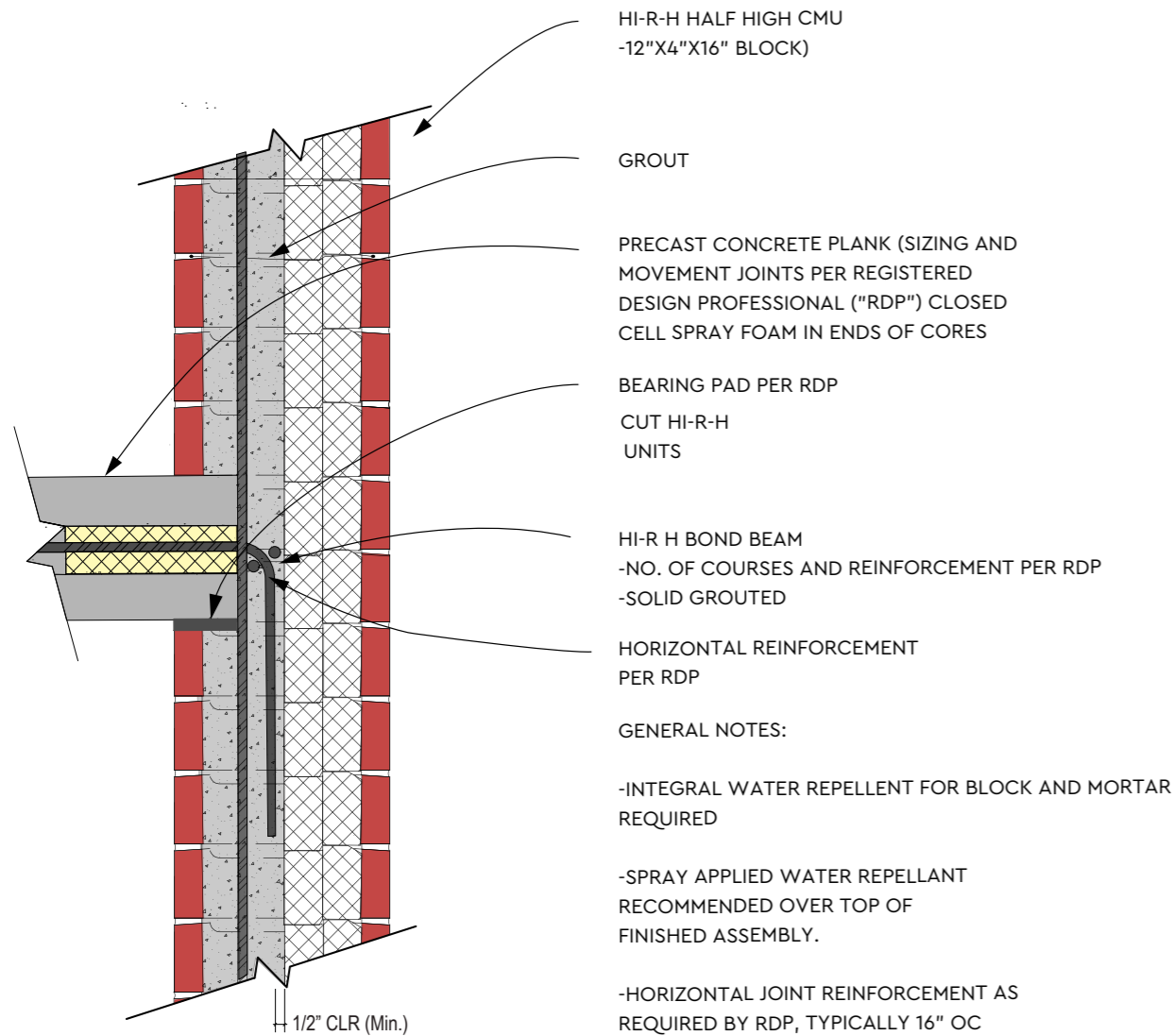

Notes:

1. This detail depicts a fully grouted wall. HI-R walls may be built either fully or partially grouted, while the HI-R-H products are fully grouted only. Fully grouting masonry walls is a cost-effective alternative to partially grouted walls. In many areas of the country where seismic design considerations are important, highly reinforced and fully grouted masonry is the preferred solution. Fully grouted walls do not require flashing at bond beam locations, and meet Code air barrier requirements.
2. For projects located in California, or other projects where compliance to vertical wall shear testing is required, alternate moisture control techniques that omit integral water repellent may be used (e.g. use IWR within mortar; use post-applied breathable penetrating sealants or drainable film forming coatings; use High Range Water Reducer in grout).
3. Request evidence in writing of adequate head joint mortar bond to IWR-containing CMU for Properties-based mortars. Request in writing evidence of sufficient composite-action bond to IWR-containing CMU of Properties-based grout.
4. Single wythe walls rely upon a belt-and-suspenders approach to moisture control. Design typically will integrate flashing and weeps, integral water repellent, post-applied moisture control means and measures, sealants, movement joints, damp-checks, crack control, thermal bridging/condensate control, as well as soil elevation offsets and below-grade damp-proofing.

Codes and Standards References

Applicable References are found in Section III.

THE DETAILS PRESENTED IN THIS MANUAL ARE STANDARD DETAILS. DESIGNERS SHOULD MAKE SITE SPECIFIC INVESTIGATIONS TO DETERMINE ACTUAL DESIGN REQUIREMENTS, WHICH MAY VARY.

CPG IS NOT RESPONSIBLE FOR USES OF THIS INFORMATION BY THIRD PARTIES, AND DOES NOT WARRANT THE FITNESS OR SUITABILITY OF THIS INFORMATION FOR ANY PURPOSE. PERSONS MAKING USE OF THIS INFORMATION DO SO AT THEIR OWN RISK.

THESE STANDARD DETAILS ARE MEANT TO ILLUSTRATE GENERAL PRINCIPLES THAT MAY BE HELPFUL, HOWEVER, FINAL DESIGN AND CONSTRUCTION SHOULD BE BASED ON ACTUAL SITE CONDITIONS AND APPLICABLE LOCAL CODE AND STANDARDS. MANY SITE OR LOCAL CONDITIONS MAY REQUIRE SPECIFIC ADDITIONAL DESIGN CONSIDERATIONS. SUCH CONDITIONS MAY INCLUDE SEISMIC ACTIVITY, LOCAL CLIMATE, WIND LOAD AND STORM CONDITIONS (INCLUDING LIKELIHOOD OF TORNADO OR HURRICANE CONDITIONS), SITE SOILS AND DRAINAGE CONSIDERATIONS, AND A VARIETY OF OTHER FACTORS THAT MAY IMPACT BUILDING PERFORMANCE ON A PARTICULAR SITE.

Figure 50. HI-R-H Half High Plank at Non-Bearing Wall Fully Grouted

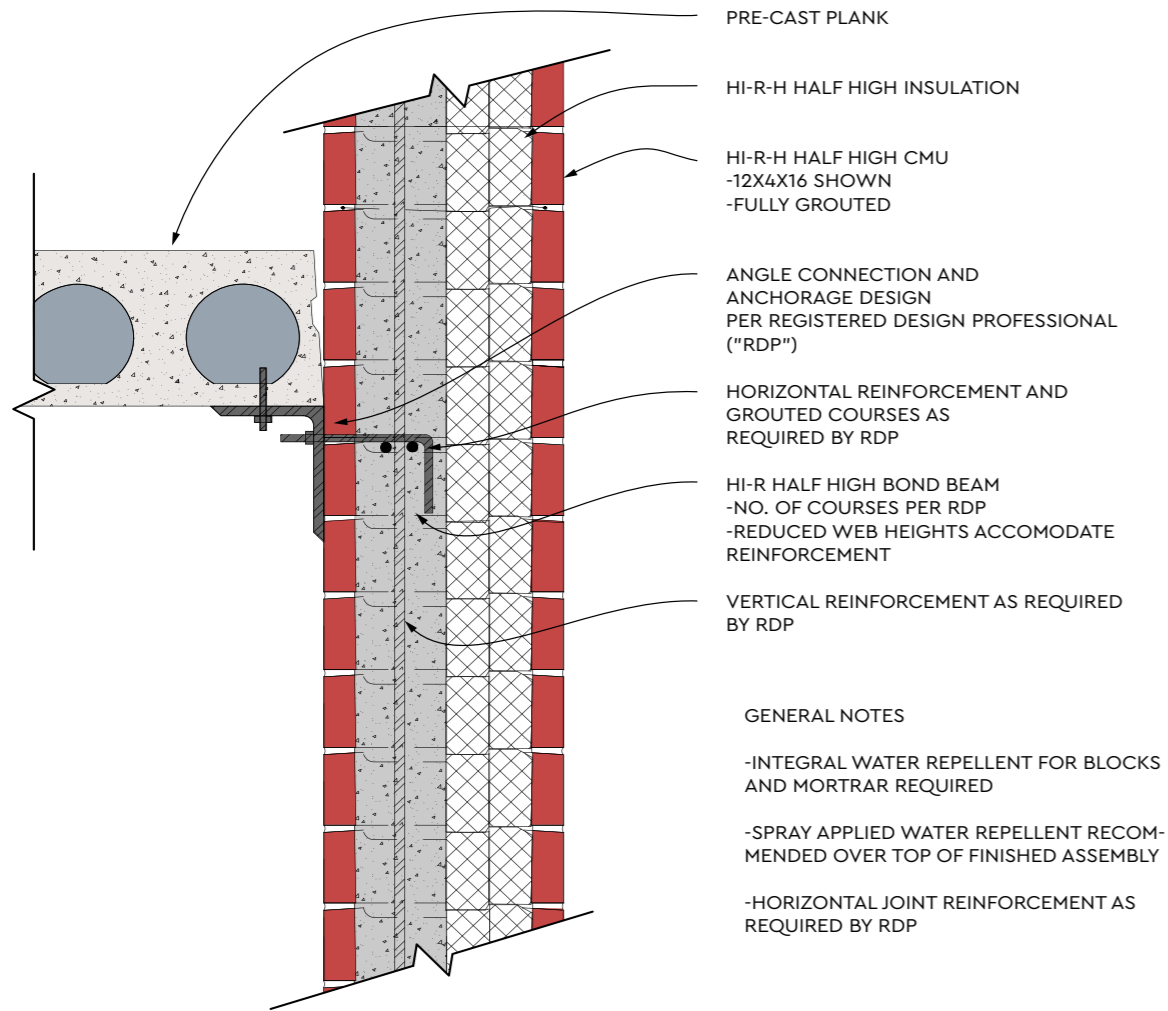

Notes:

1. This detail depicts a fully grouted wall. HI-R walls may be built either fully or partially grouted, while the HI-R-H products are fully grouted only. Fully grouting masonry walls is a cost-effective alternative to partially grouted walls. In many areas of the country where seismic design considerations are important, highly reinforced and fully grouted masonry is the preferred solution. Fully grouted walls do not require flashing at bond beam locations, and meet Code air barrier requirements.
2. For projects located in California, or other projects where compliance to vertical wall shear testing is required, alternate moisture control techniques that omit integral water repellent may be used (e.g. use IWR within mortar; use post-applied breathable penetrating sealants or drainable film forming coatings; use High Range Water Reducer in grout).
3. Request evidence in writing of adequate head joint mortar bond to IWR-containing CMU for Properties-based mortars. Request in writing evidence of sufficient composite-action bond to IWR-containing CMU of Properties-based grout.
4. Single wythe walls rely upon a belt-and-suspenders approach to moisture control. Design typically will integrate flashing and weeps, integral water repellent, post-applied moisture control means and measures, sealants, movement joints, damp-checks, crack control, thermal bridging/condensate control, as well as soil elevation offsets and below-grade damp-proofing.

Codes and Standards References

Applicable References are found in Section III.

THE DETAILS PRESENTED IN THIS MANUAL ARE STANDARD DETAILS. DESIGNERS SHOULD MAKE SITE SPECIFIC INVESTIGATIONS TO DETERMINE ACTUAL DESIGN REQUIREMENTS, WHICH MAY VARY.

CPG IS NOT RESPONSIBLE FOR USES OF THIS INFORMATION BY THIRD PARTIES, AND DOES NOT WARRANT THE FITNESS OR SUITABILITY OF THIS INFORMATION FOR ANY PURPOSE. PERSONS MAKING USE OF THIS INFORMATION DO SO AT THEIR OWN RISK.

THESE STANDARD DETAILS ARE MEANT TO ILLUSTRATE GENERAL PRINCIPLES THAT MAY BE HELPFUL, HOWEVER, FINAL DESIGN AND CONSTRUCTION SHOULD BE BASED ON ACTUAL SITE CONDITIONS AND APPLICABLE LOCAL CODE AND STANDARDS. MANY SITE OR LOCAL CONDITIONS MAY REQUIRE SPECIFIC ADDITIONAL DESIGN CONSIDERATIONS. SUCH CONDITIONS MAY INCLUDE SEISMIC ACTIVITY, LOCAL CLIMATE, WIND LOAD AND STORM CONDITIONS (INCLUDING LIKELIHOOD OF TORNADO OR HURRICANE CONDITIONS), SITE SOILS AND DRAINAGE CONSIDERATIONS, AND A VARIETY OF OTHER FACTORS THAT MAY IMPACT BUILDING PERFORMANCE ON A PARTICULAR SITE.

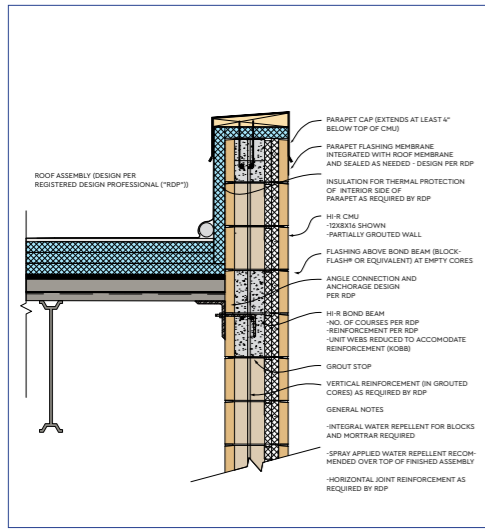

Figure 51. Roof and Parapet HI-R Partially Grouted (Non-Bearing)

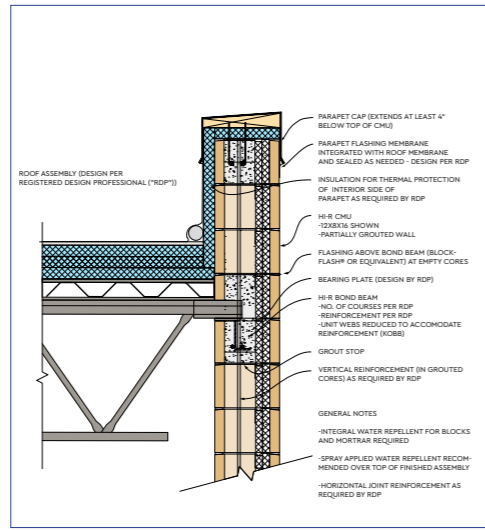

Figure 52. Roof and Parapet HI-R Partially Grouted (Bearing)

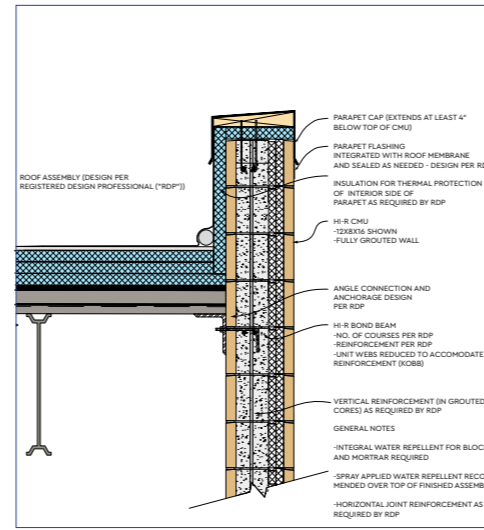

Figure 53. Roof and Parapet HI-R Fully Grouted (Non-Bearing)

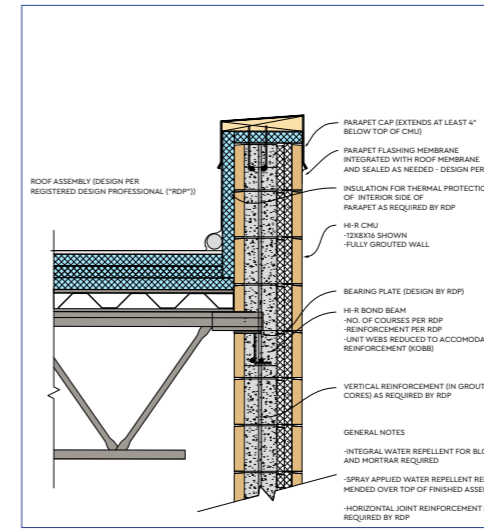

Figure 54. Roof and Parapet HI-R Fully Grouted (Bearing)

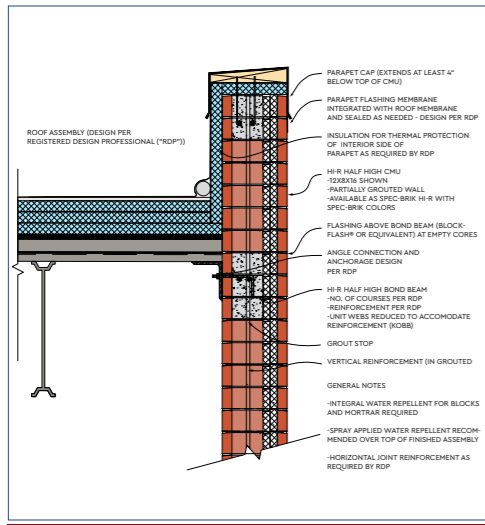

Figure 55. Roof and Parapet HI-R HH Partially Grouted (Non-Bearing)

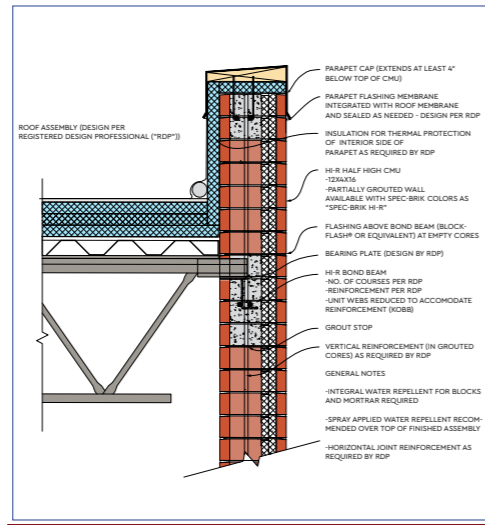

Figure 56. Roof and Parapet HI-R HH Partially Grouted (Bearing)

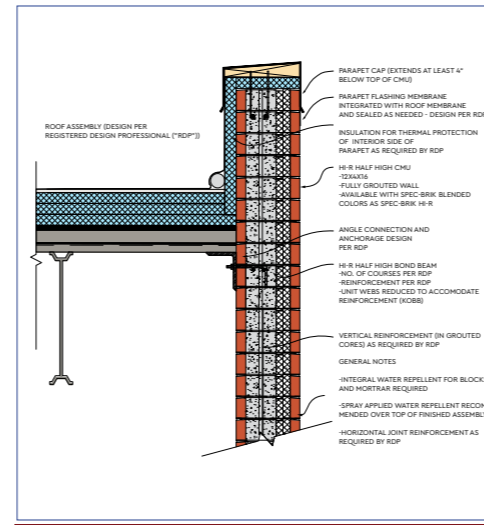

Figure 57. Roof and Parapet HI-R HH Fully Grouted (Non-Bearing)

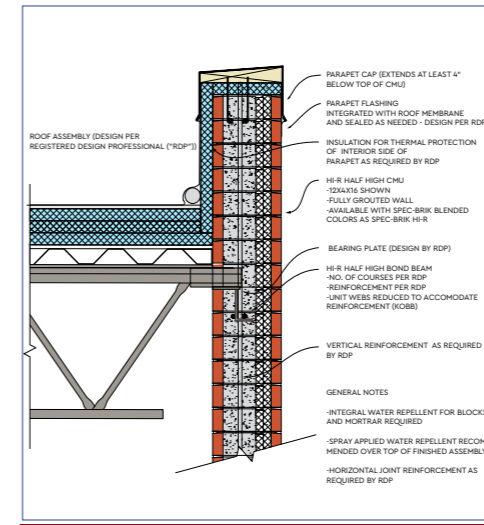

Figure 58. Roof and Parapet HI-R HH Fully Grouted (Bearing)

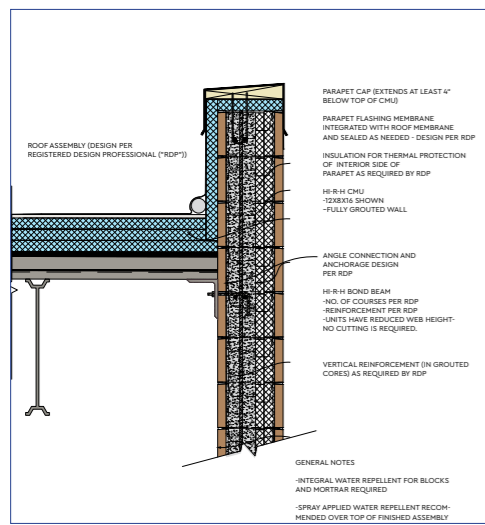

Figure 59. Roof and Parapet HI-R-H Fully Grouted (Non-Bearing)

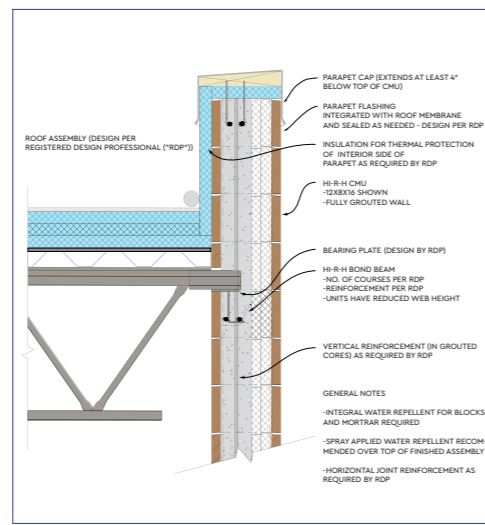

Figure 60. Roof and Parapet HI-R-H Fully Grouted (Bearing)

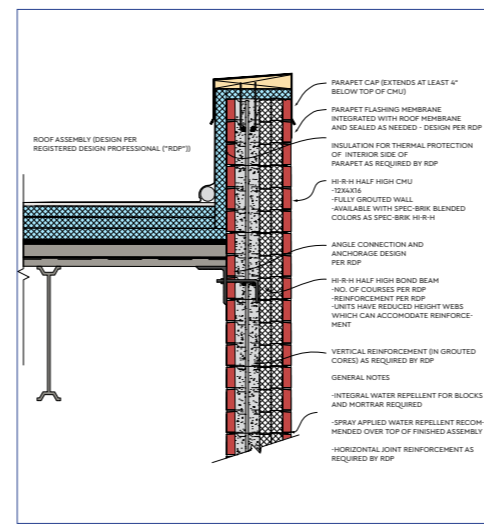

Figure 61. Roof and Parapet HI-R-H HH Fully Grouted (Non-Bearing)

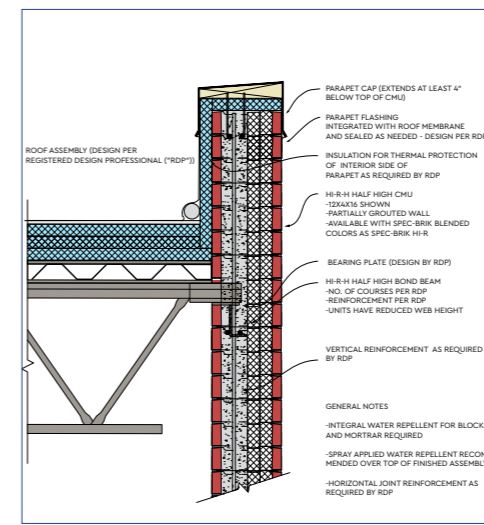

Figure 62. Roof and Parapet HI-R-H HH Fully Grouted (Bearing)

Click on drawings to enlarge

Table of Contents	
Figure 51. Roof and Parapet HI-R Partially Grouted (Non-Bearing)	1
Figure 52. Roof and Parapet HI-R Partially Grouted (Bearing)	1
Figure 53. Roof and Parapet HI-R Fully Grouted (Non-Bearing)	1
Figure 54. Roof and Parapet HI-R Fully Grouted (Bearing)	1
Figure 55. Roof and Parapet HI-R HH Partially Grouted (Non-Bearing)	1
Figure 56. Roof and Parapet HI-R HH Partially Grouted (Bearing)	1
Figure 57. Roof and Parapet HI-R HH Fully Grouted (Non-Bearing)	1
Figure 58. Roof and Parapet HI-R HH Fully Grouted (Bearing)	1
Figure 59. Roof and Parapet HI-R-H Fully Grouted (Non-Bearing)	1
Figure 60. Roof and Parapet HI-R-H Fully Grouted (Bearing)	1
Figure 61. Roof and Parapet HI-R-H HH Fully Grouted (Non-Bearing)	1
Figure 62. Roof and Parapet HI-R-H HH Fully Grouted (Bearing)	1

Roof and Parapet

Figure 51. Roof and Parapet HI-R Partially Grouted (Non-Bearing)

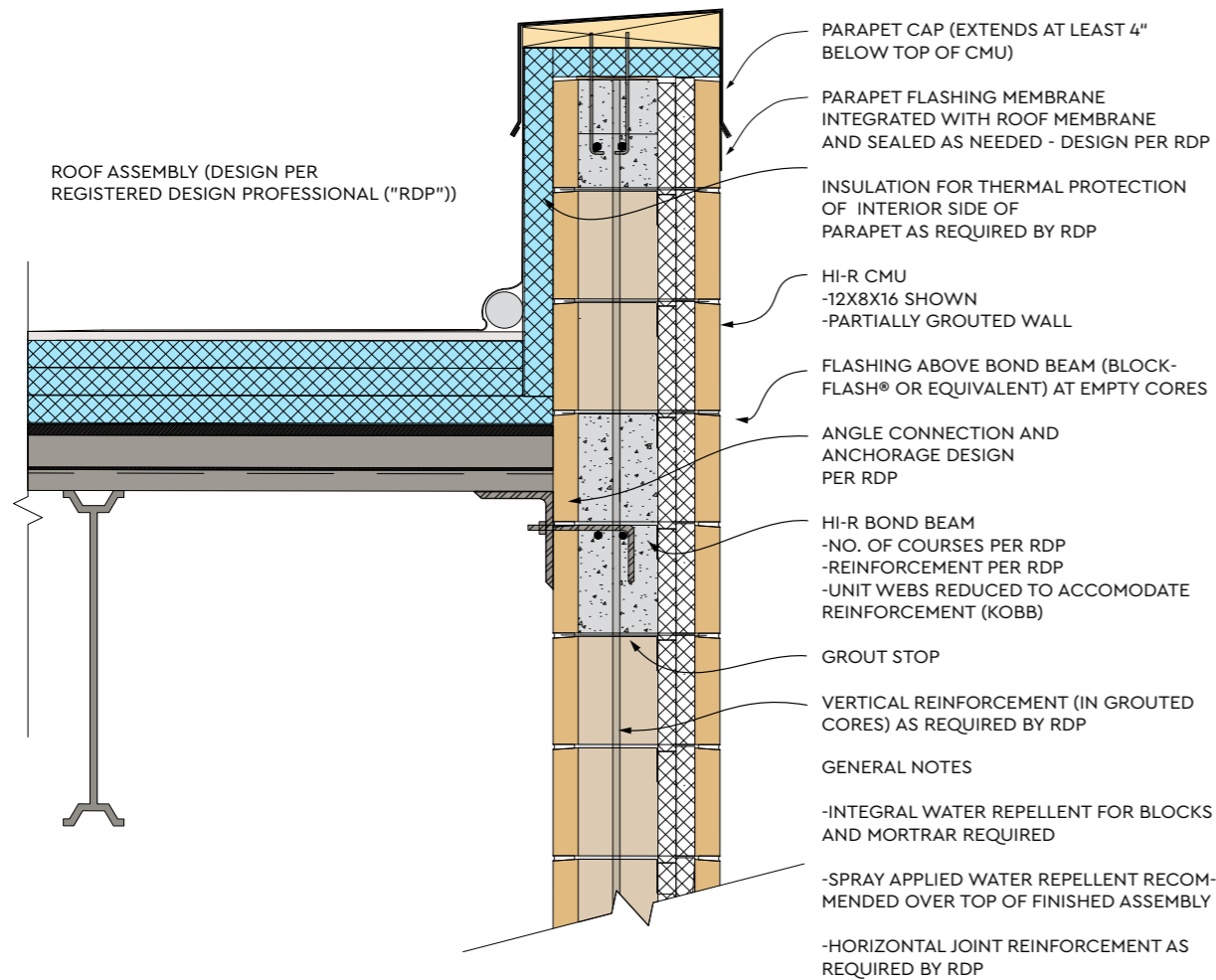

Notes:

1. This detail depicts a partially grouted wall. HI-R walls may be built either fully or partially grouted, while the HI-R-H products are fully grouted only. Fully grouting masonry walls is a cost-effective alternative to partially grouted walls. In many areas of the country where seismic design considerations are important, highly reinforced and fully grouted masonry is the preferred solution. Fully grouted walls do not require flashing at bond beam locations, and meet Code air barrier requirements.
2. For projects located in California, or other projects where compliance to vertical wall shear testing is required, alternate moisture control techniques that omit integral water repellent may be used (e.g. use IWR within mortar; use post-applied breathable penetrating sealants or drainable film forming coatings; use High Range Water Reducer in grout).
3. Request evidence in writing of adequate head joint mortar bond to IWR-containing CMU for Properties-based mortars. Request in writing evidence of sufficient composite-action bond to IWR-containing CMU of Properties-based grout.
4. Single wythe walls rely upon a belt-and-suspenders approach to moisture control. Design typically will integrate flashing and weeps, integral water repellent, post-applied moisture control means and measures, sealants, movement joints, damp-checks, crack control, thermal bridging/condensate control, as well as soil elevation offsets and below-grade damp-proofing.

Codes and Standards References

Applicable References are found in Section III.

THE DETAILS PRESENTED IN THIS MANUAL ARE STANDARD DETAILS. DESIGNERS SHOULD MAKE SITE SPECIFIC INVESTIGATIONS TO DETERMINE ACTUAL DESIGN REQUIREMENTS, WHICH MAY VARY.

CPG IS NOT RESPONSIBLE FOR USES OF THIS INFORMATION BY THIRD PARTIES, AND DOES NOT WARRANT THE FITNESS OR SUITABILITY OF THIS INFORMATION FOR ANY PURPOSE. PERSONS MAKING USE OF THIS INFORMATION DO SO AT THEIR OWN RISK.

THESE STANDARD DETAILS ARE MEANT TO ILLUSTRATE GENERAL PRINCIPLES THAT MAY BE HELPFUL, HOWEVER, FINAL DESIGN AND CONSTRUCTION SHOULD BE BASED ON ACTUAL SITE CONDITIONS AND APPLICABLE LOCAL CODE AND STANDARDS. MANY SITE OR LOCAL CONDITIONS MAY REQUIRE SPECIFIC ADDITIONAL DESIGN CONSIDERATIONS. SUCH CONDITIONS MAY INCLUDE SEISMIC ACTIVITY, LOCAL CLIMATE, WIND LOAD AND STORM CONDITIONS (INCLUDING LIKELIHOOD OF TORNADO OR HURRICANE CONDITIONS), SITE SOILS AND DRAINAGE CONSIDERATIONS, AND A VARIETY OF OTHER FACTORS THAT MAY IMPACT BUILDING PERFORMANCE ON A PARTICULAR SITE.



Figure 52. Roof and Parapet HI-R Partially Grouted (Bearing)

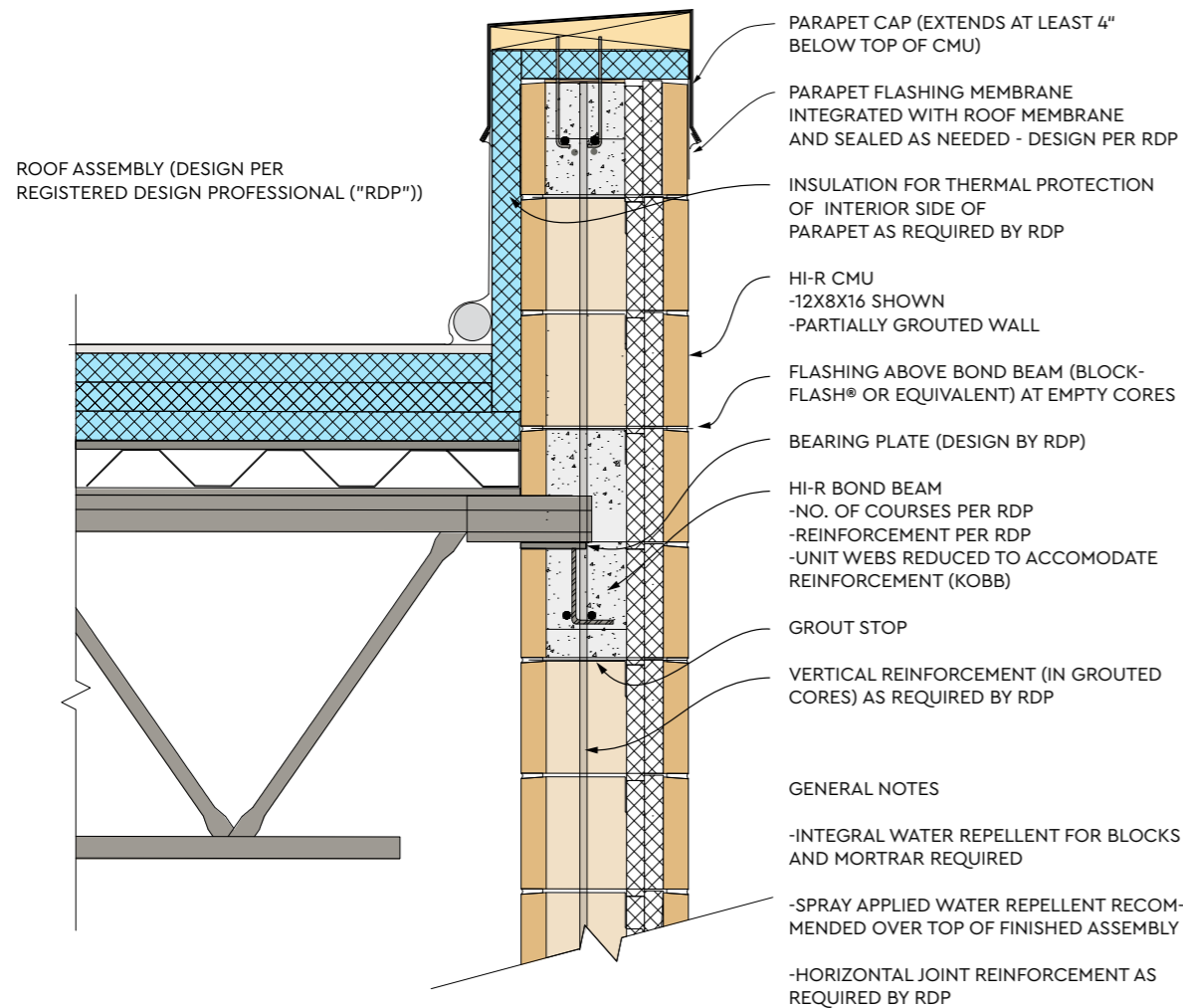

Notes:

1. This detail depicts a partially grouted wall. HI-R walls may be built either fully or partially grouted, while the HI-R-H products are fully grouted only. Fully grouting masonry walls is a cost-effective alternative to partially grouted walls. In many areas of the country where seismic design considerations are important, highly reinforced and fully grouted masonry is the preferred solution. Fully grouted walls do not require flashing at bond beam locations, and meet Code air barrier requirements.
2. For projects located in California, or other projects where compliance to vertical wall shear testing is required, alternate moisture control techniques that omit integral water repellent may be used (e.g. use IWR within mortar; use post-applied breathable penetrating sealants or drainable film forming coatings; use High Range Water Reducer in grout).
3. Request evidence in writing of adequate head joint mortar bond to IWR-containing CMU for Properties-based mortars. Request in writing evidence of sufficient composite-action bond to IWR-containing CMU of Properties-based grout.
4. Single wythe walls rely upon a belt-and-suspenders approach to moisture control. Design typically will integrate flashing and weeps, integral water repellent, post-applied moisture control means and measures, sealants, movement joints, damp-checks, crack control, thermal bridging/condensate control, as well as soil elevation offsets and below-grade damp-proofing.

Codes and Standards References

Applicable References are found in Section III.

THE DETAILS PRESENTED IN THIS MANUAL ARE STANDARD DETAILS. DESIGNERS SHOULD MAKE SITE SPECIFIC INVESTIGATIONS TO DETERMINE ACTUAL DESIGN REQUIREMENTS, WHICH MAY VARY.

CPG IS NOT RESPONSIBLE FOR USES OF THIS INFORMATION BY THIRD PARTIES, AND DOES NOT WARRANT THE FITNESS OR SUITABILITY OF THIS INFORMATION FOR ANY PURPOSE. PERSONS MAKING USE OF THIS INFORMATION DO SO AT THEIR OWN RISK.

THESE STANDARD DETAILS ARE MEANT TO ILLUSTRATE GENERAL PRINCIPLES THAT MAY BE HELPFUL, HOWEVER, FINAL DESIGN AND CONSTRUCTION SHOULD BE BASED ON ACTUAL SITE CONDITIONS AND APPLICABLE LOCAL CODE AND STANDARDS. MANY SITE OR LOCAL CONDITIONS MAY REQUIRE SPECIFIC ADDITIONAL DESIGN CONSIDERATIONS. SUCH CONDITIONS MAY INCLUDE SEISMIC ACTIVITY, LOCAL CLIMATE, WIND LOAD AND STORM CONDITIONS (INCLUDING LIKELIHOOD OF TORNADO OR HURRICANE CONDITIONS), SITE SOILS AND DRAINAGE CONSIDERATIONS, AND A VARIETY OF OTHER FACTORS THAT MAY IMPACT BUILDING PERFORMANCE ON A PARTICULAR SITE.



Figure 53. Roof and Parapet HI-R Fully Grouted (Non-Bearing)

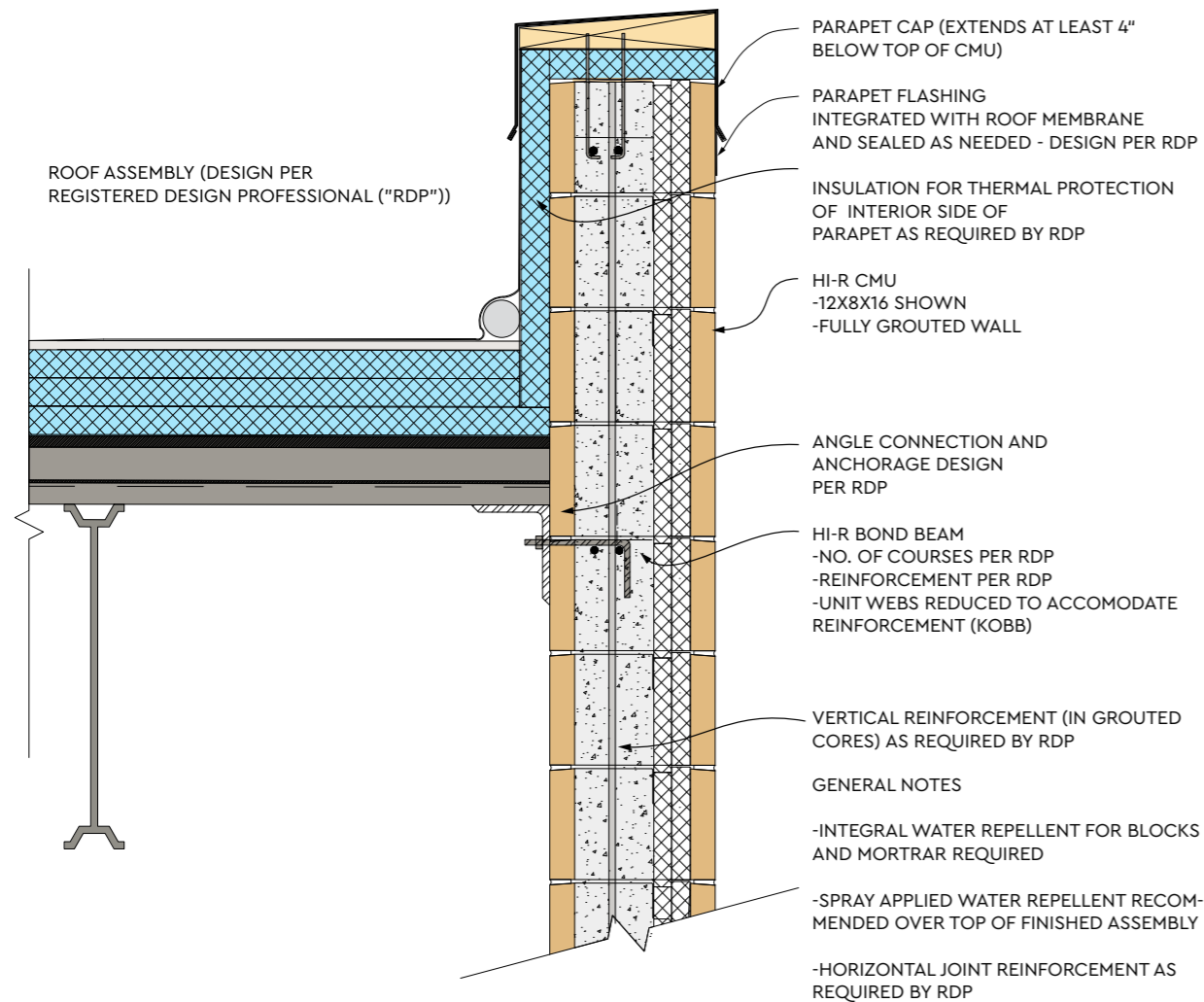

Notes:

1. This detail depicts a fully grouted wall. HI-R walls may be built either fully or partially grouted, while the HI-R-H products are fully grouted only. Fully grouting masonry walls is a cost-effective alternative to partially grouted walls. In many areas of the country where seismic design considerations are important, highly reinforced and fully grouted masonry is the preferred solution. Fully grouted walls do not require flashing at bond beam locations, and meet Code air barrier requirements.
2. For projects located in California, or other projects where compliance to vertical wall shear testing is required, alternate moisture control techniques that omit integral water repellent may be used (e.g. use IWR within mortar; use post-applied breathable penetrating sealants or drainable film forming coatings; use High Range Water Reducer in grout).
3. Request evidence in writing of adequate head joint mortar bond to IWR-containing CMU for Properties-based mortars. Request in writing evidence of sufficient composite-action bond to IWR-containing CMU of Properties-based grout.
4. Single wythe walls rely upon a belt-and-suspenders approach to moisture control. Design typically will integrate flashing and weeps, integral water repellent, post-applied moisture control means and measures, sealants, movement joints, damp-checks, crack control, thermal bridging/condensate control, as well as soil elevation offsets and below-grade damp-proofing.

Codes and Standards References

Applicable References are found in Section III.

THE DETAILS PRESENTED IN THIS MANUAL ARE STANDARD DETAILS. DESIGNERS SHOULD MAKE SITE SPECIFIC INVESTIGATIONS TO DETERMINE ACTUAL DESIGN REQUIREMENTS, WHICH MAY VARY.

CPG IS NOT RESPONSIBLE FOR USES OF THIS INFORMATION BY THIRD PARTIES, AND DOES NOT WARRANT THE FITNESS OR SUITABILITY OF THIS INFORMATION FOR ANY PURPOSE. PERSONS MAKING USE OF THIS INFORMATION DO SO AT THEIR OWN RISK.

THESE STANDARD DETAILS ARE MEANT TO ILLUSTRATE GENERAL PRINCIPLES THAT MAY BE HELPFUL, HOWEVER, FINAL DESIGN AND CONSTRUCTION SHOULD BE BASED ON ACTUAL SITE CONDITIONS AND APPLICABLE LOCAL CODE AND STANDARDS. MANY SITE OR LOCAL CONDITIONS MAY REQUIRE SPECIFIC ADDITIONAL DESIGN CONSIDERATIONS. SUCH CONDITIONS MAY INCLUDE SEISMIC ACTIVITY, LOCAL CLIMATE, WIND LOAD AND STORM CONDITIONS (INCLUDING LIKELIHOOD OF TORNADO OR HURRICANE CONDITIONS), SITE SOILS AND DRAINAGE CONSIDERATIONS, AND A VARIETY OF OTHER FACTORS THAT MAY IMPACT BUILDING PERFORMANCE ON A PARTICULAR SITE.



Figure 54. Roof and Parapet HI-R Fully Grouted (Bearing)

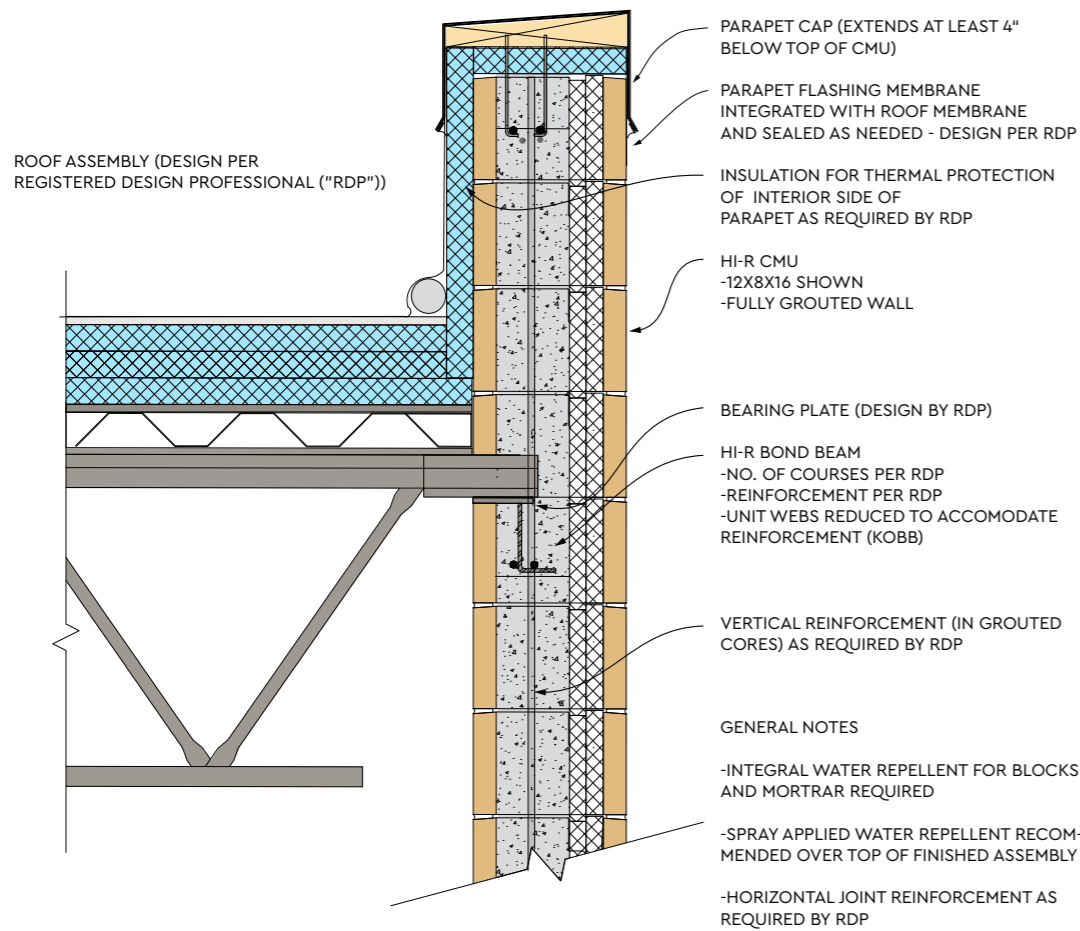

Notes:

1. This detail depicts a fully grouted wall. HI-R walls may be built either fully or partially grouted, while the HI-R-H products are fully grouted only. Fully grouting masonry walls is a cost-effective alternative to partially grouted walls. In many areas of the country where seismic design considerations are important, highly reinforced and fully grouted masonry is the preferred solution. Fully grouted walls do not require flashing at bond beam locations, and meet Code air barrier requirements.
2. For projects located in California, or other projects where compliance to vertical wall shear testing is required, alternate moisture control techniques that omit integral water repellent may be used (e.g. use IWR within mortar; use post-applied breathable penetrating sealants or drainable film forming coatings; use High Range Water Reducer in grout).
3. Request evidence in writing of adequate head joint mortar bond to IWR-containing CMU for Properties-based mortars. Request in writing evidence of sufficient composite-action bond to IWR-containing CMU of Properties-based grout.
4. Single wythe walls rely upon a belt-and-suspenders approach to moisture control. Design typically will integrate flashing and weeps, integral water repellent, post-applied moisture control means and measures, sealants, movement joints, damp-checks, crack control, thermal bridging/condensate control, as well as soil elevation offsets and below-grade damp-proofing.

Codes and Standards References

Applicable References are found in Section III.

THE DETAILS PRESENTED IN THIS MANUAL ARE STANDARD DETAILS. DESIGNERS SHOULD MAKE SITE SPECIFIC INVESTIGATIONS TO DETERMINE ACTUAL DESIGN REQUIREMENTS, WHICH MAY VARY.

CPG IS NOT RESPONSIBLE FOR USES OF THIS INFORMATION BY THIRD PARTIES, AND DOES NOT WARRANT THE FITNESS OR SUITABILITY OF THIS INFORMATION FOR ANY PURPOSE. PERSONS MAKING USE OF THIS INFORMATION DO SO AT THEIR OWN RISK.

THESE STANDARD DETAILS ARE MEANT TO ILLUSTRATE GENERAL PRINCIPLES THAT MAY BE HELPFUL, HOWEVER, FINAL DESIGN AND CONSTRUCTION SHOULD BE BASED ON ACTUAL SITE CONDITIONS AND APPLICABLE LOCAL CODE AND STANDARDS. MANY SITE OR LOCAL CONDITIONS MAY REQUIRE SPECIFIC ADDITIONAL DESIGN CONSIDERATIONS. SUCH CONDITIONS MAY INCLUDE SEISMIC ACTIVITY, LOCAL CLIMATE, WIND LOAD AND STORM CONDITIONS (INCLUDING LIKELIHOOD OF TORNADO OR HURRICANE CONDITIONS), SITE SOILS AND DRAINAGE CONSIDERATIONS, AND A VARIETY OF OTHER FACTORS THAT MAY IMPACT BUILDING PERFORMANCE ON A PARTICULAR SITE.



Figure 55. Roof and Parapet HI-R Half High Partially Grouted (Non-Bearing)

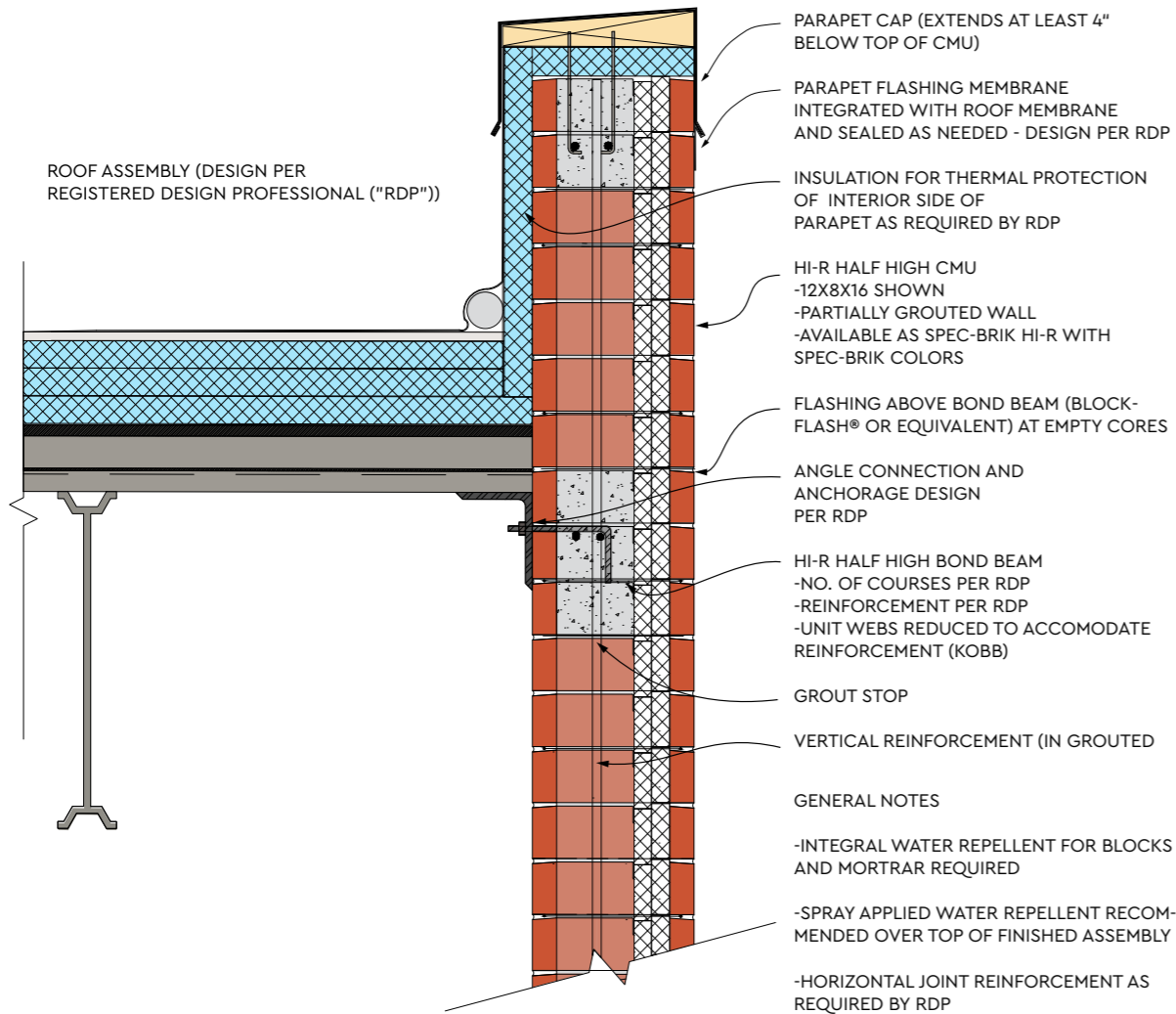

Notes:

1. This detail depicts a partially grouted wall. HI-R walls may be built either fully or partially grouted, while the HI-R-H products are fully grouted only. Fully grouting masonry walls is a cost-effective alternative to partially grouted walls. In many areas of the country where seismic design considerations are important, highly reinforced and fully grouted masonry is the preferred solution. Fully grouted walls do not require flashing at bond beam locations, and meet Code air barrier requirements.
2. For projects located in California, or other projects where compliance to vertical wall shear testing is required, alternate moisture control techniques that omit integral water repellent may be used (e.g. use IWR within mortar; use post-applied breathable penetrating sealants or drainable film forming coatings; use High Range Water Reducer in grout).
3. Request evidence in writing of adequate head joint mortar bond to IWR-containing CMU for Properties-based mortars. Request in writing evidence of sufficient composite-action bond to IWR-containing CMU of Properties-based grout.
4. Single wythe walls rely upon a belt-and-suspenders approach to moisture control. Design typically will integrate flashing and weeps, integral water repellent, post-applied moisture control means and measures, sealants, movement joints, damp-checks, crack control, thermal bridging/condensate control, as well as soil elevation offsets and below-grade damp-proofing.

Codes and Standards References

Applicable References are found in Section III.

THE DETAILS PRESENTED IN THIS MANUAL ARE STANDARD DETAILS. DESIGNERS SHOULD MAKE SITE SPECIFIC INVESTIGATIONS TO DETERMINE ACTUAL DESIGN REQUIREMENTS, WHICH MAY VARY.

CPG IS NOT RESPONSIBLE FOR USES OF THIS INFORMATION BY THIRD PARTIES, AND DOES NOT WARRANT THE FITNESS OR SUITABILITY OF THIS INFORMATION FOR ANY PURPOSE. PERSONS MAKING USE OF THIS INFORMATION DO SO AT THEIR OWN RISK.

THESE STANDARD DETAILS ARE MEANT TO ILLUSTRATE GENERAL PRINCIPLES THAT MAY BE HELPFUL, HOWEVER, FINAL DESIGN AND CONSTRUCTION SHOULD BE BASED ON ACTUAL SITE CONDITIONS AND APPLICABLE LOCAL CODE AND STANDARDS. MANY SITE OR LOCAL CONDITIONS MAY REQUIRE SPECIFIC ADDITIONAL DESIGN CONSIDERATIONS. SUCH CONDITIONS MAY INCLUDE SEISMIC ACTIVITY, LOCAL CLIMATE, WIND LOAD AND STORM CONDITIONS (INCLUDING LIKELIHOOD OF TORNADO OR HURRICANE CONDITIONS), SITE SOILS AND DRAINAGE CONSIDERATIONS, AND A VARIETY OF OTHER FACTORS THAT MAY IMPACT BUILDING PERFORMANCE ON A PARTICULAR SITE.



Figure 56. Roof and Parapet HI-R HH Partially Grouted (Bearing)

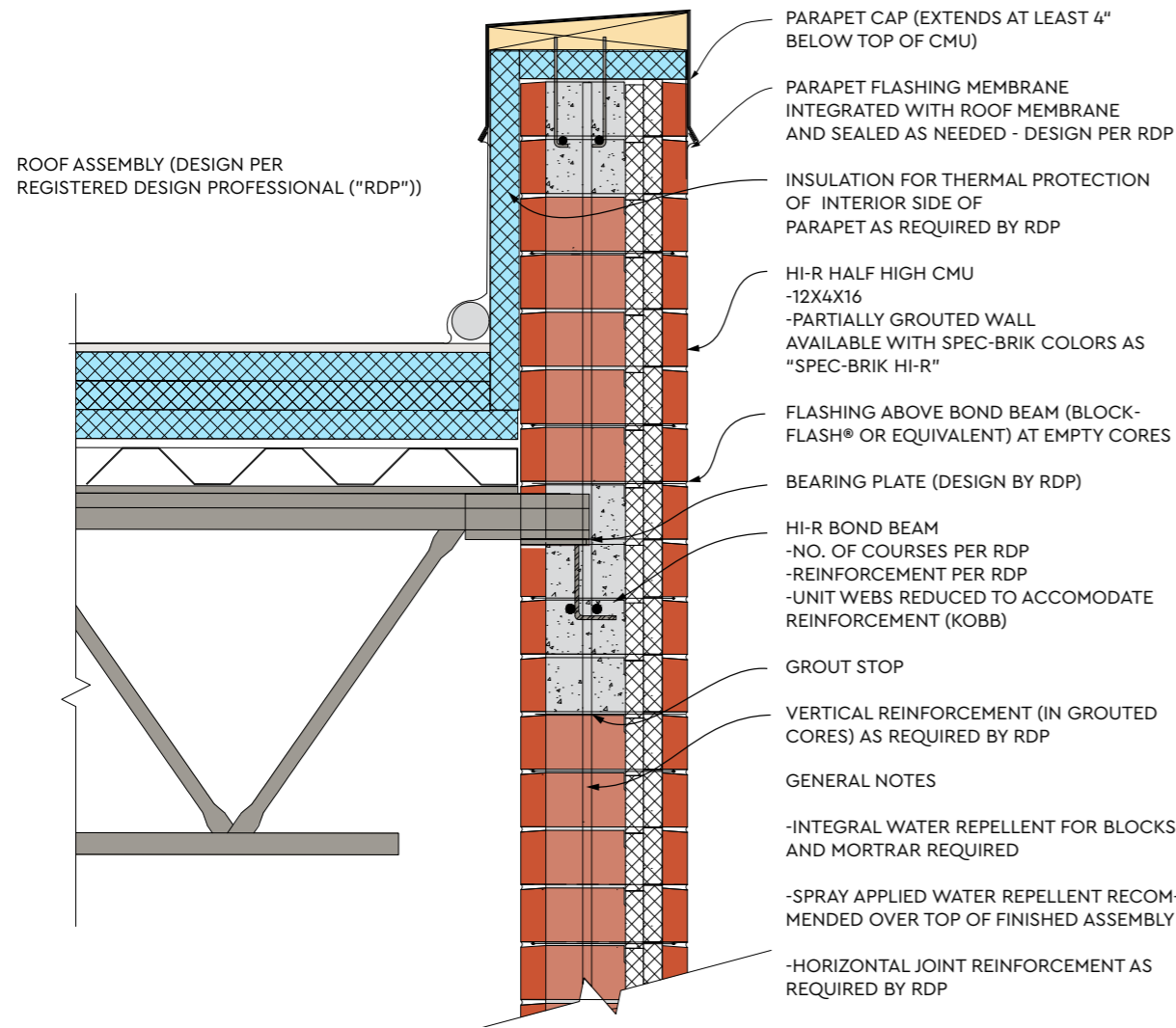

Notes:

1. This detail depicts a partially grouted wall. HI-R walls may be built either fully or partially grouted, while the HI-R-H products are fully grouted only. Fully grouting masonry walls is a cost-effective alternative to partially grouted walls. In many areas of the country where seismic design considerations are important, highly reinforced and fully grouted masonry is the preferred solution. Fully grouted walls do not require flashing at bond beam locations, and meet Code air barrier requirements.
2. For projects located in California, or other projects where compliance to vertical wall shear testing is required, alternate moisture control techniques that omit integral water repellent may be used (e.g. use IWR within mortar; use post-applied breathable penetrating sealants or drainable film forming coatings; use High Range Water Reducer in grout).
3. Request evidence in writing of adequate head joint mortar bond to IWR-containing CMU for Properties-based mortars. Request in writing evidence of sufficient composite-action bond to IWR-containing CMU of Properties-based grout.
4. Single wythe walls rely upon a belt-and-suspenders approach to moisture control. Design typically will integrate flashing and weeps, integral water repellent, post-applied moisture control means and measures, sealants, movement joints, damp-checks, crack control, thermal bridging/condensate control, as well as soil elevation offsets and below-grade damp-proofing.

Codes and Standards References

Applicable References are found in Section III.

THE DETAILS PRESENTED IN THIS MANUAL ARE STANDARD DETAILS. DESIGNERS SHOULD MAKE SITE SPECIFIC INVESTIGATIONS TO DETERMINE ACTUAL DESIGN REQUIREMENTS, WHICH MAY VARY.

CPG IS NOT RESPONSIBLE FOR USES OF THIS INFORMATION BY THIRD PARTIES, AND DOES NOT WARRANT THE FITNESS OR SUITABILITY OF THIS INFORMATION FOR ANY PURPOSE. PERSONS MAKING USE OF THIS INFORMATION DO SO AT THEIR OWN RISK.

THESE STANDARD DETAILS ARE MEANT TO ILLUSTRATE GENERAL PRINCIPLES THAT MAY BE HELPFUL, HOWEVER, FINAL DESIGN AND CONSTRUCTION SHOULD BE BASED ON ACTUAL SITE CONDITIONS AND APPLICABLE LOCAL CODE AND STANDARDS. MANY SITE OR LOCAL CONDITIONS MAY REQUIRE SPECIFIC ADDITIONAL DESIGN CONSIDERATIONS. SUCH CONDITIONS MAY INCLUDE SEISMIC ACTIVITY, LOCAL CLIMATE, WIND LOAD AND STORM CONDITIONS (INCLUDING LIKELIHOOD OF TORNADO OR HURRICANE CONDITIONS), SITE SOILS AND DRAINAGE CONSIDERATIONS, AND A VARIETY OF OTHER FACTORS THAT MAY IMPACT BUILDING PERFORMANCE ON A PARTICULAR SITE.



Figure 57. Roof and Parapet HI-R Half High Fully Grouted (Non-Bearing)

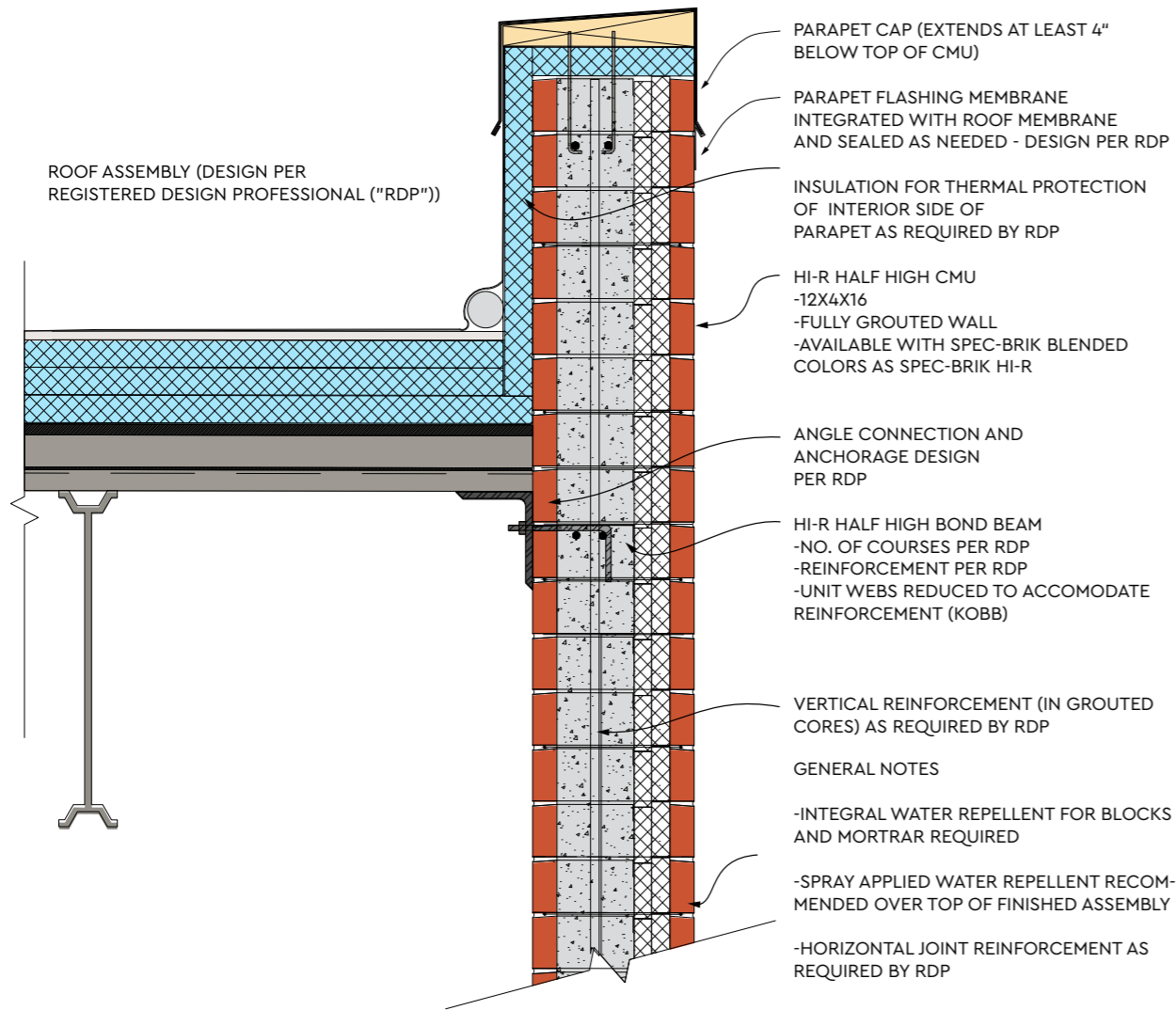

Notes:

1. This detail depicts a fully grouted wall. HI-R walls may be built either fully or partially grouted, while the HI-R-H products are fully grouted only. Fully grouting masonry walls is a cost-effective alternative to partially grouted walls. In many areas of the country where seismic design considerations are important, highly reinforced and fully grouted masonry is the preferred solution. Fully grouted walls do not require flashing at bond beam locations, and meet Code air barrier requirements.
2. For projects located in California, or other projects where compliance to vertical wall shear testing is required, alternate moisture control techniques that omit integral water repellent may be used (e.g. use IWR within mortar; use post-applied breathable penetrating sealants or drainable film forming coatings; use High Range Water Reducer in grout).
3. Request evidence in writing of adequate head joint mortar bond to IWR-containing CMU for Properties-based mortars. Request in writing evidence of sufficient composite-action bond to IWR-containing CMU of Properties-based grout.
4. Single wythe walls rely upon a belt-and-suspenders approach to moisture control. Design typically will integrate flashing and weeps, integral water repellent, post-applied moisture control means and measures, sealants, movement joints, damp-checks, crack control, thermal bridging/condensate control, as well as soil elevation offsets and below-grade damp-proofing.

Codes and Standards References

Applicable References are found in Section III.

THE DETAILS PRESENTED IN THIS MANUAL ARE STANDARD DETAILS. DESIGNERS SHOULD MAKE SITE SPECIFIC INVESTIGATIONS TO DETERMINE ACTUAL DESIGN REQUIREMENTS, WHICH MAY VARY.

CPG IS NOT RESPONSIBLE FOR USES OF THIS INFORMATION BY THIRD PARTIES, AND DOES NOT WARRANT THE FITNESS OR SUITABILITY OF THIS INFORMATION FOR ANY PURPOSE. PERSONS MAKING USE OF THIS INFORMATION DO SO AT THEIR OWN RISK.

THESE STANDARD DETAILS ARE MEANT TO ILLUSTRATE GENERAL PRINCIPLES THAT MAY BE HELPFUL, HOWEVER, FINAL DESIGN AND CONSTRUCTION SHOULD BE BASED ON ACTUAL SITE CONDITIONS AND APPLICABLE LOCAL CODE AND STANDARDS. MANY SITE OR LOCAL CONDITIONS MAY REQUIRE SPECIFIC ADDITIONAL DESIGN CONSIDERATIONS. SUCH CONDITIONS MAY INCLUDE SEISMIC ACTIVITY, LOCAL CLIMATE, WIND LOAD AND STORM CONDITIONS (INCLUDING LIKELIHOOD OF TORNADO OR HURRICANE CONDITIONS), SITE SOILS AND DRAINAGE CONSIDERATIONS, AND A VARIETY OF OTHER FACTORS THAT MAY IMPACT BUILDING PERFORMANCE ON A PARTICULAR SITE.



Figure 58. Roof and Parapet HI-R Half High Fully Grouted (Bearing)

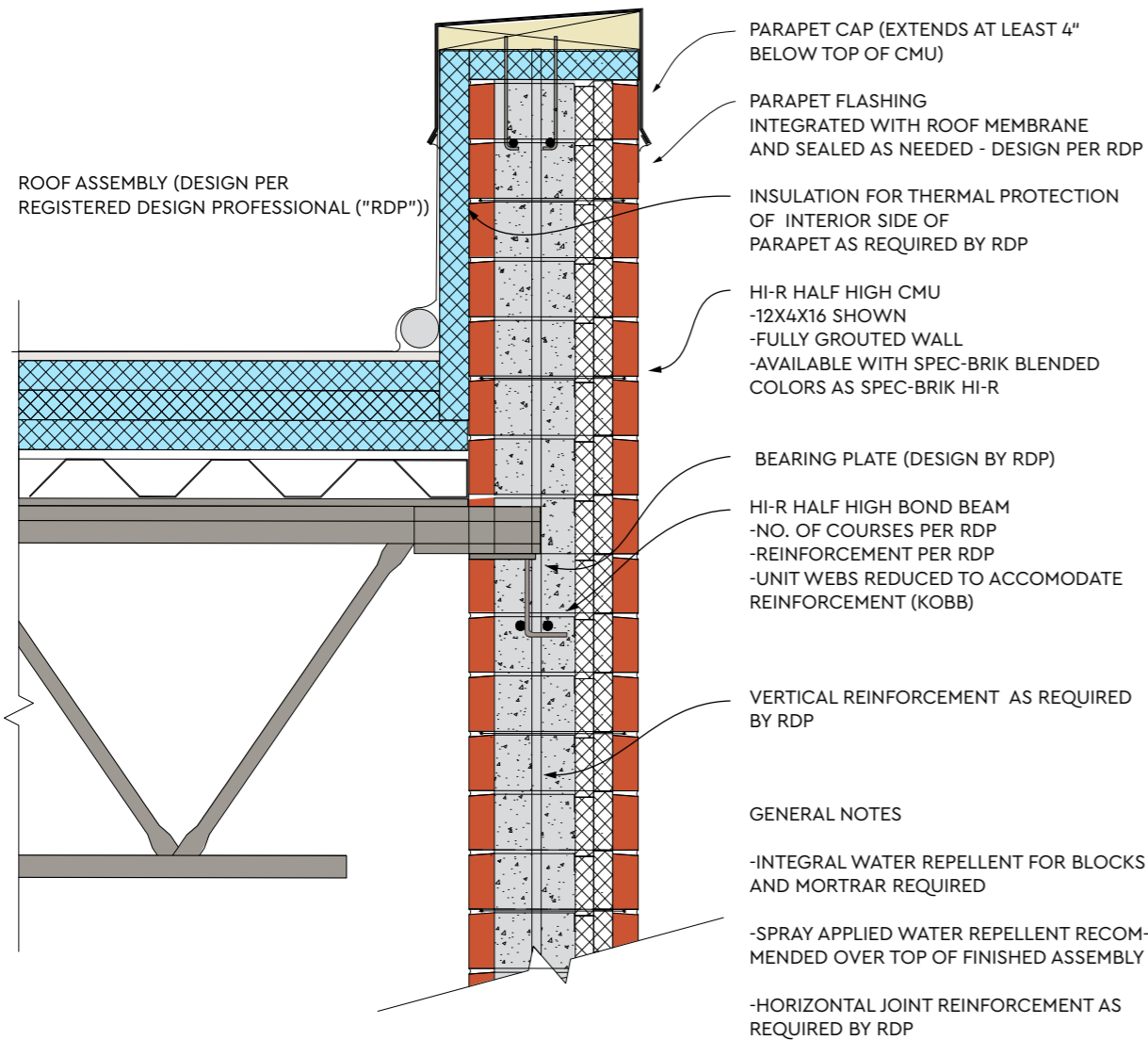

Notes:

1. This detail depicts a fully grouted wall. HI-R walls may be built either fully or partially grouted, while the HI-R-H products are fully grouted only. Fully grouting masonry walls is a cost-effective alternative to partially grouted walls. In many areas of the country where seismic design considerations are important, highly reinforced and fully grouted masonry is the preferred solution. Fully grouted walls do not require flashing at bond beam locations, and meet Code air barrier requirements.
2. For projects located in California, or other projects where compliance to vertical wall shear testing is required, alternate moisture control techniques that omit integral water repellent may be used (e.g. use IWR within mortar; use post-applied breathable penetrating sealants or drainable film forming coatings; use High Range Water Reducer in grout).
3. Request evidence in writing of adequate head joint mortar bond to IWR-containing CMU for Properties-based mortars. Request in writing evidence of sufficient composite-action bond to IWR-containing CMU of Properties-based grout.
4. Single wythe walls rely upon a belt-and-suspenders approach to moisture control. Design typically will integrate flashing and weeps, integral water repellent, post-applied moisture control means and measures, sealants, movement joints, damp-checks, crack control, thermal bridging/condensate control, as well as soil elevation offsets and below-grade damp-proofing.

Codes and Standards References

Applicable References are found in Section III.

THE DETAILS PRESENTED IN THIS MANUAL ARE STANDARD DETAILS. DESIGNERS SHOULD MAKE SITE SPECIFIC INVESTIGATIONS TO DETERMINE ACTUAL DESIGN REQUIREMENTS, WHICH MAY VARY.

CPG IS NOT RESPONSIBLE FOR USES OF THIS INFORMATION BY THIRD PARTIES, AND DOES NOT WARRANT THE FITNESS OR SUITABILITY OF THIS INFORMATION FOR ANY PURPOSE. PERSONS MAKING USE OF THIS INFORMATION DO SO AT THEIR OWN RISK.

THESE STANDARD DETAILS ARE MEANT TO ILLUSTRATE GENERAL PRINCIPLES THAT MAY BE HELPFUL, HOWEVER, FINAL DESIGN AND CONSTRUCTION SHOULD BE BASED ON ACTUAL SITE CONDITIONS AND APPLICABLE LOCAL CODE AND STANDARDS. MANY SITE OR LOCAL CONDITIONS MAY REQUIRE SPECIFIC ADDITIONAL DESIGN CONSIDERATIONS. SUCH CONDITIONS MAY INCLUDE SEISMIC ACTIVITY, LOCAL CLIMATE, WIND LOAD AND STORM CONDITIONS (INCLUDING LIKELIHOOD OF TORNADO OR HURRICANE CONDITIONS), SITE SOILS AND DRAINAGE CONSIDERATIONS, AND A VARIETY OF OTHER FACTORS THAT MAY IMPACT BUILDING PERFORMANCE ON A PARTICULAR SITE.



Figure 59. Roof and Parapet HI-R-H Fully Grouted (Non-Bearing)

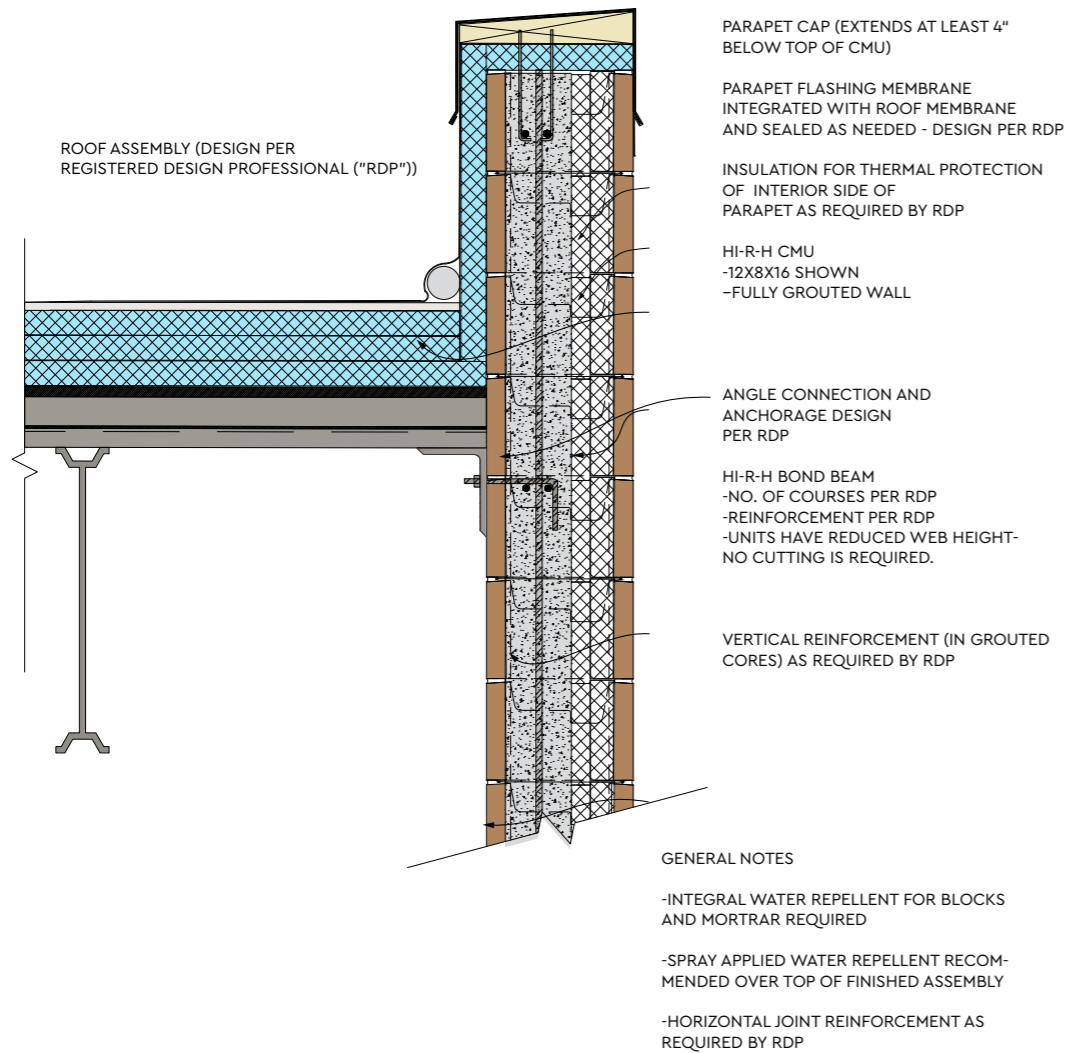

Notes:

1. This detail depicts a fully grouted wall. HI-R walls may be built either fully or partially grouted, while the HI-R-H products are fully grouted only. Fully grouting masonry walls is a cost-effective alternative to partially grouted walls. In many areas of the country where seismic design considerations are important, highly reinforced and fully grouted masonry is the preferred solution. Fully grouted walls do not require flashing at bond beam locations, and meet Code air barrier requirements.
2. For projects located in California, or other projects where compliance to vertical wall shear testing is required, alternate moisture control techniques that omit integral water repellent may be used (e.g. use IWR within mortar; use post-applied breathable penetrating sealants or drainable film forming coatings; use High Range Water Reducer in grout).
3. Request evidence in writing of adequate head joint mortar bond to IWR-containing CMU for Properties-based mortars. Request in writing evidence of sufficient composite-action bond to IWR-containing CMU of Properties-based grout.
4. Single wythe walls rely upon a belt-and-suspenders approach to moisture control. Design typically will integrate flashing and weeps, integral water repellent, post-applied moisture control means and measures, sealants, movement joints, damp-checks, crack control, thermal bridging/condensate control, as well as soil elevation offsets and below-grade damp-proofing.

Codes and Standards References

Applicable References are found in Section III.

THE DETAILS PRESENTED IN THIS MANUAL ARE STANDARD DETAILS. DESIGNERS SHOULD MAKE SITE SPECIFIC INVESTIGATIONS TO DETERMINE ACTUAL DESIGN REQUIREMENTS, WHICH MAY VARY.

CPG IS NOT RESPONSIBLE FOR USES OF THIS INFORMATION BY THIRD PARTIES, AND DOES NOT WARRANT THE FITNESS OR SUITABILITY OF THIS INFORMATION FOR ANY PURPOSE. PERSONS MAKING USE OF THIS INFORMATION DO SO AT THEIR OWN RISK.

THESE STANDARD DETAILS ARE MEANT TO ILLUSTRATE GENERAL PRINCIPLES THAT MAY BE HELPFUL, HOWEVER, FINAL DESIGN AND CONSTRUCTION SHOULD BE BASED ON ACTUAL SITE CONDITIONS AND APPLICABLE LOCAL CODE AND STANDARDS. MANY SITE OR LOCAL CONDITIONS MAY REQUIRE SPECIFIC ADDITIONAL DESIGN CONSIDERATIONS. SUCH CONDITIONS MAY INCLUDE SEISMIC ACTIVITY, LOCAL CLIMATE, WIND LOAD AND STORM CONDITIONS (INCLUDING LIKELIHOOD OF TORNADO OR HURRICANE CONDITIONS), SITE SOILS AND DRAINAGE CONSIDERATIONS, AND A VARIETY OF OTHER FACTORS THAT MAY IMPACT BUILDING PERFORMANCE ON A PARTICULAR SITE.



Figure 60. Roof and Parapet HI-R-H Fully Grouted (Bearing)

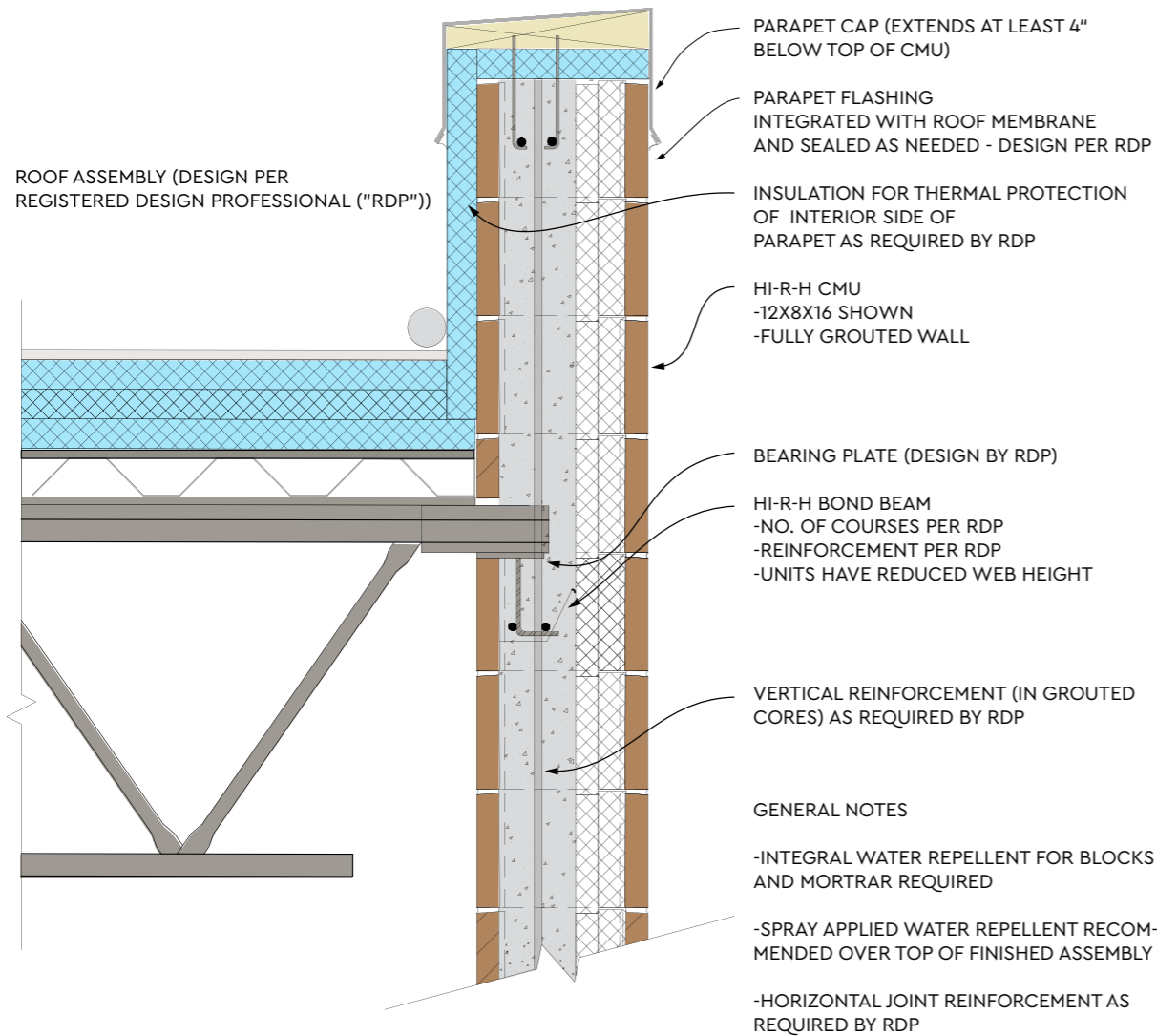

Notes:

1. This detail depicts a fully grouted wall. HI-R walls may be built either fully or partially grouted, while the HI-R-H products are fully grouted only. Fully grouting masonry walls is a cost-effective alternative to partially grouted walls. In many areas of the country where seismic design considerations are important, highly reinforced and fully grouted masonry is the preferred solution. Fully grouted walls do not require flashing at bond beam locations, and meet Code air barrier requirements.
2. For projects located in California, or other projects where compliance to vertical wall shear testing is required, alternate moisture control techniques that omit integral water repellent may be used (e.g. use IWR within mortar; use post-applied breathable penetrating sealants or drainable film forming coatings; use High Range Water Reducer in grout).
3. Request evidence in writing of adequate head joint mortar bond to IWR-containing CMU for Properties-based mortars. Request in writing evidence of sufficient composite-action bond to IWR-containing CMU of Properties-based grout.
4. Single wythe walls rely upon a belt-and-suspenders approach to moisture control. Design typically will integrate flashing and weeps, integral water repellent, post-applied moisture control means and measures, sealants, movement joints, damp-checks, crack control, thermal bridging/condensate control, as well as soil elevation offsets and below-grade damp-proofing.

Codes and Standards References

Applicable References are found in Section III.

THE DETAILS PRESENTED IN THIS MANUAL ARE STANDARD DETAILS. DESIGNERS SHOULD MAKE SITE SPECIFIC INVESTIGATIONS TO DETERMINE ACTUAL DESIGN REQUIREMENTS, WHICH MAY VARY.

CPG IS NOT RESPONSIBLE FOR USES OF THIS INFORMATION BY THIRD PARTIES, AND DOES NOT WARRANT THE FITNESS OR SUITABILITY OF THIS INFORMATION FOR ANY PURPOSE. PERSONS MAKING USE OF THIS INFORMATION DO SO AT THEIR OWN RISK.

THESE STANDARD DETAILS ARE MEANT TO ILLUSTRATE GENERAL PRINCIPLES THAT MAY BE HELPFUL, HOWEVER, FINAL DESIGN AND CONSTRUCTION SHOULD BE BASED ON ACTUAL SITE CONDITIONS AND APPLICABLE LOCAL CODE AND STANDARDS. MANY SITE OR LOCAL CONDITIONS MAY REQUIRE SPECIFIC ADDITIONAL DESIGN CONSIDERATIONS. SUCH CONDITIONS MAY INCLUDE SEISMIC ACTIVITY, LOCAL CLIMATE, WIND LOAD AND STORM CONDITIONS (INCLUDING LIKELIHOOD OF TORNADO OR HURRICANE CONDITIONS), SITE SOILS AND DRAINAGE CONSIDERATIONS, AND A VARIETY OF OTHER FACTORS THAT MAY IMPACT BUILDING PERFORMANCE ON A PARTICULAR SITE.



Figure 61. Roof and Parapet HI-R-H Half High Fully Grouted (Non-Bearing)

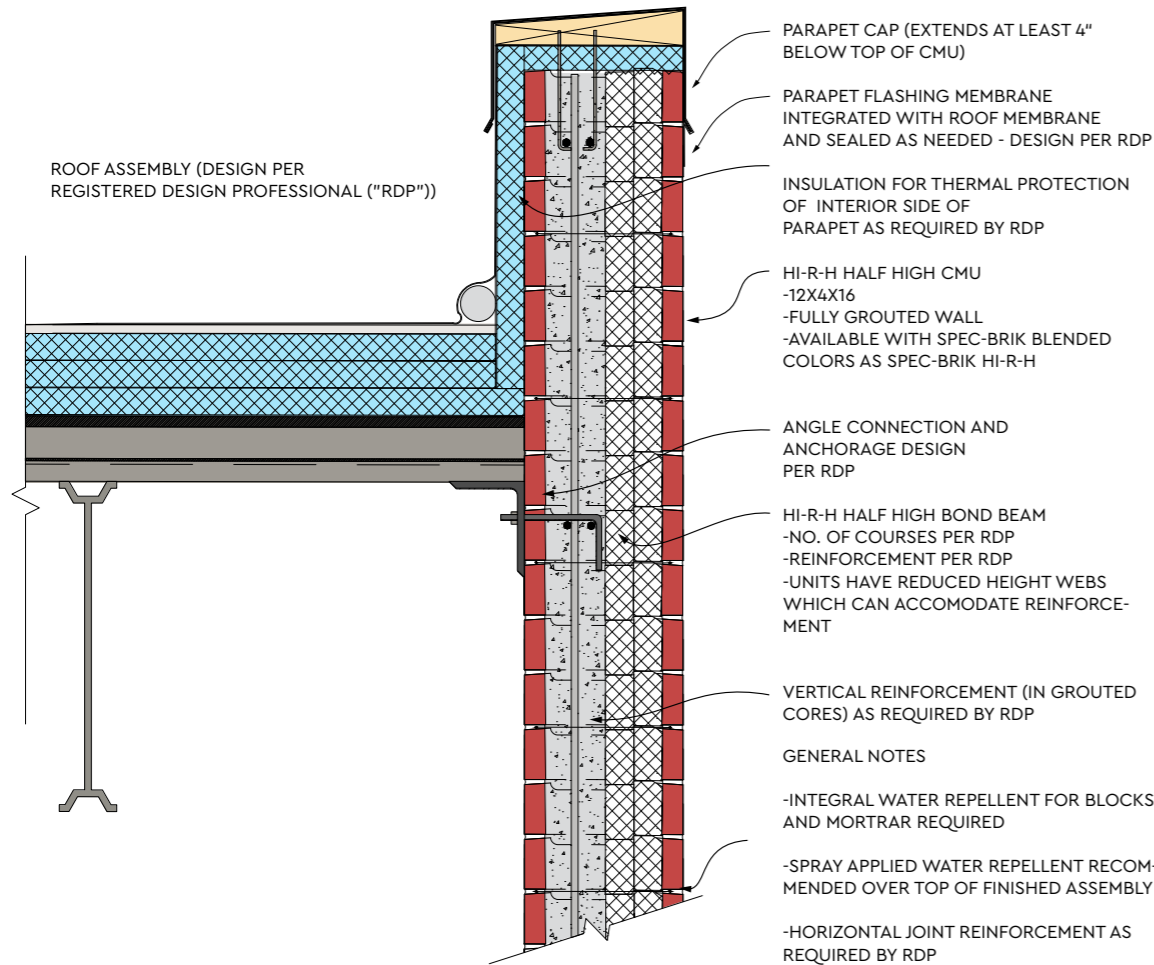

Notes:

1. This detail depicts a fully grouted wall. HI-R walls may be built either fully or partially grouted, while the HI-R-H products are fully grouted only. Fully grouting masonry walls is a cost-effective alternative to partially grouted walls. In many areas of the country where seismic design considerations are important, highly reinforced and fully grouted masonry is the preferred solution. Fully grouted walls do not require flashing at bond beam locations, and meet Code air barrier requirements.
2. For projects located in California, or other projects where compliance to vertical wall shear testing is required, alternate moisture control techniques that omit integral water repellent may be used (e.g. use IWR within mortar; use post-applied breathable penetrating sealants or drainable film forming coatings; use High Range Water Reducer in grout).
3. Request evidence in writing of adequate head joint mortar bond to IWR-containing CMU for Properties-based mortars. Request in writing evidence of sufficient composite-action bond to IWR-containing CMU of Properties-based grout.
4. Single wythe walls rely upon a belt-and-suspenders approach to moisture control. Design typically will integrate flashing and weeps, integral water repellent, post-applied moisture control means and measures, sealants, movement joints, damp-checks, crack control, thermal bridging/condensate control, as well as soil elevation offsets and below-grade damp-proofing.

Codes and Standards References

Applicable References are found in Section III.

THE DETAILS PRESENTED IN THIS MANUAL ARE STANDARD DETAILS. DESIGNERS SHOULD MAKE SITE SPECIFIC INVESTIGATIONS TO DETERMINE ACTUAL DESIGN REQUIREMENTS, WHICH MAY VARY.

CPG IS NOT RESPONSIBLE FOR USES OF THIS INFORMATION BY THIRD PARTIES, AND DOES NOT WARRANT THE FITNESS OR SUITABILITY OF THIS INFORMATION FOR ANY PURPOSE. PERSONS MAKING USE OF THIS INFORMATION DO SO AT THEIR OWN RISK.

THESE STANDARD DETAILS ARE MEANT TO ILLUSTRATE GENERAL PRINCIPLES THAT MAY BE HELPFUL, HOWEVER, FINAL DESIGN AND CONSTRUCTION SHOULD BE BASED ON ACTUAL SITE CONDITIONS AND APPLICABLE LOCAL CODE AND STANDARDS. MANY SITE OR LOCAL CONDITIONS MAY REQUIRE SPECIFIC ADDITIONAL DESIGN CONSIDERATIONS. SUCH CONDITIONS MAY INCLUDE SEISMIC ACTIVITY, LOCAL CLIMATE, WIND LOAD AND STORM CONDITIONS (INCLUDING LIKELIHOOD OF TORNADO OR HURRICANE CONDITIONS), SITE SOILS AND DRAINAGE CONSIDERATIONS, AND A VARIETY OF OTHER FACTORS THAT MAY IMPACT BUILDING PERFORMANCE ON A PARTICULAR SITE.



Figure 62. Roof and Parapet HI-R-H HH Fully Grouted (Bearing)

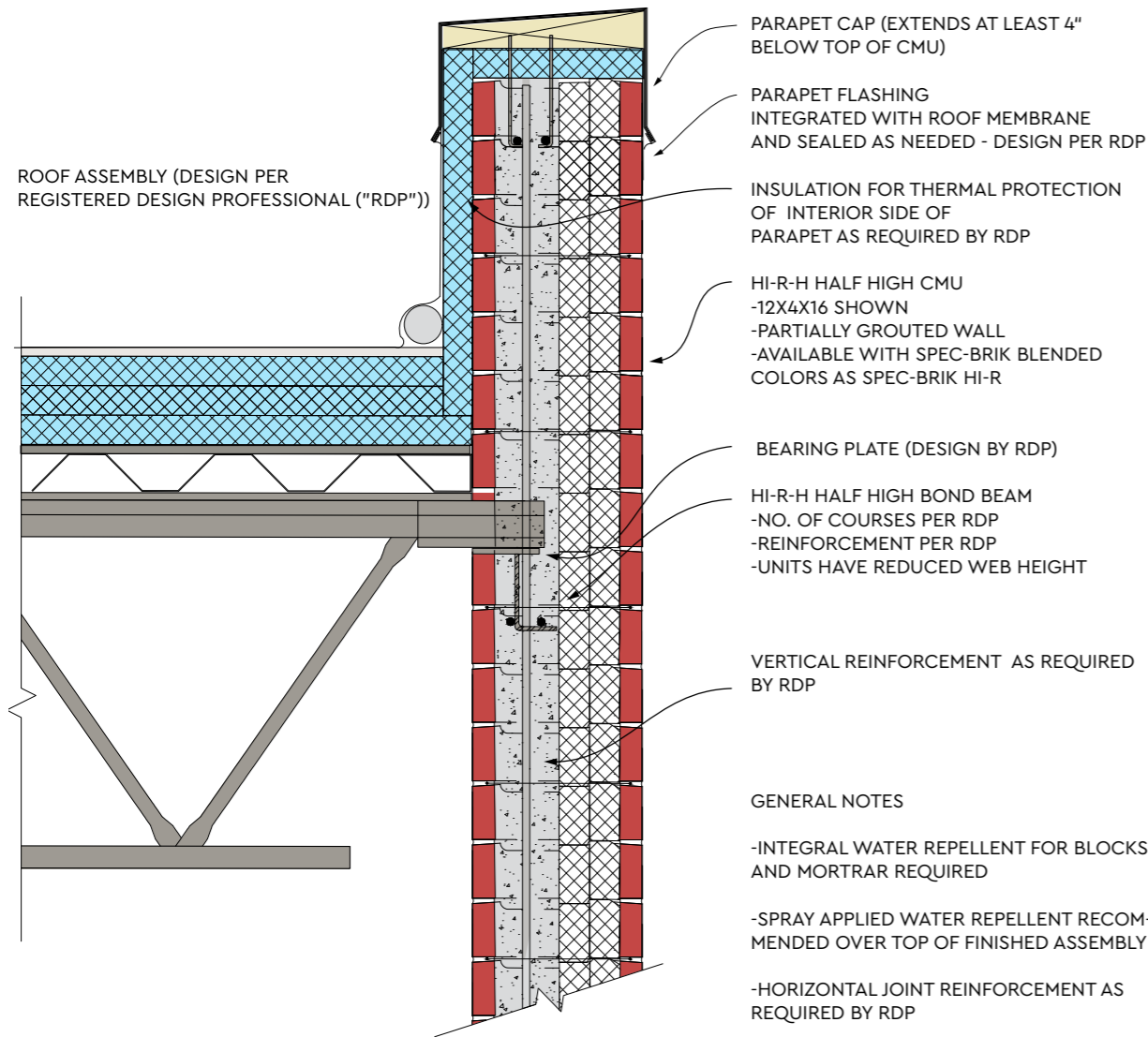

Notes:

1. This detail depicts a fully grouted wall. HI-R walls may be built either fully or partially grouted, while the HI-R-H products are fully grouted only. Fully grouting masonry walls is a cost-effective alternative to partially grouted walls. In many areas of the country where seismic design considerations are important, highly reinforced and fully grouted masonry is the preferred solution. Fully grouted walls do not require flashing at bond beam locations, and meet Code air barrier requirements.
2. For projects located in California, or other projects where compliance to vertical wall shear testing is required, alternate moisture control techniques that omit integral water repellent may be used (e.g. use IWR within mortar; use post-applied breathable penetrating sealants or drainable film forming coatings; use High Range Water Reducer in grout).
3. Request evidence in writing of adequate head joint mortar bond to IWR-containing CMU for Properties-based mortars. Request in writing evidence of sufficient composite-action bond to IWR-containing CMU of Properties-based grout.
4. Single wythe walls rely upon a belt-and-suspenders approach to moisture control. Design typically will integrate flashing and weeps, integral water repellent, post-applied moisture control means and measures, sealants, movement joints, damp-checks, crack control, thermal bridging/condensate control, as well as soil elevation offsets and below-grade damp-proofing.

Codes and Standards References

Applicable References are found in Section III.

THE DETAILS PRESENTED IN THIS MANUAL ARE STANDARD DETAILS. DESIGNERS SHOULD MAKE SITE SPECIFIC INVESTIGATIONS TO DETERMINE ACTUAL DESIGN REQUIREMENTS, WHICH MAY VARY.

CPG IS NOT RESPONSIBLE FOR USES OF THIS INFORMATION BY THIRD PARTIES, AND DOES NOT WARRANT THE FITNESS OR SUITABILITY OF THIS INFORMATION FOR ANY PURPOSE. PERSONS MAKING USE OF THIS INFORMATION DO SO AT THEIR OWN RISK.

THESE STANDARD DETAILS ARE MEANT TO ILLUSTRATE GENERAL PRINCIPLES THAT MAY BE HELPFUL, HOWEVER, FINAL DESIGN AND CONSTRUCTION SHOULD BE BASED ON ACTUAL SITE CONDITIONS AND APPLICABLE LOCAL CODE AND STANDARDS. MANY SITE OR LOCAL CONDITIONS MAY REQUIRE SPECIFIC ADDITIONAL DESIGN CONSIDERATIONS. SUCH CONDITIONS MAY INCLUDE SEISMIC ACTIVITY, LOCAL CLIMATE, WIND LOAD AND STORM CONDITIONS (INCLUDING LIKELIHOOD OF TORNADO OR HURRICANE CONDITIONS), SITE SOILS AND DRAINAGE CONSIDERATIONS, AND A VARIETY OF OTHER FACTORS THAT MAY IMPACT BUILDING PERFORMANCE ON A PARTICULAR SITE.



Section III Codes and Standards References

A small thumbnail of a table of contents is located in the bottom right corner. It is titled 'Table of Contents' and lists various sections with corresponding page numbers. The text is too small to read clearly, but it appears to be a standard table of contents for a document.

Applicable Code References for Single Wythe Walls

These references are intended to be a guide to the portions of the Model Codes that apply or relate to the construction of Single Wythe Walls. This set of references is only a starting point, and you should be sure to check the underlying Code itself and be sure to check the local Code that the Authority Having Jurisdiction has authorized for the location applicable to your project.

International Building Code ("IBC") (2006 and 2009); INTERNATIONAL CODE COUNCIL, INC., 4051 West Flossmoor Road, Country Club Hills, IL 60478, including but not limited to:

CHAPTER 1 SCOPE AND ADMINISTRATION; 101.3 Intent, 104.11 Alternative materials, design and methods of construction and equipment, **SECTION 105 PERMITS** 105.1 Required, 105.2 Work exempt from permit, **SECTION 107 SUBMITTAL DOCUMENTS** 107.1 General, 107.2.4 Exterior wall envelope, 107.3.4 Design professional in responsible charge, **SECTION 110 INSPECTIONS** 110.1 General, 110.3.1 Footing and foundation inspection, 110.3.2 Concrete slab and under-floor inspection, 110.3.7 Energy efficiency inspections, 110.3.8 Other inspections, 110.3.9 Special inspections, **SECTION 115 STOP WORK ORDER**.

CHAPTER 2 DEFINITIONS (multiple applicable references).

CHAPTER 7 FIRE AND SMOKE PROTECTION FEATURES; SECTION 703 FIRE-RESISTANCE RATINGS AND FIRE TESTS, 703.2 Fire-resistance ratings, 703.2.2 Combustible components, 703.3 Alternative methods for determining fire resistance, **SECTION 704 FIRE-RESISTANCE RATING OF STRUCTURAL MEMBERS**, 704.10 Exterior structural members, 705.4 Materials, 705.5 Fire-resistance ratings, **SECTION 719 THERMAL- AND SOUND-INSULATING MATERIALS**, 719.4 Loose-fill insulation, **SECTION 720 PRESCRIPTIVE FIRE RESISTANCE**, 720.1.2 Unit masonry protection, **SECTION 721 CALCULATED FIRE RESISTANCE**, 721.1 General, **TABLE 720.1(2) RATED FIRE-RESISTANCE PERIODS FOR VARIOUS WALLS AND PARTITIONS**, 721.3 Concrete masonry.

CHAPTER 8 INTERIOR FINISHES; SECTION 801 GENERAL, 801.8 Foam plastics, **SECTION 803 WALL AND CEILING FINISHES**, 803.4 Foam plastics, **SECTION 807 INSULATION**. **CHAPTER 12 INTERIOR ENVIRONMENT; SECTION 1207 SOUND TRANSMISSION**, 1207.2 Air-borne sound, 1207.2.1 Masonry, **SECTION 1210 SURROUNDING MATERIALS**, 1210.2 Walls and partitions, 1210.3 Showers.

CHAPTER 13 ENERGY EFFICIENCY; SECTION 1301 GENERAL, 1301.1.1 Criteria.

CHAPTER 14 EXTERIOR WALLS; SECTION 1403 PERFORMANCE REQUIREMENTS, 1403.2 Weather protection, **SECTION 1404 MATERIALS** 1404.4 Masonry, 1404.7 Glass-unit masonry, **SECTION 1405 INSTALLATION OF WALL COVERINGS**, 1405.2 Weather protection, 1405.3 Vapor retarders, 1405.4 Flashing, 1405.4.1 Exterior wall pockets, 1405.4.2 Masonry, 1405.5 Wood veneers (Comparative Requirements), 1405.6 Anchored masonry veneer (Comparative requirements or possible interior placement), 1405.7 Stone veneer (Comparative Requirements), 1405.8 Slab-type veneer (Comparative Requirements), 1405.9 Terra cotta (Comparative Requirements), 1405.10 Adhered masonry veneer, (Comparative Requirements), 1405.10.1 Interior adhered masonry veneers, 1405.11 Metal veneers (Comparative Requirements), 1405.12 Glass veneer (Comparative Requirements), 1405.13 Exterior windows and doors (Comparative Requirements), 1405.14 Vinyl siding (Comparative Requirements), 1405.15 Cement plaster (Comparative Requirements), 1405.16 Fiber-cement siding (Comparative Requirements), 1405.17 Fastening (More Comparative Requirements), **SECTION 1406 COMBUSTIBLE MATERIALS ON THE EXTERIOR SIDE OF EXTERIOR WALLS** (Comparative requirements), **SECTION 1407 METAL COMPOSITE MATERIALS (MCM)** (Comparative Requirements), **SECTION 1408 EXTERIOR INSULATION AND FINISH SYSTEMS (EIFS)**; Comparative requirements).

CHAPTER 15 ROOF ASSEMBLIES AND ROOFTOP STRUCTURES (Includes effects of scuppers, drains, and gutters – or their omissions; plumbing and drainage – including blockage and ice dams – affects lower masonry courses, leakage at interfaces with footing, foundation, and slab, as well as below-grade construction), **SECTION 1503 WEATHER PROTECTION**, 1503.1 General, 1503.2 Flashing, 1503.2.1 Locations, 1503.4 Roof drainage, 1503.4.1 Secondary drainage required, 1503.4.2 Scuppers, 1503.4.3 Gutters.

Table of Contents	
CHAPTER 1 SCOPE AND ADMINISTRATION	101.3 Intent, 104.11 Alternative materials, design and methods of construction and equipment, SECTION 105 PERMITS 105.1 Required, 105.2 Work exempt from permit, SECTION 107 SUBMITTAL DOCUMENTS 107.1 General, 107.2.4 Exterior wall envelope, 107.3.4 Design professional in responsible charge, SECTION 110 INSPECTIONS 110.1 General, 110.3.1 Footing and foundation inspection, 110.3.2 Concrete slab and under-floor inspection, 110.3.7 Energy efficiency inspections, 110.3.8 Other inspections, 110.3.9 Special inspections, SECTION 115 STOP WORK ORDER.
CHAPTER 2 DEFINITIONS	(multiple applicable references).
CHAPTER 7 FIRE AND SMOKE PROTECTION FEATURES; SECTION 703 FIRE-RESISTANCE RATINGS AND FIRE TESTS	703.2 Fire-resistance ratings, 703.2.2 Combustible components, 703.3 Alternative methods for determining fire resistance, SECTION 704 FIRE-RESISTANCE RATING OF STRUCTURAL MEMBERS, 704.10 Exterior structural members, 705.4 Materials, 705.5 Fire-resistance ratings, SECTION 719 THERMAL- AND SOUND-INSULATING MATERIALS, 719.4 Loose-fill insulation, SECTION 720 PRESCRIPTIVE FIRE RESISTANCE, 720.1.2 Unit masonry protection, SECTION 721 CALCULATED FIRE RESISTANCE, 721.1 General, TABLE 720.1(2) RATED FIRE-RESISTANCE PERIODS FOR VARIOUS WALLS AND PARTITIONS, 721.3 Concrete masonry.
CHAPTER 8 INTERIOR FINISHES; SECTION 801 GENERAL	801.8 Foam plastics, SECTION 803 WALL AND CEILING FINISHES, 803.4 Foam plastics, SECTION 807 INSULATION. CHAPTER 12 INTERIOR ENVIRONMENT; SECTION 1207 SOUND TRANSMISSION, 1207.2 Air-borne sound, 1207.2.1 Masonry, SECTION 1210 SURROUNDING MATERIALS, 1210.2 Walls and partitions, 1210.3 Showers.
CHAPTER 13 ENERGY EFFICIENCY; SECTION 1301 GENERAL	1301.1.1 Criteria.
CHAPTER 14 EXTERIOR WALLS; SECTION 1403 PERFORMANCE REQUIREMENTS	1403.2 Weather protection, SECTION 1404 MATERIALS 1404.4 Masonry, 1404.7 Glass-unit masonry, SECTION 1405 INSTALLATION OF WALL COVERINGS, 1405.2 Weather protection, 1405.3 Vapor retarders, 1405.4 Flashing, 1405.4.1 Exterior wall pockets, 1405.4.2 Masonry, 1405.5 Wood veneers (Comparative Requirements), 1405.6 Anchored masonry veneer (Comparative requirements or possible interior placement), 1405.7 Stone veneer (Comparative Requirements), 1405.8 Slab-type veneer (Comparative Requirements), 1405.9 Terra cotta (Comparative Requirements), 1405.10 Adhered masonry veneer, (Comparative Requirements), 1405.10.1 Interior adhered masonry veneers, 1405.11 Metal veneers (Comparative Requirements), 1405.12 Glass veneer (Comparative Requirements), 1405.13 Exterior windows and doors (Comparative Requirements), 1405.14 Vinyl siding (Comparative Requirements), 1405.15 Cement plaster (Comparative Requirements), 1405.16 Fiber-cement siding (Comparative Requirements), 1405.17 Fastening (More Comparative Requirements), SECTION 1406 COMBUSTIBLE MATERIALS ON THE EXTERIOR SIDE OF EXTERIOR WALLS (Comparative requirements), SECTION 1407 METAL COMPOSITE MATERIALS (MCM) (Comparative Requirements), SECTION 1408 EXTERIOR INSULATION AND FINISH SYSTEMS (EIFS); Comparative requirements).
CHAPTER 15 ROOF ASSEMBLIES AND ROOFTOP STRUCTURES	(Includes effects of scuppers, drains, and gutters – or their omissions; plumbing and drainage – including blockage and ice dams – affects lower masonry courses, leakage at interfaces with footing, foundation, and slab, as well as below-grade construction), SECTION 1503 WEATHER PROTECTION, 1503.1 General, 1503.2 Flashing, 1503.2.1 Locations, 1503.4 Roof drainage, 1503.4.1 Secondary drainage required, 1503.4.2 Scuppers, 1503.4.3 Gutters.

CHAPTER 16 STRUCTURAL DESIGN (In general, an awareness of the many different types of loads, geographic effects, and building categories – each affecting CMU walls requirements, and effect on costs, along with competitive wall requirements and effect on costs), 1603.1.6 Geotechnical information, 1603.1.9 Systems and components requiring special inspections for seismic resistance, 1603.1.7 Flood design data, **SECTION 1604 GENERAL DESIGN REQUIREMENTS**, 1604.2 Strength, 1604.3.4 Masonry, 1604.5 Occupancy category, **TABLE 1604.5 OCCUPANCY CATEGORY OF BUILDINGS AND OTHER STRUCTURES**, 1604.8 Anchorage, 1607.7 Loads on handrails, guards, grab bars, seats and vehicle barrier systems, 1607.7.3 Vehicle barrier systems, 1607.8 Impact loads, 1607.8.1 Elevators, 1607.8.2 Machinery, 1607.11.3 Landscaped roofs, 1607.13 Interior walls and partitions, **SECTION 1608, SNOW LOADS**, **SECTION 1609 WIND LOADS**, 1609.5 Roof systems, 1609.6.4 Design procedure, **SECTION 1610 SOIL LATERAL LOADS**, **SECTION 1611 RAIN LOADS**, **[P] FIGURE 1611.1 100-YEAR, 1-HOUR RAINFALL (INCHES)**, 1611.2 Ponding instability, 1611.3 Controlled drainage, **SECTION 1612 FLOOD LOADS**, **SECTION 1613 EARTHQUAKE LOADS**, **FIGURE 1613.5(1-14) MAXIMUM CONSIDERED EARTHQUAKE GROUND MOTION**.

CHAPTER 17 STRUCTURAL TESTS AND SPECIAL INSPECTIONS, SECTION 1703 APPROVALS, 1703.1 Approved agency, 1703.2 Written approval, **SECTION 1704 SPECIAL INSPECTIONS**, 1704.1.1 Statement of special inspections, 1704.3 Steel construction, 1704.4 Concrete construction, 1704.5 Masonry construction, **TABLE 1704.5.1 LEVEL 1 REQUIRED VERIFICATION AND INSPECTION OF MASONRY CONSTRUCTION**, **TABLE 1704.5.3 LEVEL 2 REQUIRED VERIFICATION AND INSPECTION OF MASONRY CONSTRUCTION**, 1704.5.1 Empirically designed masonry, glass unit masonry and masonry veneer in Occupancy Category IV, 1704.5.2 Engineered masonry in Occupancy Category I, II or III, 1704.5.3 Engineered masonry in Occupancy Category IV, 1704.6 Wood construction, 1704.7 Soils, 1704.8 Driven deep foundations, 1704.9 Cast-in-place deep foundations, 1704.10 Helical pile foundations, 1704.11 Vertical masonry foundation elements, 1704.12 Sprayed fire-resistant materials, 1704.13 Mastic and intumescent fire-resistant coatings, 1704.14 Exterior insulation and finish systems (EIFS), 1704.16 Special inspection for smoke control, **SECTION 1705 STATEMENT OF SPECIAL INSPECTIONS**,

CHAPTER 18 SOILS AND FOUNDATIONS; SECTION 1801 GENERAL; 1801.1 Scope, **SECTION 1803 GEOTECHNICAL INVESTIGATIONS**, 1803.1 General, 1803.3 Basis of investigation, 1803.5 Investigated conditions, 1803.5.1 Classification, 1803.5.2 Questionable soil, 1803.5.3 Expansive soil, 1803.5.4 Ground-water table, Exception, 1803.5.5 Deep foundations, 1803.5.6 Rock strata, 1803.5.8 Compacted fill material, 1803.5.9 Controlled low-strength material (CLSM), 1803.5.10 Alternate setback and clearance, 1803.5.11 Seismic Design Categories C through F, 1803.5.12 Seismic Design Categories D through F, 1803.6 Reporting, **SECTION 1804 EXCAVATION, GRADING AND FILL**, **SECTION 1805 DAMPPROOFING AND WATERPROOFING**, 1805.1 General, 1805.1.1 Story above grade plane, 1805.1.3 Ground-water control, 1805.2 Dampproofing, 1805.2.1 Floors, 1805.2.2 Walls, 1805.2.2.1 Surface preparation of walls, 1805.3 Waterproofing, 1805.3.1 Floors, 1805.3.2 Walls, 1805.3.2.1 Surface preparation of walls, 1805.3.3 Joints and penetrations, 1805.4 Subsoil drainage system, 1805.4.1 Floor base course, Exception, 1805.4.2 Foundation drain, 1805.4.3 Drainage discharge, **SECTION 1807 FOUNDATION WALLS, RETAINING WALLS AND EMBEDDED POSTS AND POLES**, 1807.1.5 Concrete and masonry foundation walls, Exception, 1807.1.6 Prescriptive design of concrete and masonry foundation walls, 1807.1.6.1 Foundation wall thickness, 1807.1.6.2.1 Seismic requirements, 1807.1.6.3 Masonry foundation walls, 1807.1.6.3.1 Alternative foundation wall reinforcement, 1807.1.6.3.2 Seismic requirements, 1807.2 Retaining walls, 1807.2.1 General, 1807.3 Embedded posts and poles (masonry bracing) 1808.5 Shifting or moving soils, 1808.6 Design for expansive soils, 1808.7 Foundations on or adjacent to slopes, 1808.9 Vertical masonry foundation elements, **SECTION 1809 SHALLOW FOUNDATIONS**, 1809.7 Prescriptive footings for light-frame construction (masonry unit footings) 1809.9 Masonry-unit footings, 1809.10 Pier and curtain wall foundations (includes masonry piers and foundations).

CHAPTER 19 CONCRETE; SECTION 1904 DURABILITY REQUIREMENTS, 1904.1 Water-cementitious materials ratio, 1904.2 Exposure categories and classes (sulfates, etc.), 1904.3 Concrete properties, **TABLE 1904.3 MINIMUM SPECIFIED COMPRESSIVE STRENGTH (f'c)** (relates to exposure, sulfates, etc.) 1904.4 Freezing and thawing exposures, 1904.5 Alternative cementitious materials for sulfate exposure.

CHAPTER 21 MASONRY

CHAPTER 22 STEEL; 2206.2 Design (anchorage; masonry in-fill needs be anchored one way or another).

CHAPTER 23 WOOD; 2304.10.2 Floor framing (on masonry), 2304.10.4 Floor decks (and masonry), 2304.11.2.3 Exterior walls



Table of Contents	
CHAPTER 16 STRUCTURAL DESIGN	1603.1.6 Geotechnical information, 1603.1.9 Systems and components requiring special inspections for seismic resistance, 1603.1.7 Flood design data, SECTION 1604 GENERAL DESIGN REQUIREMENTS, 1604.2 Strength, 1604.3.4 Masonry, 1604.5 Occupancy category, TABLE 1604.5 OCCUPANCY CATEGORY OF BUILDINGS AND OTHER STRUCTURES, 1604.8 Anchorage, 1607.7 Loads on handrails, guards, grab bars, seats and vehicle barrier systems, 1607.7.3 Vehicle barrier systems, 1607.8 Impact loads, 1607.8.1 Elevators, 1607.8.2 Machinery, 1607.11.3 Landscaped roofs, 1607.13 Interior walls and partitions, SECTION 1608, SNOW LOADS, SECTION 1609 WIND LOADS, 1609.5 Roof systems, 1609.6.4 Design procedure, SECTION 1610 SOIL LATERAL LOADS, SECTION 1611 RAIN LOADS, [P] FIGURE 1611.1 100-YEAR, 1-HOUR RAINFALL (INCHES), 1611.2 Ponding instability, 1611.3 Controlled drainage, SECTION 1612 FLOOD LOADS, SECTION 1613 EARTHQUAKE LOADS, FIGURE 1613.5(1-14) MAXIMUM CONSIDERED EARTHQUAKE GROUND MOTION.
CHAPTER 17 STRUCTURAL TESTS AND SPECIAL INSPECTIONS, SECTION 1703 APPROVALS	1703.1 Approved agency, 1703.2 Written approval, SECTION 1704 SPECIAL INSPECTIONS, 1704.1.1 Statement of special inspections, 1704.3 Steel construction, 1704.4 Concrete construction, 1704.5 Masonry construction, TABLE 1704.5.1 LEVEL 1 REQUIRED VERIFICATION AND INSPECTION OF MASONRY CONSTRUCTION, TABLE 1704.5.3 LEVEL 2 REQUIRED VERIFICATION AND INSPECTION OF MASONRY CONSTRUCTION, 1704.5.1 Empirically designed masonry, glass unit masonry and masonry veneer in Occupancy Category IV, 1704.5.2 Engineered masonry in Occupancy Category I, II or III, 1704.5.3 Engineered masonry in Occupancy Category IV, 1704.6 Wood construction, 1704.7 Soils, 1704.8 Driven deep foundations, 1704.9 Cast-in-place deep foundations, 1704.10 Helical pile foundations, 1704.11 Vertical masonry foundation elements, 1704.12 Sprayed fire-resistant materials, 1704.13 Mastic and intumescent fire-resistant coatings, 1704.14 Exterior insulation and finish systems (EIFS), 1704.16 Special inspection for smoke control, SECTION 1705 STATEMENT OF SPECIAL INSPECTIONS,
CHAPTER 18 SOILS AND FOUNDATIONS; SECTION 1801 GENERAL	1801.1 Scope, SECTION 1803 GEOTECHNICAL INVESTIGATIONS, 1803.1 General, 1803.3 Basis of investigation, 1803.5 Investigated conditions, 1803.5.1 Classification, 1803.5.2 Questionable soil, 1803.5.3 Expansive soil, 1803.5.4 Ground-water table, Exception, 1803.5.5 Deep foundations, 1803.5.6 Rock strata, 1803.5.8 Compacted fill material, 1803.5.9 Controlled low-strength material (CLSM), 1803.5.10 Alternate setback and clearance, 1803.5.11 Seismic Design Categories C through F, 1803.5.12 Seismic Design Categories D through F, 1803.6 Reporting, SECTION 1804 EXCAVATION, GRADING AND FILL, SECTION 1805 DAMPPROOFING AND WATERPROOFING, 1805.1 General, 1805.1.1 Story above grade plane, 1805.1.3 Ground-water control, 1805.2 Dampproofing, 1805.2.1 Floors, 1805.2.2 Walls, 1805.2.2.1 Surface preparation of walls, 1805.3 Waterproofing, 1805.3.1 Floors, 1805.3.2 Walls, 1805.3.2.1 Surface preparation of walls, 1805.3.3 Joints and penetrations, 1805.4 Subsoil drainage system, 1805.4.1 Floor base course, Exception, 1805.4.2 Foundation drain, 1805.4.3 Drainage discharge, SECTION 1807 FOUNDATION WALLS, RETAINING WALLS AND EMBEDDED POSTS AND POLES, 1807.1.5 Concrete and masonry foundation walls, Exception, 1807.1.6 Prescriptive design of concrete and masonry foundation walls, 1807.1.6.1 Foundation wall thickness, 1807.1.6.2.1 Seismic requirements, 1807.1.6.3 Masonry foundation walls, 1807.1.6.3.1 Alternative foundation wall reinforcement, 1807.1.6.3.2 Seismic requirements, 1807.2 Retaining walls, 1807.2.1 General, 1807.3 Embedded posts and poles (masonry bracing) 1808.5 Shifting or moving soils, 1808.6 Design for expansive soils, 1808.7 Foundations on or adjacent to slopes, 1808.9 Vertical masonry foundation elements, SECTION 1809 SHALLOW FOUNDATIONS, 1809.7 Prescriptive footings for light-frame construction (masonry unit footings) 1809.9 Masonry-unit footings, 1809.10 Pier and curtain wall foundations (includes masonry piers and foundations).
CHAPTER 19 CONCRETE; SECTION 1904 DURABILITY REQUIREMENTS	1904.1 Water-cementitious materials ratio, 1904.2 Exposure categories and classes (sulfates, etc.), 1904.3 Concrete properties, TABLE 1904.3 MINIMUM SPECIFIED COMPRESSIVE STRENGTH (f'c) (relates to exposure, sulfates, etc.) 1904.4 Freezing and thawing exposures, 1904.5 Alternative cementitious materials for sulfate exposure.
CHAPTER 21 MASONRY	
CHAPTER 22 STEEL	2206.2 Design (anchorage; masonry in-fill needs be anchored one way or another).
CHAPTER 23 WOOD	2304.10.2 Floor framing (on masonry), 2304.10.4 Floor decks (and masonry), 2304.11.2.3 Exterior walls

below grade (and masonry), 2304.11.2.5 Girder ends (and masonry walls), 2304.11.2.7 Posts or columns (and masonry), 2304.12 Long-term loading (and masonry), TABLE 2306.6 (a. masonry bracing limit), TABLE 2306.7 (a. masonry shear load), 2308.3.3 Sill anchorage (masonry foundation)

CHAPTER 25 GYPSUM BOARD AND PLASTER; SECTION 2503 INSPECTION (for these purposes, as interior finish or comparative requirements), **SECTION 2504 VERTICAL AND HORIZONTAL ASSEMBLIES; SECTION 2505 SHEAR WALL CONSTRUCTION** (comparative requirements), **SECTION 2506 GYPSUM BOARD MATERIALS** (as interior finish or comparative requirements), **SECTION 2507 LATHING AND PLASTERING** (as interior finish), **SECTION 2508 GYPSUM CONSTRUCTION** (as interior finish or comparative requirements), 2508.2 Limitations, 2508.2.1 Weather protection, **SECTION 2509 GYPSUM BOARD IN SHOWERS AND WATER CLOSETS** (as interior finish or comparative requirements), **SECTION 2510 LATHING AND FURRING FOR CEMENT PLASTER (STUCCO)** (as interior finish or comparative requirements), **SECTION 2511 INTERIOR PLASTER** (as interior finish or comparative requirements),

CHAPTER 26 PLASTIC; SECTION 2601 GENERAL; 2601.1 Scope (for these purposes, primarily as Energy Conservation; insulation. Also as comparative requirements.), **SECTION 2603 FOAM PLASTIC INSULATION,** 2603.4 Thermal barrier, 2603.4.1 Thermal barrier not required, 2603.4.1.1 Masonry or concrete construction, 2603.4.1.11 Interior trim, 2603.4.1.12 Interior signs, 2603.5 Exterior walls of buildings of any height (comparative requirements), 2603.5.3 Potential heat, 2603.5.6 Label required, 2603.5.7 Ignition, Exception (as relating to masonry covering), 2603.7 Plenums (vertical wall application), 2603.8 Protection against termites (comparative requirements and separation distances), Exceptions (as masonry applicable), **SECTION 2604 INTERIOR FINISH AND TRIM, SECTION 2613 REFLECTIVE PLASTIC CORE INSULATION.**

CHAPTER 28 MECHANICAL SYSTEMS; SECTION 2801 GENERAL; 2801.1 Scope.

CHAPTER 29 PLUMBING SYSTEMS; SECTION 2901 GENERAL, [P] 2901.1 Scope.

CHAPTER 30 ELEVATORS AND CONVEYING SYSTEMS; SECTION 3002 HOISTWAY ENCLOSURES, 3002.1 Hoistway enclosure protection (as fire-resistance requirements). **SECTION 3006 MACHINE ROOMS,** 3006.4 Machine rooms and machinery spaces (as fire-resistance requirements), **SECTION 3007 FIRE SERVICE ACCESS ELEVATOR,** 3007.2 Hoistway enclosures protection (as fire-resistance requirements), **SECTION 3008 OCCUPANT EVACUATION ELEVATORS,** 3008.9 Hoistway enclosure protection, (as fire-resistance requirements),

CHAPTER 31 SPECIAL CONSTRUCTION; SECTION 3104 PEDESTRIAN WALKWAYS AND TUNNELS; 3104.3 Construction, (as fire-resistance requirements), 3104.5 Fire barriers between pedestrian walkways and Buildings, 3104.10 Tunneled walkway (as fire resistance requirements), **SECTION 3106 MARQUEES,** 3106.5 Construction (as fire and deterioration resistance requirements), **SECTION 3109 SWIMMING POOL ENCLOSURES AND SAFETY DEVICES,** 3109.3 Public swimming pools (as fencing requirements), 3109.4 Residential swimming pools (as barrier requirements),

CHAPTER 32 ENCROACHMENTS INTO THE PUBLIC RIGHT-OF-WAY; SECTION 3201 GENERAL, 3201.4 Drainage (as affects implied project ground-level construction and drainage), 3202.2 Encroachments above grade and below 8 feet in height (as restrictions and allowances),

CHAPTER 33 SAFEGUARDS DURING CONSTRUCTION; SECTION 3301 GENERAL, 3301.1 Scope, **SECTION 3303 DEMOLITION, 3303.5** Water accumulation (applies both ways), **SECTION 3307 PROTECTION OF ADJOINING PROPERTY** (applies both ways).

International Energy Conservation Code ("IECC"; especially 2006 and 2009); INTERNATIONAL CODE COUNCIL, INC., 4051 West Flossmoor Road, Country Club Hills, IL 60478; including but not limited to:



The image shows a small thumbnail of a 'Table of Contents' page. It lists various sections and chapters of the code, such as 'CHAPTER 25 GYPSUM BOARD AND PLASTER', 'CHAPTER 26 PLASTIC', 'CHAPTER 28 MECHANICAL SYSTEMS', 'CHAPTER 29 PLUMBING SYSTEMS', 'CHAPTER 30 ELEVATORS AND CONVEYING SYSTEMS', 'CHAPTER 31 SPECIAL CONSTRUCTION', 'CHAPTER 32 ENCROACHMENTS INTO THE PUBLIC RIGHT-OF-WAY', and 'CHAPTER 33 SAFEGUARDS DURING CONSTRUCTION'. The page is organized into two columns with corresponding page numbers.

CHAPTER 1 ADMINISTRATION, 101.3 Intent,

CHAPTER 2 DEFINITIONS,

CHAPTER 3 CLIMATE ZONES,

CHAPTER 5 COMMERCIAL ENERGY EFFICIENCY, SECTION 502 BUILDING ENVELOPE REQUIREMENTS, TABLE 502.1.2 BUILDING ENVELOPE REQUIREMENTS OPAQUE ELEMENT, MAXIMUM U-FACTORS, TABLE 502.2(1) BUILDING ENVELOPE REQUIREMENTS – OPAQUE ASSEMBLIES (Minimum R-Values), 502.2.4 Below-grade walls, 502.2.6 Slabs on grade, 502.4 Air leakage (Mandatory), 502.4.3 Sealing of the building envelope, SECTION 506 TOTAL BUILDING PERFORMANCE, 506.2 Mandatory requirements, 506.3 Performance-based compliance, 506.4 Documentation, 506.5 Calculation procedure, 506.6 Calculation software tools, 506.6.1 Specific approval

American Society of Heating and Refrigeration Engineers Standard 90.1 ("ASHRAE 90.1", or "90.1"; especially 2004 and 2007 editions) (including Normative Appendices as well as Informative Appendices), American Society of Heating and Refrigeration Engineers Inc., 1791 Tullie Circle NE, Atlanta, GA 30329.

3.0 DEFINITIONS, ABBREVIATIONS, AND ACRONYMS, 3.2 Definitions,

4.0 ADMINISTRATION AND ENFORCEMENT, 4.1.7 Normative Appendices, 4.2.1 Compliance Paths,

5.0 GENERAL 5.1.4 Climate, 5.2 Compliance Paths, 5.2.1 a. 5.5 Prescriptive Building Envelope Option, 5.2.1 b. 5.6 Building Envelope Trade-Off Option, 5.2.2 (as relates to Energy Cost Budget), 5.4 Mandatory Provisions, 5.4.1 Insulation, 5.4.3 Air Leakage, 5.4.3.1 Building Envelope Sealing, 5.5 Prescriptive Building Envelope Option, Building Envelope Requirements for Climate Zones Tables 5.5-1 through 8, 5.5.3.2 Above-Grade Wall Insulation, 5.5.3.3 Below-Grade Wall Insulation, 5.5.3.4 Floor Insulation, 5.5.3.5 Slab-on-Grade Insulation, 5.6 Building Envelope Trade-Off Option.

NORMATIVE APPENDIX A RATED R-VALUE OF INSULATION AND ASSEMBLY U-FACTOR, C-FACTOR, AND F-FACTOR DETERMINATION, A.1 GENERAL, A.3 ABOVE-GRADE WALLS, A.4 BELOW-GRADE WALLS, A.5 FLOORS, A.6 SLAB-ON-GRADE FLOORS, A.9 DETERMINATION OF ALTERNATE ASSEMBLY U-FACTORS, C-FACTORS, OR HEAT CAPACITIES,

NORMATIVE APPENDIX B-BUILDING ENVELOPE CLIMATE CRITERIA,

NORMATIVE APPENDIX C METHODOLOGY FOR BUILDING ENVELOPE TRADE-OFF OPTION IN SUBSECTION 5.6.

International Mechanical Code ("IMC") (especially 2006 and 2009); INTERNATIONAL CODE COUNCIL, INC., 4051 West Flossmoor Road, Country Club Hills, IL 60478; Including but not limited to:

CHAPTER 2 DEFINITIONS, SECTION 202 GENERAL DEFINITIONS (especially AIR, CONDENSATE, CONDITIONED SPACE, ENVIRONMENTAL AIR, NATURAL VENTILATION, OUTDOOR AIR, PLENUM, RECIRCULATED AIR, RETURN AIR, SUPPLY AIR, VENTILATION AIR),

CHAPTER 3 GENERAL REGULATIONS, SECTION 304 INSTALLATION, 304.10 Clearances from grade (possible affect on masonry wall base course placement), 306.5 Equipment and appliances on roofs or elevated structures (affects wall loads), SECTION 307 CONDENSATE DISPOSAL(moisture source on, in, or adjacent to building).

Table of Contents	
CHAPTER 1 ADMINISTRATION	101.3
CHAPTER 2 DEFINITIONS	202
CHAPTER 3 GENERAL REGULATIONS	304
CHAPTER 4 MECHANICAL SYSTEMS	401
CHAPTER 5 COMMERCIAL ENERGY EFFICIENCY	502
CHAPTER 6 MECHANICAL SYSTEMS	601
CHAPTER 7 PLUMBING	701
CHAPTER 8 GAS PIPING	801
CHAPTER 9 ELECTRICAL	901
CHAPTER 10 SAFETY	1001
CHAPTER 11 GENERAL	1101
CHAPTER 12 SUPPLEMENTAL	1201
CHAPTER 13	1301
CHAPTER 14	1401
CHAPTER 15	1501
CHAPTER 16	1601
CHAPTER 17	1701
CHAPTER 18	1801
CHAPTER 19	1901
CHAPTER 20	2001
CHAPTER 21	2101
CHAPTER 22	2201
CHAPTER 23	2301
CHAPTER 24	2401
CHAPTER 25	2501
CHAPTER 26	2601
CHAPTER 27	2701
CHAPTER 28	2801
CHAPTER 29	2901
CHAPTER 30	3001
CHAPTER 31	3101
CHAPTER 32	3201
CHAPTER 33	3301
CHAPTER 34	3401
CHAPTER 35	3501
CHAPTER 36	3601
CHAPTER 37	3701
CHAPTER 38	3801
CHAPTER 39	3901
CHAPTER 40	4001
CHAPTER 41	4101
CHAPTER 42	4201
CHAPTER 43	4301
CHAPTER 44	4401
CHAPTER 45	4501
CHAPTER 46	4601
CHAPTER 47	4701
CHAPTER 48	4801
CHAPTER 49	4901
CHAPTER 50	5001
CHAPTER 51	5101
CHAPTER 52	5201
CHAPTER 53	5301
CHAPTER 54	5401
CHAPTER 55	5501
CHAPTER 56	5601
CHAPTER 57	5701
CHAPTER 58	5801
CHAPTER 59	5901
CHAPTER 60	6001
CHAPTER 61	6101
CHAPTER 62	6201
CHAPTER 63	6301
CHAPTER 64	6401
CHAPTER 65	6501
CHAPTER 66	6601
CHAPTER 67	6701
CHAPTER 68	6801
CHAPTER 69	6901
CHAPTER 70	7001
CHAPTER 71	7101
CHAPTER 72	7201
CHAPTER 73	7301
CHAPTER 74	7401
CHAPTER 75	7501
CHAPTER 76	7601
CHAPTER 77	7701
CHAPTER 78	7801
CHAPTER 79	7901
CHAPTER 80	8001
CHAPTER 81	8101
CHAPTER 82	8201
CHAPTER 83	8301
CHAPTER 84	8401
CHAPTER 85	8501
CHAPTER 86	8601
CHAPTER 87	8701
CHAPTER 88	8801
CHAPTER 89	8901
CHAPTER 90	9001
CHAPTER 91	9101
CHAPTER 92	9201
CHAPTER 93	9301
CHAPTER 94	9401
CHAPTER 95	9501
CHAPTER 96	9601
CHAPTER 97	9701
CHAPTER 98	9801
CHAPTER 99	9901
CHAPTER 100	10001

CHAPTER 4 VENTILATION SECTION 402 NATURAL VENTILATION, [B] 402.2 Ventilation area required, [B] 402.4 Openings below grade (affects wall penetrations, drainage, moisture resistance, dampproofing, etc), 403.4 Exhaust ventilation (affects net Energy Conservation, wall penetrations and weather protection, additional supply air and related penetrations, etc.),

CHAPTER 5 EXHAUST SYSTEMS, 501.2.2 Exhaust opening protection (affects net Energy Conservation, wall penetrations and weather protection, additional supply air and related penetrations, etc).

International Plumbing Code ("IPC"; especially 2006 and 2009) INTERNATIONAL CODE COUNCIL, INC., 4051 West Flossmoor Road, Country Club Hills, IL 60478; Including but not limited to:

CHAPTER 2 DEFINITIONS, SECTION 202, GENERAL DEFINITIONS (ACCESS (TO), WASTE),

CHAPTER 3 GENERAL REGULATIONS, SECTION 314; CONDENSATE DISPOSAL; [M] 314.2.1 Condensate disposal (additional potential source of moisture or waste at walls, base courses, footings, slabs, soil, etc.),

CHAPTER 4 FIXTURES, FAUCETS AND FIXTURE FITTINGS, SECTION 417 SHOWERS; 417.4 Shower compartments; 417.4.1 Wall area,

CHAPTER 6 WATER SUPPLY AND DISTRIBUTION, SECTION 605 MATERIALS, JOINTS AND CONNECTIONS; 605.1 Soil and ground water (emphasizing problem soil identification, remediation),

CHAPTER 9 VENTS, SECTION 904 VENT TERMINALS; 904.6 Extension through the wall (wall penetration),

CHAPTER 11 STORM DRAINAGE, SECTION 1102 STORM DRAINAGE, 1101.2 Where required, 1101.7 Roof design (note design assumptions), SECTION 1106 SIZE OF CONDUCTORS, LEADERS AND STORM DRAINS, 1106.1 General (Similar design basis as IBC ?), 1106.5 Parapet wall scupper location (wall penetration), 1106.6 Size of roof gutters (collected rain water to drain potentially at footing, foundation, base course area), SECTION 1107 SECONDARY (EMERGENCY) ROOF DRAINS, 1107.1 Secondary drainage required, 1107.2 Separate systems required (overflow to footing, foundation, base course area).

TMS 402/ACI 530/ASCE 5 and Commentary ("TMS 402", "TMS", or "MSJC"; Masonry Code; Building Code Requirements for Masonry Structures; especially 2005 and 2008 editions); The Masonry Society, 3970 Broadway, Suite 201-D, Boulder, CO 80304-1135; 105 South Sunset, Suite Q, Longmont, CO 80501.

TMS 602/ACI 530.1/ASCE 6 and Commentary ("TMS 602", "TMS" or "MSJC"; Masonry Specifications; Specifications for Masonry Structures; especially 2005 and 2008 editions); The Masonry Society, 3970 Broadway, Suite 201-D, Boulder, CO 80304-1135; 105 South Sunset, Suite Q, Longmont, CO 80501.

ASTM International Specifications, Test Methods, and Practices; ("ASTM"; as applicable by Code, Standard, or Specification; more recent editions), ASTM International, Barr Harbor Drive, PO Box C700, West Conshohocken, PA 19428-2959, Including **but** not limited to:



A small thumbnail image of a table of contents page, showing a list of sections and their corresponding page numbers. The text is too small to read clearly, but it appears to be a standard table of contents layout.

ASTM C 90 Standard Specification for Loadbearing Concrete Masonry Units,

ASTM C 140 Standard Test Methods for Sampling and Testing Concrete Masonry Units and Related Units.

NCMA TEK MANUAL; NATIONAL CONCRETE MASONRY ASSOCIATION, 13750 Sunrise Valley Drive, Herndon, Virginia 20171, www.ncma.org, publications@ncma.org.

NCMA DETAILS; NATIONAL CONCRETE MASONRY ASSOCIATION, 13750 Sunrise Valley Drive, Herndon, Virginia 20171, www.ncma.org, publications@ncma.org.

NCMA Fire Energy and Sound Calculator; NATIONAL CONCRETE MASONRY ASSOCIATION 13750 Sunrise Valley Drive, Herndon, Virginia 20171, www.ncma.org publications@ncma.org.



A small thumbnail image of a 'Table of Contents' page, showing a list of items and their corresponding page numbers. The text is too small to read clearly, but the layout is typical of a document's table of contents.

Solutions Available Nationwide

The Concrete Products Group LLC (CPG) consists of regional market leaders in the concrete products industry. The CPG is organized to provide consistent, top-quality products to regional and national customers. Our products are produced with consistent specifications and production expertise.



INNOVATIVE CONCRETE
MASONRY SYSTEMS

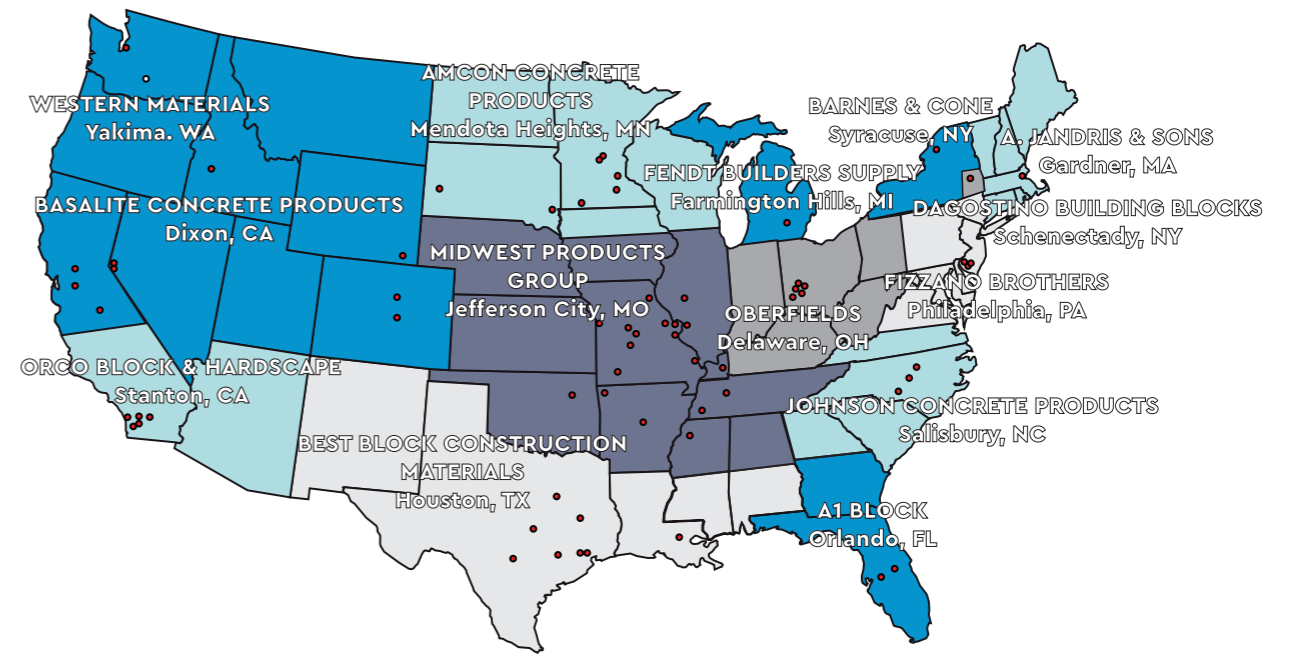

Manufacturing Locations

A-1 BLOCK
1617 South
Division Avenue
Orlando, FL 32805

A. JANDRIS & SONS
202 High St.
Gardner, MA
01440

**AMCON CONCRETE PROD-
UCTS, LLC**
P.O. Box 546
2211 Hwy 10 South
St. Cloud, MN
56302-0546

BARNES & CONE
P.O. Box 280
5894 Court St. Rd.
Syracuse, NY
13206-0280

**BASALITE CONCRETE
PRODUCTS LLC**
605 Industrial Way
Dixon, CA
95620

**DAGOSTINO BUILDING
BLOCKS, INC.**
1111 Altamont Avenuw
Schenectady, NY 12303

**FENDT BUILDERS
SUPPLY**
22005 Gill Rd,
Farmington, MI
48335

**FIZZANO BROTHERS
CONCRETE
PRODUCTS, INC.**
1776 Chester Pike
Crum Lynne, PA
19022-1299

**BEST BLOCK
7620 Washington Ave.
Houston, TX
77007**

**JOHNSON CONCRETE
COMPANY**
217 Klumac Road
Salisbury, NC 28144

**MIDWEST
PRODUCTS GROUP**
12901 St. Charles Rock Rd.
Bridgeton, MO
63044-2485

OBERFIELDS, LLC
P.O. Box 362
528 London Rd.
Delaware, OH 43015

ORCO BLOCK & HARDSCAPE
11100 Beach Blvd.
Stanton, CA
90680-0129

**WESTERN
MATERIALS
COMPANY**
1202 South First Street
Yakima, WA 98901

www.concreteproductsgroup.com

800-789-0872

© Concrete Products Group, LLC
All rights reserved. RD 01082020