

ANCHORED VENEER DESIGN MANUAL

ABRI™ Masonry Veneer
Spec-Brik® Veneer

Prepared By:
David T. Biggs, P.E., S.E.
Biggs Consulting Engineering PLLC



CONCRETE PRODUCTS GROUP

INNOVATIVE CONCRETE MASONRY SYSTEMS

ANCHORED VENEER DESIGN MANUAL

Prepared for:

Concrete Products Group (CPG)

12901 St Charles Rock Rd.

Bridgeton, MO 63044

www.concreteproductsgroup.com

Contact: Mr. William Dawson, 612-859-3340

Prepared by:

David T. Biggs, P.E., S.E.

Biggs Consulting Engineering PLLC

26F Congress St, #305

Saratoga Springs, NY 12866

www.biggsconsulting.net

3-27-2017

Table of Contents

Introduction	3.
Materials	5.
Movement Joints	7.
Wind and Seismic Limitations	9.
Concrete Products Group Design Solution, Tie and Anchor Selection	11.
Veneer Calculator	14.
Shelf Angle Supports	17.
Acknowledgements	22.

Introduction

Architects are specifying ever increasing amounts of insulation in the cavities of masonry walls. Until recently, 2 inches of insulation was relatively common. Today, the insulation could be as much as 6 to 7 inches.

With the increase in insulation and cavity size, architects and engineers are faced with some practical problems in achieving cavities that could be as large as 9 inches to provide for both the insulation and air space (Figure 1). Specifically, there are the issues of providing anchored veneer ties and anchors and shelf angle support for the anchored veneer.

Note: Continuous rigid insulation is shown on this figure to illustrate that the veneer anchorage can accommodate insulation. It is not intended to imply that continuous insulation is required. Unlike for steel framed walls, ASHRAE 90.1 does not mandate continuous insulation for load bearing masonry buildings. The designer of masonry buildings may demonstrate compliance without continuous insulation based on the building envelope as a whole, rather than on the prescriptive component-by-component basis.

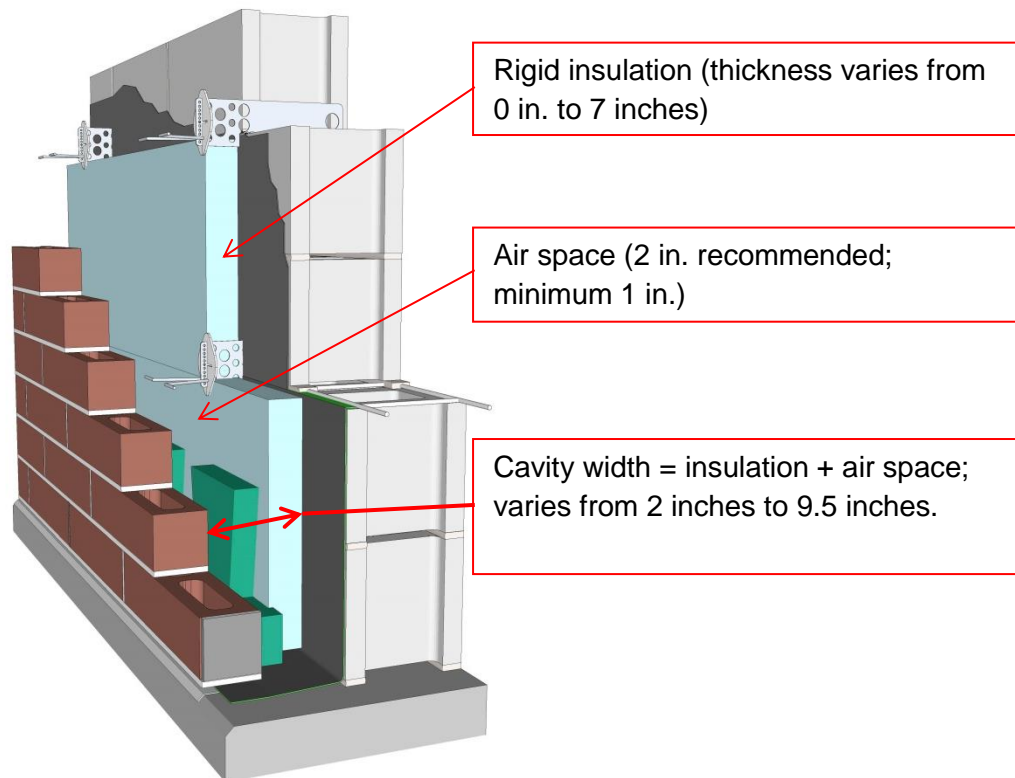

Figure 1 – Cavity wall with CMU

The need for veneer ties and anchors is mandated by the masonry standard, *Building Code Requirements for Masonry Structures* (TMS 402-13/ACI 530-13/ASCE 5-13). Chapter 12, Veneer provides two methods for designing anchored masonry veneers, either rationally by Section 12.2.1 or

detailed by the prescriptive requirements of Section 12.2.2. While there is a rational method, the criteria are quite general. Thus, most engineers follow the prescriptive method.

Concrete Products Group (CPG) provides this manual to provide guidance for designers to develop veneer anchoring criteria for concrete masonry veneers produced and distributed by CPG. For this manual, the prescriptive method will be used with the exception of cavity size. Ties and anchors will be discussed specifically for CMU and cold-formed metal framing (CFMF) backup; wood framing is not included. Code references provided in the document refer to TMS 402-13 unless noted otherwise.

Materials

Masonry Units

Anchored veneer must meet specific requirements.

1. TMS Section 12.2.2.4:
The minimum thickness must be at least 2 5/8 in. (66.7 mm)
2. TMS Sections 12.2.2.3.1.4 and 12.2.2.3.1.5:
A maximum veneer weight allowed is 40 psf for units supported by wood studs or wood framing.

TMS 402 does not limit the maximum weight of anchored veneer units when supported by other materials such as masonry, concrete or CFMF. This is a weakness in the standard in that it prescribes the required spacing for ties and anchors for seismic conditions, but does not limit the seismic weight (weight of the units).

3. Materials: Most CPG veneer units meet one of the following:
 - a. ASTM C90-14 *Standard Specification for Loadbearing Concrete Masonry Units* and can be hollow or solid. According to ASTM C90, solid units may have up to 25% void area as cores.
 - b. ASTM C1634-15, *Standard Specification for Concrete Facing Brick*.
4. Veneer unit sizes: In accordance with TMS 402, Section 12.2.2.4, CMU veneer units must be at least 2 5/8 inches in actual thickness. Typically, they are manufactured 3 5/8 inches to 4 inches thick for detailing consistency with clay brick veneer units.

The length and height of CMU veneer units can vary from one manufacturer to another. Theoretically, the height of the units can be as large as the maximum vertical spacing of the veneer anchors and ties. The length is determined by practical considerations such as manufacturing, aesthetics and handling weight.

5. Veneer unit weight: This manual is based upon an average veneer unit weight in conformance with NCMA TEK 14-13B, *CONCRETE MASONRY WALL WEIGHTS*, Table 2 - 4-in. Single Wythe Wall Weights—Half-High Units. The maximum average wall weight for 4-in. nominal solid units is 42 psf based upon 135 pcf density concrete. Should hollow units or lower densities be provided, the unit weight could be as low as 20 psf.

Using a maximum average wall weight of 42 psf does two things:

- a. It sets a limit for this manual.
 - b. It approximates the code maximum for veneers attached to wood.
6. ASTM C90 imposes an additional requirement that the maximum allowable shrinkage must be limited to 0.065%.

Mortar

ASTM C270 is the standard for all masonry mortars. ASTM C270, *Standard Specification for Mortar for Unit Masonry* provides TABLE X1.1 *Guide for the Selection of Masonry Mortars* which provides recommendations for mortar selection. Typically, Type S mortar is specified for structural masonry and Type N is specified for veneers. Designers must determine the appropriate mortar type for their application.

Reinforcement

Horizontal joint reinforcement is governed by ASTM A951/A951M-11, *Standard Specification for Steel Wire for Masonry Joint Reinforcement*. For anchored veneer, single wire or ladder-type reinforcement can be used. The reinforcement should be either hot-dipped galvanized, epoxy coated, or stainless steel dependent upon the environmental conditions.

Ties and anchors

Masonry standards require all anchored veneer ties and anchors be metallic (TMS 602, Articles 2.4 D and 2.4 E). Corrosion protection is required of all anchors and ties (TMS 602, Article 2.4 F).

Movement Joints

Movement joints in CMU wall assemblies are commonly referred to as control joints. These movements can be either reversible or non-reversible. Reversible movements include changes due to thermal effects and stress. Irreversible movements include drying shrinkage. Unlike clay masonry, CMU does not undergo irreversible moisture growth expansion. CMU veneer must accommodate these movements as well structural frame movement.

The National Concrete Masonry Association offers several TEK Notes that address control joints (movement joints) in concrete masonry walls. Under certain conditions, architects and engineers can use either reinforcement in bond beams or horizontal joint reinforcement to control cracking and extend the spacing between movement joints. For CMU veneer, horizontal joint reinforcement is recommended per NCMA TEK Note 10-4, *Crack Control for Concrete Brick and Other Concrete Masonry Veneers*, 2001.

There are two methods for determining the vertical control joint spacing, the Empirical Method and the Engineered Method. These are outlined in:

TEK 10-1a, Crack Control in Concrete Masonry Walls

TEK 10-2c, Control Joints for Concrete Masonry Walls – Empirical Method

TEK10-3, Control Joints for Concrete Masonry Walls - Alternative Engineered Method

Engineers are encouraged to study these documents for developing a layout for the movement joints using Hi-R and Hi-R H systems.

In *TEK 10-4*, control joints for residential veneers are recommended at a length to height ratio of 1.5 or 20 ft whichever is less. Joint reinforcement at 16 in. on center is recommended.

As noted in *TEK 10-1a*, control joints “are essentially vertical separations built into the wall to reduce restraint and permit longitudinal movement. Because shrinkage cracks in concrete masonry are an aesthetic rather than a structural concern, control joints are typically only required in walls where shrinkage cracking may detract from the appearance or where water penetration may occur.”

From the Empirical Method of *TEK 10-2c*, the maximum recommended distance between vertical joints for the veneer wythe without openings and with horizontal joint reinforcement of 0.025 in²/ft of height is the lesser of a) 25 ft or b) a length to height ratio of 1.5. The joint reinforcement uses 2-#9 wire longitudinal wires and must be spaced not to exceed 16 inches on center vertically.

From the Engineered Method of *TEK 10-3*, the maximum recommended distance between vertical joints is dependent upon the crack control coefficient (CCC) of the CMU. Table 1 in *TEK 10-3* tabulates the values based upon CCC = 0.0010 and 0.0015.

For CCC = 0.0010, the maximum recommended distance between vertical joints is the lesser of a) 25 ft or b) a length to height ratio of 2.5.

For $CCC = 0.0015$, the maximum recommended distance between vertical joints is the lesser of a) 20 ft or b) a length to height ratio of 2.0. The reinforcement required is $0.007 \times 3,625(12) = 0.030 \text{ in}^2$ per foot of height which is 2 - #9 wire longitudinal wires spaced not to exceed 12 inches on center vertically.

Unless CCC test data is provided, CPG recommends that designers of commercial projects use the Engineered Method of *TEK-10-3* for $CCC = 0.0015$. If joint reinforcement is not used, the recommendation is to reduce the control spacing by one-half as noted by Footnote 4, Table 1, *TEK 10-3*.

The previous recommendations primarily address shrinkage and thermal effects. The designer needs to accommodate structural frame movement as well.

Wind and Seismic Limitations

The prescriptive method requires several limitations for wind and seismic. The TMS 402 criteria are listed along with several comments.

1. TMS Section 12.2.2.1:

The wind velocity pressure, q_z , shall not exceed 40 psf (1.92 kPa) as given in ASCE 7 without further restrictions. No limitations are given for the building height.

Note: From ASCE 7-10, $q_z = 0.00256 K_z K_{zt} K_d V^2$ (lb/ft²) (ASCE 7- 10, Eq. 30.3-1)

This equation is the velocity pressure and is related to height through the term K_z . But, the velocity pressure does not represent the design wind pressure on the buildings. Refer to ASCE for the definition and use of the design wind pressure.

2. TMS Section 12.2.2.11:

In areas where the velocity pressure, q_z , exceeds 40 psf (1.92 kPa) but does not exceed 55 psf (2.63 kPa) and the building's mean roof height is less than or equal to 60 ft (18.3 m):

- (a) Reduce the maximum wall area supported by each anchor to 70 percent of that required in Sections 12.2.2.5.6.1 and 12.2.2.5.6.2.
- (b) Space anchors at a maximum 18 in. (457 mm) horizontally and vertically.
- (c) Provide additional anchors around openings larger than 16 in. (406 mm) in either direction. Space anchors around perimeter of opening at a maximum of 24 in. (610 mm) on center. Place anchors within 12 in. (305 mm) of openings.

3. TMS Section 12.2.2.10.1.2:

For Seismic Design Category C and above, isolate the sides and top of anchored veneer from the structure so that vertical and lateral seismic forces resisted by the structure are not imparted to the veneer.

4. TMS Section 12.2.2.10.2.2:

For Seismic Design Category D and above.

- (a) Reduce the maximum wall area supported by each anchor to 75 percent of that required in Sections 12.2.2.5.6.1 and 12.2.2.5.6.2. Maximum horizontal and vertical spacings are unchanged.

5. TMS Section 12.2.2.10.3.2:

For Seismic Design Category E and F, support the weight of anchored veneer for each story independent of other stories.

6. TMS Section 12.2.2.5.7:

Joint thickness for anchors - Mortar bed joint thickness shall be at least twice the thickness of the embedded anchor.

The primary limitation from TMS 402's prescriptive method related to anchored veneers that this manual addresses is:

The maximum cavity size from the inside face of the veneer to the face of the backup (masonry, wood studs or cold-formed metal framing) shall be 4 ½ inches. This includes a 1-inch minimum air space.

This limitation is likely a result of the types of anchors that have been standard in the industry and the small cavities that were common. With increasing cavities, some manufacturers are providing the ties and anchors that accommodate the conditions we see in modern buildings.

Concrete Products Group Design Solution Tie and Anchor Selection

As an aid to architects and engineers, Concrete Products Group has produced this recommended “Design Solution”. In the development of this improved veneer solution, this specific product offers enhanced performance over traditional veneer systems. The products referenced are available from multiple suppliers and should not be considered as a proprietary system.

CPG recommends ties and anchors manufactured by the FERRO Corporation (www.ferrocorp.com), specifically for wide cavities. These ties and anchors by FERRO provide equal or higher strength capacity to the wire anchors, sheet metal anchors or joint reinforcement anchors that are acceptable by TMS 402 for 4 1/2-inch cavities.

An added benefit to the FERRO system is that the anchors provide reduced thermal characteristics by restricting heat transfer from the veneer to the back up. Tests by RDH Building Engineering Ltd. For FERRO Corporation showed that FERRO ties and the shelf angle supports can significantly reduce the impact of thermal bridging and maximize the effective R-value of walls with exterior continuous insulation.

Figure 2 shows a conventional V-tie for the veneer and a metal plate anchor into the CMU. Figure 3 shows the same conventional V-tie into the veneer and another steel plate anchor attached to the web of the cold formed metal framing (CFMF) stud. Both anchors are slotted for vertical adjustment and movement.

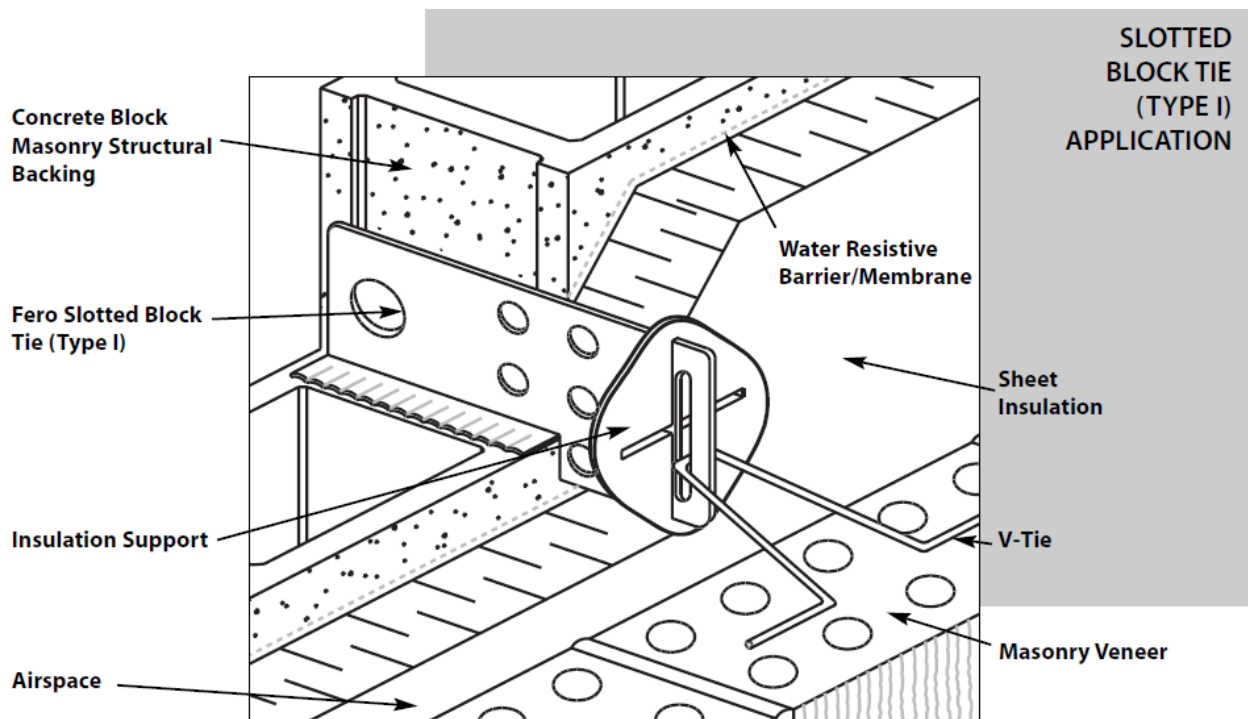

Figure 2 – Anchor to CMU

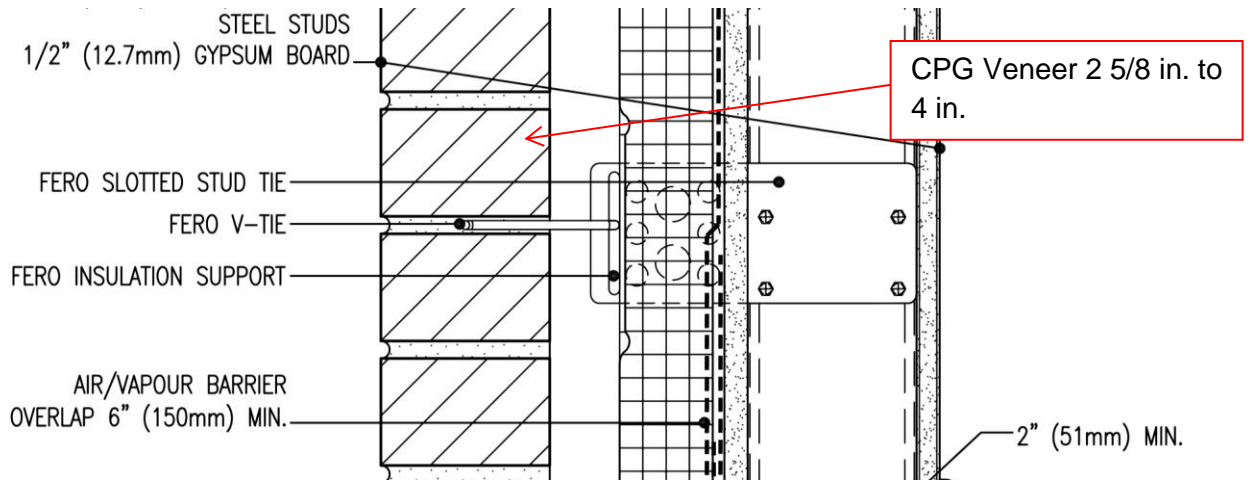

Figure 3 - Anchor to Cold formed metal studs

The FERRO V-ties are 3/16 inch diameter (0.19 in.). TMS Section 12.2.2.5.6.1 requires the wire size be at least 0.148 inches in diameter for adjustable anchors. So, FERRO ties provide extra capacity for both tension and compression.

Due to the steel plates used by FERRO for its anchors, the anchors are suited to cavity widths of any size. The designer need only specify the required cavity size. The manufacturer provides the following plate thicknesses (Table 1) dependent upon the cavity size. While 16 gauge plates have been tested as more than adequate for tension loads, the gauges used are actually intended to provide sufficient capacity for compression.

Table 1 - Anchor Plate Thickness	
Cavity width (inches)	Plate thickness (gauge)
0 to 4.5	16
4.5 to 9.5	14

Tie and Anchor Spacings

The prescriptive method of TMS 402 sets spacing requirements for various anchor types. In Table 2 below, the criteria for two-piece adjustable anchors with anchored veneer laid in running bond will be used.

Note: In the Table 2, the velocity, q_z from ASCE 7-10 was used per TMS 402.

Table 2 - Wall Tie and Anchor Spacing			
Loading condition	Area per anchor (ft²)	TMS Reference	Maximum spacing – horizontally (in.) x vertically (in.)
q _z (velocity pressure) less than 40 psf; no height limit	2.67	Section 12.2.2.5.6.1	32 x 25
q _z (velocity pressure) of 40 psf to 55 psf; height limited to 60 ft	1.87	Section 12.2.2.11	18 x 18
q _z (velocity wind pressure) over 55 psf	Not permitted		
Seismic Design Category C and below	2.67	Section 12.2.2.10.1	32 x 25
Seismic Design Category D, E and F	2.00	Section 12.2.2.10.2.2	32 x 25

Notes:

1. If the veneer is not laid in running bond, all maximum spacings listed should be reduced to 18 inches horizontally and vertically. This criterion is listed in TMS Section 12.2.2.9 for veneer backed by masonry or concrete, but would be appropriate for CFMF as well.
2. The designer may be able to exceed the tabulated area per anchor and spacings by using the Special Systems of Design process of Section 1.3, TMS 402 or the Alternate Design criteria of Section 12.2.1, TMS 402.

Construction Note

The installation of CPG veneers with anchors is to be in accordance with industry tolerances and standards (TMS 602, *SPECIFICATION FOR MASONRY STRUCTURES*).

Anchoring to veneer units requires the ties are properly embedded in the mortar joints. Some CPG veneer units have cores similar to those found in clay brick veneer units. Therefore, TMS 602, Article 12.2.2.5.2 requires:

12.2.2.5.3. Wire anchors shall be placed as follows:

- (a) *With solid units, embed anchors in the mortar joint and extend into the veneer a minimum of 1-1/2 in. (38.1 mm), with at least 5/8-in. (15.9-mm) mortar cover to the outside face.*
- (b) *With hollow units, embed anchors in mortar or grout and extend into the veneer a minimum of 1-1/2 in. (38.1 mm), with at least 5/8-in. (15.9-mm) mortar or grout cover to the outside face.*

Project specifications should require cores of units be filled solid at anchor locations.

Veneer Calculator

To simplify the determination of the anchor spacings, CPG has an on-line calculator for designers to use. The calculator is available in the Design Resource Center on the CPG web site (<http://www.concreteproductsgroup.com/>).

Since the code is silent on the maximum building height for which prescriptive criteria should be used, CPG has selected a maximum building height of 160 ft for $q_z < 40$ psf. The engineer user may decide whether to exceed this height.

When $40 \text{ psf} < q_z < 55 \text{ psf}$, the maximum building height is 60 ft per TMS 402. Taller buildings will require additional calculations per ASCE 7.

For the calculator, the user needs to input project specific information including:

Wind:

1. Wind velocity: This data is determined from ASCE 7 for the project site.
2. Wind Exposure Category per ASCE 7.
3. Building height and length.
4. Floor or roof elevation just above the wall being considered.

Seismic:

1. Masonry weight (psf of wall area).
2. Seismic Design Category.

The calculator provides the velocity pressure and the required area per anchor for both wind and seismic conditions. The velocity pressure is obtained from ASCE 7.

$$q_z = 0.00256 K_z K_{zt} K_d V^2$$

K_z is velocity pressure exposure coefficient defined in Section 30.3.1. It adjusts the height and wind exposure

K_{zt} is the topographic factor defined in Section 26.8.

$K_{zt} = (1 + K_1 K_2 K_3)^2$. This manual assumes $K_{zt} = 1.0$. The user should verify their site meets this condition. If the site has escarpments, ridges or hills close by, the value may have to be modified.

K_d is the wind directionality factor = 0.85 for buildings from Table 26.6-1.

V is the basic wind speed from Section 26.5 that must be selected based upon the location and Risk Category for the project.

After that, the designer can input either the preferred vertical or horizontal spacing of the anchors and the calculator will provide the corresponding maximum horizontal or vertical spacing respectively. The anchor spacings apply to both Zone 4 and Zone 5 of the walls.

When using the FERO anchors in a CMU backup, the anchors should be in the head joints of the backup. So unless there are half or cut units in specific locations, the preferred horizontal spacing is 16 inches.

In the following examples, the topographical conditions produce $K_{zt} = 1.0$.

Example 1:

Wind velocity = 110 mph
 Wind Exposure Category: C (Note: This cell has a Dropdown menu.)
 Building height = 160 ft Building length = 115 ft
 Height of building at anchors = 60 ft
 Seismic Design Category: D Veneer weight: 40 psf
 The following screen shot shows the calculator results.

The calculator determines the maximum horizontal and vertical anchor spacings. Then the User can input possible combinations and the calculator indicates when the combination meets the acceptable limits (yellow cells).



Project: Example
 Date: 4/19/2016
 Engineer: dtb

Masonry Wall Anchor Calculator

Codes: ASCE 7-10 TMS 402-13

WIND INFORMATION

Basic Wind Speed: 110 mph
 Wind Exposure Category: C

SEISMIC INFORMATION

Seismic Design Category: >D

BUILDING INFORMATION

Wall length, L: 60 feet
 End zone, a: 6 feet
 height of building, h: 160 feet
 Veneer weight, W_p : 40 psf

Anchor Information

For gable ends, use maximum h of wall.

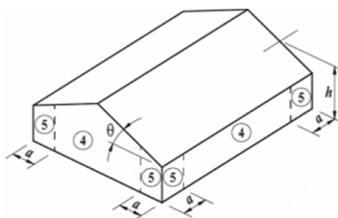

For multi-story walls, use maximum h of of the story under consideration.

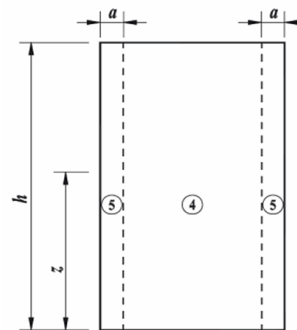

WALL ELEVATION

z = Elevation of wall anchors (feet)	Velocity Pressure (psf) q_z (Strength)	Maximum area per anchor (sf)		Maximum Horizontal Spacing (in.)	Maximum Vertical Spacing (in.)	User Horizontal Spacing (in)	User Vertical Spacing (in)	Actual Horizontal Spacing (in)	Actual vertical Spacing (in)
		Wind	Seismic						
160	36.8	2.67	2	32	25	16	16	16	16

Figure 4 – Example 1 CPG Calculator

Example 2:

Wind velocity = 135 mph
 Building height = 55 ft
 Height of building at anchors = 50 ft
 Seismic Design Category: C

Wind Exposure Category: B
 Building length = 80 ft
 Veneer weight: 38 psf

The following screen shot shows the calculator results.



Project: Example 2
 Date: 4/27/2016
 Engineer: dtb

Masonry Wall Anchor Calculator
 Codes: ASCE 7-10 TMS 402-13

WIND INFORMATION
 Basic Wind Speed: 135 mph
 Wind Exposure Category: B

SEISMIC INFORMATION
 Seismic Design Category: C

BUILDING INFORMATION
 Wall length, L: 80 feet
 End zone, a: 8 feet
 height of building, h: 55 feet
 Veneer weight, W_v : 38 psf

Anchor Information

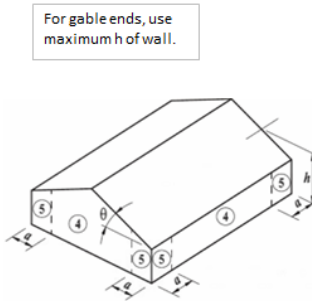

For multi-story walls, use maximum h of the story under consideration.

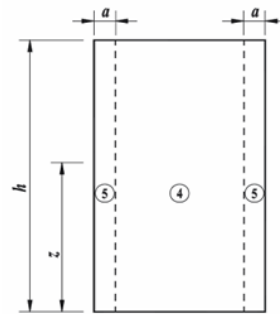

z = Elevation of wall anchors (feet)	Velocity Pressure (psf) q_z (Strength)	Maximum area per anchor (sf)		Maximum Horizontal Spacing (in.)	Maximum Vertical Spacing (in.)	User Horizontal Spacing (in)	User Vertical Spacing (in)	Actual Horizontal Spacing (in)	Actual vertical Spacing (in)
		Wind	Seismic						
50	32.1	2.67	2.67	32	25	16	24	16	24

Figure 5 – Example 2 CPG Calculator

Shelf Angle Supports

FERO Corporation also provides a bracket system (FAST) to support shelf angles. While the brackets allow the use of large cavities, they were also developed to restrict heat transfer into the support floor or wall. Technical reports are available at the FERO web site (http://www.ferocorp.com/technical_notes/FERO_Thermal_Analysis.pdf).

The brackets are intended to be supported by concrete slabs or beams. Brackets can also be bolted to reinforced and grouted masonry, but no guidance is provided here. The engineer must make their own design choices. Extended brackets can be welded to steel framing.

Figure 3 shows the bracket and angle at a floor level. Figure 6 shows a special bracket and angle that would be used above an opening. Figure 7 shows two examples of an extended bracket; the extended bracket can also be welded to a perimeter steel beam. Figure 7(b) can also be used over openings. The insulation is shaded in yellow. The cavity includes the insulation and the mandatory air space (2 inches recommended, 1 inch minimum).

Figure 8 shows a bracket and angle at a foundation. There is an inverted version of this detail available also. Note: Continuous rigid insulation is shown on this detail to illustrate that the support can accommodate insulation. It is not intended to imply that continuous insulation is required. Unlike for steel framed walls, ASHRAE 90.1 does not mandate continuous insulation for load bearing masonry buildings. The designer of masonry buildings may demonstrate compliance without continuous insulation based on the building envelope as a whole, rather than on the prescriptive component-by-component basis.

All these details can be mixed and matched as needed.

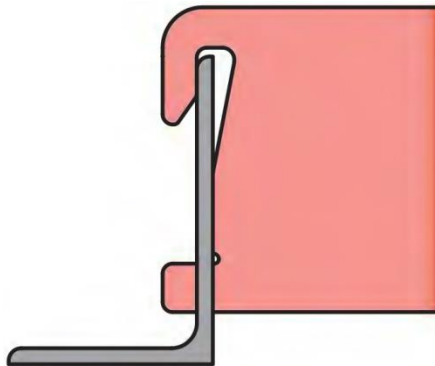

Figure 6 – Bracket for use over and opening.

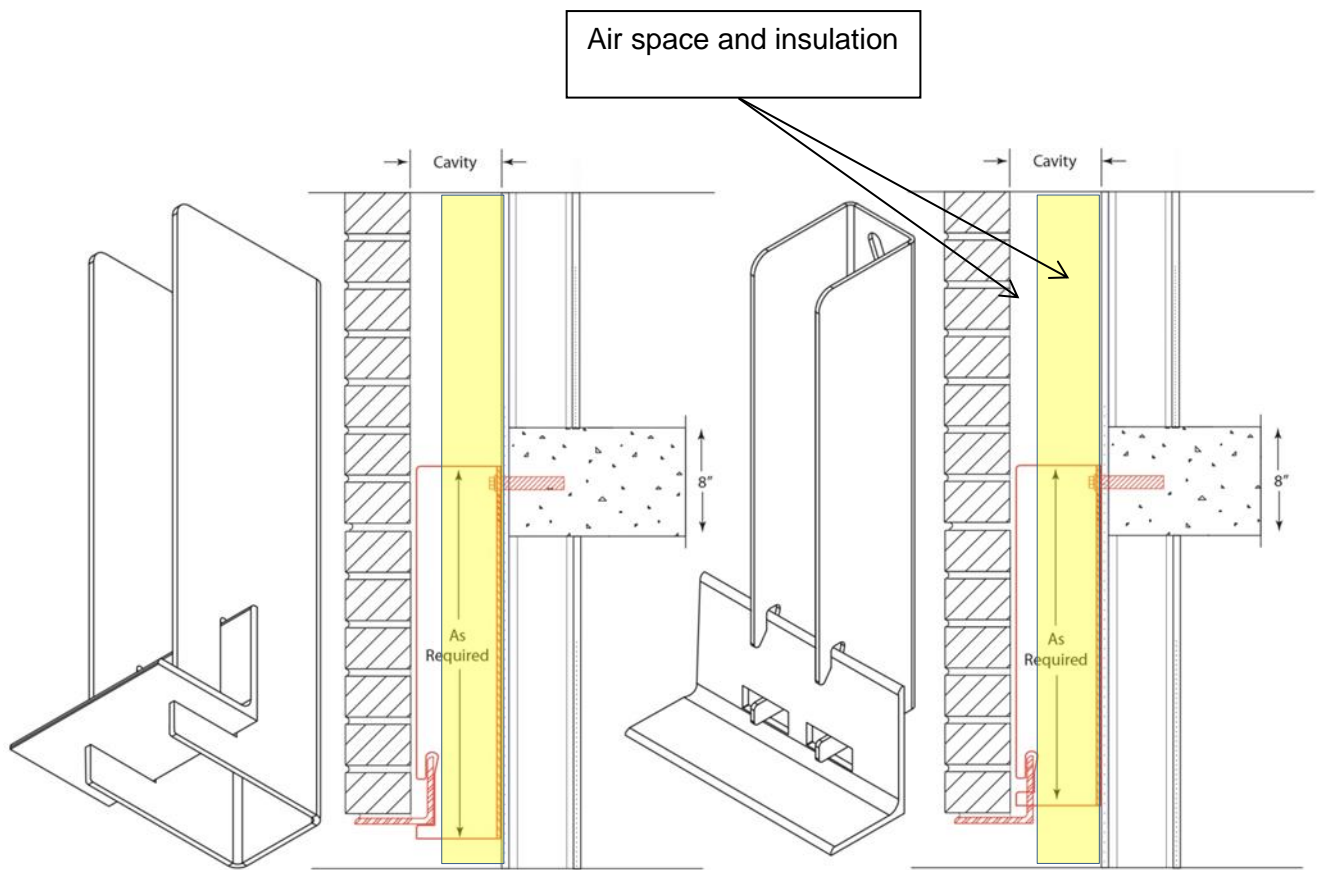

Figure 7 – Extended bracket (a) and (b)

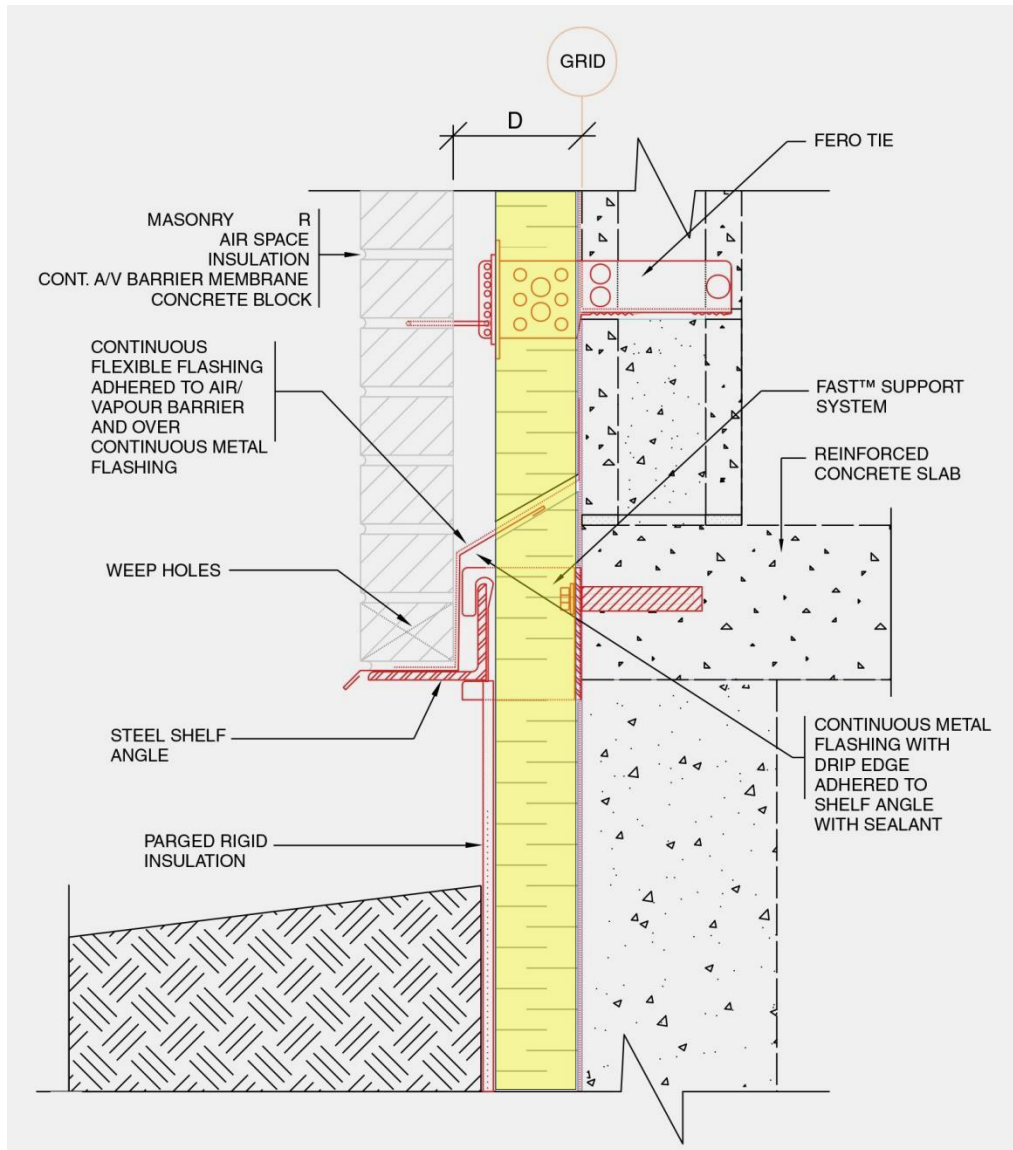

Figure 8 – Foundation Detail

The FEROTIE technical data (FAST™ SYSTEM, Fero Angle Support Technology, *TECHNICAL REPORT* prepared by Yasser Korany, Ph.D., P.Eng., Mohammed Nazief, August 2013) provides bracket sizes and bracket spacing for various cavities up to 6.5 inches (165mm). These tables must be extended for larger cavities using Figure 9. Note: The detail shows the cavity and not specifically the insulation and air space.

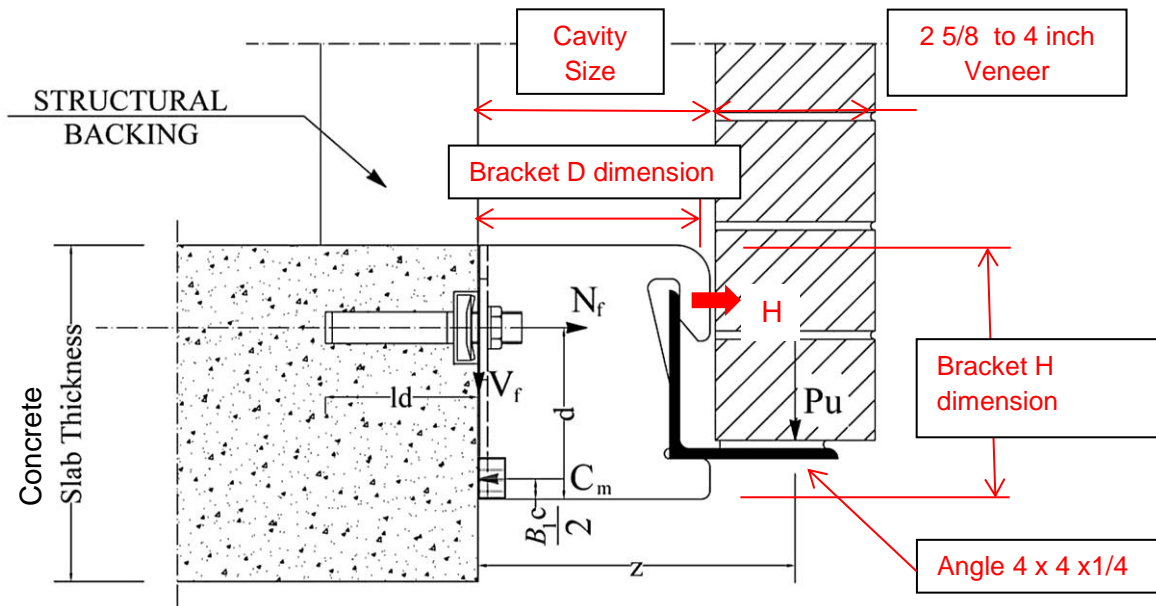

Figure 9 – Bracket and anchor bolt loading

FERO data indicates that one of the controlling parameters for the bracket is the top “claw” of the bracket (see H in Figure 9); each bracket has two “claws”. Using unfactored loads, the maximum horizontal load that each “claw” can support is 690 lb. Therefore, the maximum unfactored load the bracket can support at H is 1,380 lbs.

The second controlling parameter is the bolt itself and the concrete structure. Table 3 provides factored loads that the engineer may use to size the bolts. Brackets are fabricated for 5/8 inch diameter anchor bolts. Larger anchor bolts, require a special order bracket.

While Figure 9 shows the bracket attached to a concrete slab, the brackets may be fastened to grouted CMU provided the designer calculates the capacity of the CMU to support the Anchor Bolt Loading per bracket (N_f and V_f) listed in the Table.

Table 3 – Shelf Angle Support

Cavity Size (inches)	FAST Bracket Size (See Figure 9) (25.4mm = 1 inch)		P = Maximum Unfactored Load per bracket (lb). (For P_u and V_f , multiply by 1.4.)	Maximum Allowable Veneer Height*(ft)			Anchor Bolt Loading per bracket	
	D (mm)	H (mm)		Bracket Spacing			N_f = Factored Axial (lb)	V_f = Factored Shear (lb)
				16 in.	24 in.	36 in.		
1	25	188	1,500	20.0^	17.9	11.9	1,128	2,108
1.5	38	160	1,400	20.0^	16.7	11.1	1,841	1,952
2	51	160	2,100	20.0^	20.0^	16.7	3,156	2,927
2.5	64	160	2,100	20.0^	20.0^	16.7	3,550	2,927
3	76	160	2,100	20.0^	20.0^	16.7	3,945	2,927
3.5	89	160	2,100	20.0^	20.0^	16.7	4,340	2,927
4	102	160	1,925	20.0^	20.0^	15.3	4,376	2,706
4.5	114	160	1,750	20.0^	20.0^	13.9	4,302	2,456
5	127	160	1,575	20.0^	18.8	12.5	4,158	2,204
5.5	140	160	1,400	20.0^	16.7	11.1	3,945	1,943
6	152	160	1,250	20.0^	14.9	9.9	3,800	1,763
6.5	165	160	1,100	19.6	13.1	8.7	3,535	1,543
7	178	160	1,020	18.2	12.1	8.1	3,475	1,432
7.5	191	160	950	17.0	11.3	7.4	3,423	1,337
8	203	160	895	16.0	10.7	7.1	3,377	1,253
8.5	216	160	840	15.0	10.0	6.7	3,340	1,180
9	229	160	800	14.3	9.5	6.3	3,304	1,144

Notes:

- *Assumed veneer weight, $w = 42$ psf. Use a factor of 1.4 for ultimate loads.
Maximum allowable veneer height = $P / (w \times \text{bracket spacing})$.
- W (width of each bracket) = 95 mm.
- Brackets are fabricated for 5/8 inch diameter anchor bolts. Larger anchor bolts, require a special order bracket.
Table assumes the anchor bolts are placed in the center of the slotted holes ($d = 3.9$ in. for $H=160$ mm in Figure 9).
- Based upon FERO test data, Table assumes a minimum concrete strength for bracket support, $f'_c = 5,000$ psi. Reduce the values for Maximum Unfactored Load per bracket, Maximum Allowable Veneer Height, and Anchor Bolt Loading per bracket for lower concrete strengths.
Reduce tabulated values to 83% for $f'_c = 4,000$ psi
Reduce tabulated values to 62% for $f'_c = 3,000$ psi
- ^ denotes maximum recommended height of veneer = 20 ft. Consult FERO for larger values.
- Reduce Anchor Bolt Loadings in proportion to the actual veneer height to the maximum allowable veneer height in the table for a given bracket spacing.

Acknowledgements

The author acknowledges Mr. William Dawson, CPG Executive Director, and Mr. Canan D'Avela, CPG Technical Director, for their assistance in developing this Manual. Special thanks go to Dr. Michael Hatzinikolas PhD, the inventor of the FERRO anchors and President of the FERRO Corporation for his technical assistance. The Veneer Calculator was developed with the assistance of Tyler Witthuhn, EIT.

Nationwide Availability

The Concrete Products Group LLC (CPG) consists of regional market leaders in the concrete products industry. The CPG is organized to provide consistent, top-quality products to regional and national customers.

800-789-0872

A-1 BLOCK
1617 South
Division Avenue
Orlando, FL 32805

A. JANDRIS & SONS
202 High St.
Gardner, MA
01440

**AMCON CONCRETE
PRODUCTS, LLC**
2025 Centre Pointe Blvd.,
Suite 300
Mendota Heights, MN
55120-1221

BARNES & CONE
P.O. Box 280
5894 Court St. Rd.
Syracuse, NY
13206-0280

**BASALITE CONCRETE
PRODUCTS LLC**
605 Industrial Way
Dixon, CA
95620

**DAGOSTINO BUILDING
BLOCKS, INC.**
1111 Altamont Avenue
Schenectady, NY 12303

**FENDT BUILDERS
SUPPLY**
22005 Gill Rd,
Farmington, MI
48335

**FIZZANO BROTHERS
CONCRETE
PRODUCTS, INC.**
1776 Chester Pike
Crum Lynne, PA
19022-1299

BEST BLOCK
7620 Washington
Ave.
Houston, TX
77007

**JOHNSON
CONCRETE
COMPANY**
217 Klumac Road
Salisbury, NC 28144

**MIDWEST
PRODUCTS GROUP**
12901 St. Charles Rock
Rd.
Bridgeton, MO
63044-2485

OBERFIELDS, LLC
P.O. Box 362
528 London Rd.
Delaware, OH 43015

**ORCO BLOCK &
HARDSCAPE**
11100 Beach Blvd.
Stanton, CA
90680-0129

**WESTERN
MATERIALS
COMPANY**
1202 South First Street
Yakima, WA 98901

Manufacturing Locations

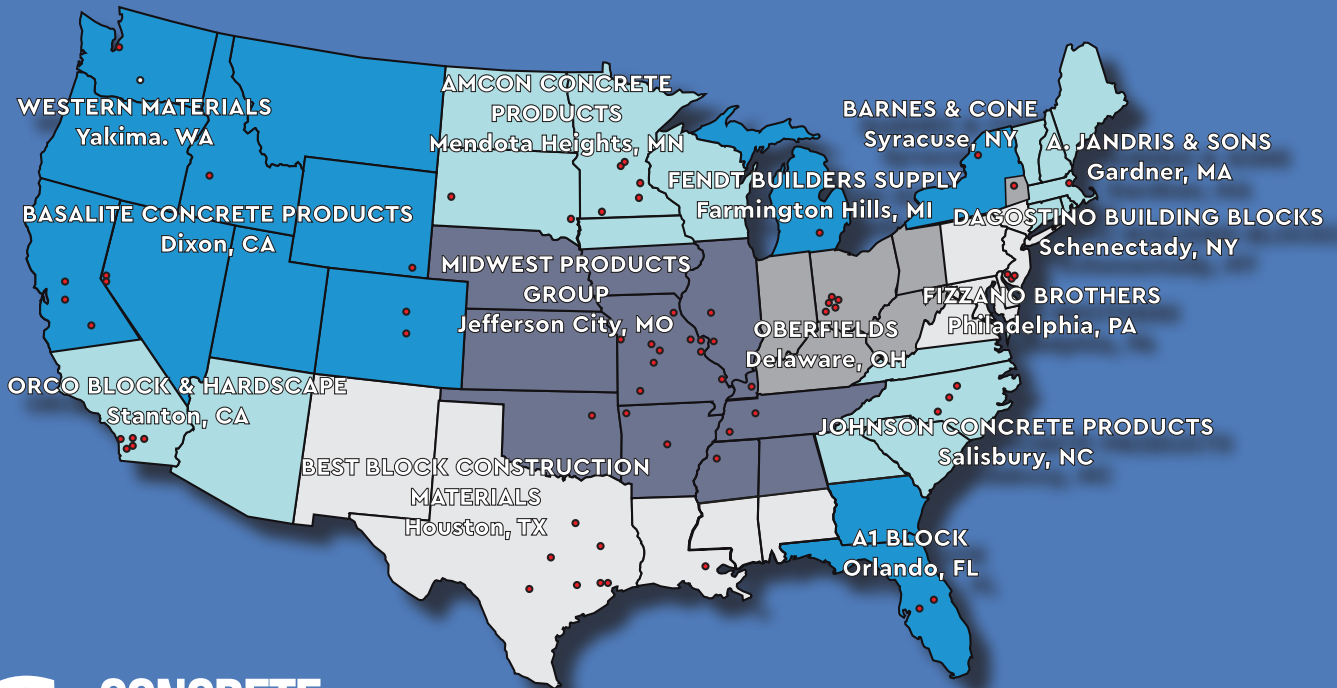

INNOVATIVE CONCRETE
MASONRY SYSTEMS

www.concreteproductsgroup.com

©2020 Concrete Products Group, LLC
All rights reserved. RD 01082010